

Shuttlelift CD3300 Series

Product Guide



Features

- CD3330F: 7,7 t (8.5 USt) three-section boom with 7,6 m (25 ft 2 in) tip height
- CD3330FL: 7,7 t (8.5 USt) three-section boom with 10,2 m (33 ft 6 in) tip height
- CD3339: 8,1 t (9 USt) three-section boom with 11,6 m (38 ft 2 in) tip height
- CD3340B: 9,5 t (10.5 USt) three-section boom with 11,6 m (38 ft 2 in) tip height
- 1,8 m (6 ft) fixed extension (CD3330F/ CD3330FL) and 3,6 m (12 ft) offsettable swingaway extension (CD3339 and CD3340B)
- 63,4 kW (85 bhp) Cummins diesel engine or 59,6 kW (80 bhp) GM EFI dual fuel engine



Features



Boom

Standard:

6,4 m (21 ft) main boom on the CD3330F.
9,1 m (30 ft) main boom on the CD3330FL.
10,0 m (32 ft 10 in) main boom on the CD3339 and CD3340B.

Optional: Manual fourth main boom section adds 3,0 m (10 ft) additional main boom length on CD3340F and CD3330FL only.



Pivoting boom nose

Standard on the CD3339 and CD3340B the exclusive pivoting boom nose allows operators to decrease the overall boom head depth and operate in more confined areas.



Steering

Standard: four-wheel coordinated steer

Standard: two-wheel, four-wheel, and crab steer with self alignment (CD3340B)

Optional: two-wheel, four-wheel, and crab steer (standard on CD3339)



Cab

Standard: Open air cab shell with overhead safety glass

Optional: Closed cab with hinged door, heater/defroster, and all window glass



Engine

Standard: Cummins QSB 3.3 L turbo-charged diesel rated at 63,4 kW (85 bhp) at 2600 rpm.

Contents

Specifications	4
CD3330F (dimensions/range diagram/load chart)	7
CD3330FL (dimensions/range diagram/load chart)	10
CD3339 (dimensions/range diagram/load chart)	15
CD3340B (dimensions/range diagram/load chart)	18
Symbols glossary	21

Specifications

Superstructure

Boom

CD3330F: 2,9 m – 6,5 m (9 ft 8 in – 21 ft 2 in) three-section full power boom.
Maximum tip height: 7,6 m (25 ft 2 in)

CD3330FL: 3,8 m – 9,2 m (12 ft 8 in – 30 ft 2 in) three-section full power boom.
Maximum tip height: 10,2 m (33 ft 6 in)

CD3339 and CD3340B: 4,2 m – 10,0 m (13 ft 10 in – 32 ft 10 in) three-section full power boom.
Maximum tip height: 11,6 m (38 ft 2 in)

*Optional boom

CD3330F and CD3330FL: Manual fourth main boom fly section adds 3,0 m (10 ft) additional boom length.

*Boom extension

CD3330F and CD3330FL: 1,8 m (6 ft) fixed pin on extension

CD3339 and CD3340B: 3,6 m (12 ft) offsettable extension. 3,6 m - 5,4 m (12 ft - 18 ft) telescopic offsettable extension

Boom nose

CD3330F and CD3330FL: Single sheave non-pivoting

CD3339 and CD3340B: Single sheave, three-position (0°, + 30°, + 80°) pivoting boom nose for minimizing head space requirements. Lowers head height. 0,26 m (10.5 in) when nose is pivoted fully forward.

Boom elevation

Single double acting hydraulic cylinder with integral holding valve.

Elevation: 0° to 60° for the **CD3330F and CD3330FL.**

0° to 72° for the **CD3339 and CD3340B**

Anti-two block device

Standard anti-two block device, when activated, provides an audible warning to the crane operator and disengages all crane functions whose movement can cause two-blocking.

Load indicator (LSI)

A simple, effective, and easy to use load indicating system used in conjunction with the anti-two block system to assist the operator in efficient operation of the unit within the limits of the load chart. The display panel displays the hook load and warns the operator when a preset load capacity is exceeded. The warning is by a flashing light on the display panel. In conjunction with the load display panel (receiver), there is a wireless transmitter and load sensing pin attached to the boom head that transmits the hook load to the display panel. **(wireless system)**

*Rated Capacity Limiter (RCL)

Similar to the Load Indicator, but stops the telescope out and boom lift down function when a load limit is exceeded. Uses a similar display panel with the addition of displaying boom angle and boom length read outs on the panel.

(wireless system)

*Load Moment Indicator (LMI)

Digital display of boom angle, boom length, boom radius, capacity, and allows for operator in-put to set the limits based on load chart. Displays color coded light bar and audible alarm with function cutout if load exceeds entered parameters.

(hardwired system)

Swing

Ball bearing swing circle with 360° continuous rotation. Hydraulic driven worm gear and pinion.
Maximum speed: 2.05 rpm

Hydraulic system

CD3330F and CD3330FL: (2) gear pumps

CD3339 and CD3340B: Variable displacement piston pump and piggyback gear pump.

Combined flow: 107,9 Lpm (28.5 gpm)

Maximum system operating pressure: 3600 psi

CD3330F and CD3330FL: Six section valve bank mounted in dash panel with direct mechanical linkage for low effort lever control.

Specifications

Superstructure continued

CD3339 and CD3340B: Six section valve bank chassis mounted; operated via dash mounted, pilot pressure hydraulic joysticks.

Return line filter with full flow by-pass protection and service indicator.

89 L (23.5 gal) hydraulic reservoir with sight level gauge and steel side plating to guard against side impact damage.

Hoist specifications

CD3330F and CD3330FL: Worm drive with counter-balance valving. Equal speed power up and down.

CD3339 and CD3340B: Piston motor drive with spring applied/hydraulic released brake.

Drum diameter:

CD3330F and CD3330FL: 0,24 m (9.69 in)

CD3339 and CD3340B: 0,27 m (10.63 in)

Maximum single line pull:

CD3330F and CD3330FL: 4854 kg (10,700 lb)

CD3339 and CD3340B: 6350 kg (14,000 lb)

Maximum single line speed:

CD3330F and CD3330FL: 26,8 m/min (88 fpm)

CD3339 and CD3340B: 36,6 m/min (120 fpm)

Maximum permissible single line pull:

CD3330F and CD3330FL: 3855 kg (8,500 lb)

(12,7mm [1/2 inch] Python Ultra XIPS)

CD3339 and CD3340B: 4536 kg (10,000 lb)

(14,0mm [9/16 inch] EEIPS)

Rope length :

CD3330F and CD3330FL:

(three-section boom): 29,6 m (97 ft)

(four-section boom): 39,6 m (130 ft)

CD3339 and CD3340B: 36,6 m (120 ft)

Carrier



Frame

High strength alloy steel constructed with integral outrigger housings; front and rear lifting, towing, and tie-down lugs. 42 ft² carrydeck size with 6350 kg (14,000 lb) carrying capacity (**CD3330F, CD3330FL and CD3339**) and 7711 kg (17,000 lb) carrying capacity (**CD3340B**). Deck coated with anti-skid treatment.



Outriggers

CD3330F, CD3330FL and CD3339: Front and rear oblique type beams at all four corners with integral holding valves. Outrigger pads form an integral part of the beam.

CD3340B: Hydraulic telescoping beam with oblique type jack provides extended and down and retracted and down lifting capacities. Integral holding valves on both beam and jack.

Padsize CD3300 Series:

18 cm x 20 cm (7.4 in x 7.8 in)

Maximum outrigger pad load:

CD3300F/FL/CD3339: 122 psi

CD3340B: 387 psi



Outrigger controls

CD3330F, CD3330FL and CD3339: Lever controls located on dash panel which operate the beams in pairs from side to side.

CD3340B: Two switch operation mounted on dash panel. One -three- position rocker switch to select all beams/jacks, left beams/jacks only, or right beams/jacks only. Separate -four- way toggle switch to activate beams out/in and jacks down/up. Level bubble indicator located inside operators compartment.

*Independent outrigger controls available as an option.



Standard engine (Tier III)

Cummins QSB 3.3 L turbo-charged diesel rated at 63,4 kW (85 bhp) at 2600 rpm. Supplied with 110 V engine block heater and air intake grid heater.



*Optional engine

G.M. 3.0 L EFI dual fuel (gasoline / L.P.) rated at 59,6 kW (80 bhp) at 2600 rpm.



Operators control station

Frame mounted, open air style control station with cab shell. Includes all crane functions, driving controls, and overhead safety glass. Other standard equipment include a durable weather resistant seat with seat belt, hourmeter, sight level bubble, and fire extinguisher. The dash panel includes engine oil pressure gauge, engine water temperature gauge, fuel gauge, transmission low oil and high temperature warning lights, low battery warning light, and brake system low pressure warning light. The LSI (load indicator) receiver is mounted to the top of the dash and provides warning for A2B and exceeded load capacity.

Specifications



*Operators control station enclosed

Includes the standard cab shell with the addition of front and rear glass and glass on the right side. Hinged full door with sliding glass.

Front windshield wiper and heater and defroster is included.



Fuel tank capacity

70 L (18.5 gallon) all steel construction with steel side plate to guard against side impact.



Electrical system

One 12V maintenance free battery, 820CCA at 0°. Jump start connections. 63 amp alternator.



Drive

4 x 2 – Front axle drive with planetary hubs and limited slip differential.



Steer

CD3330F and CD3330FL: two-wheel, four-wheel steer

CD3339: two-wheel, four-wheel with crab steer

CD3340B: two-wheel, four-wheel, and crab steer with electronic self alignment.

Outside turning radius:

CD3330F, CD3330FL, CD3339:

Two w/s: 4,47 m (14 ft 8 in)

Four w/s: 3,10 m (10 ft 2 in)

CD3340B:

Two w/s: 4,88 m (16 ft)

Four w/s: 3,17 m (10 ft 5 in)



Transmission

CD3330F, CD3330FL, CD3339: Synchromesh -four- speeds forward and reverse with stalk mounted forward/reverse selector.

CD3340B: Powershift -four- gears forward and four-gears in reverse. Stalk mounted shifter on left side of steering column.



Axles

Front: Carraro planetary drive/steer with internal multi-wet-disc brakes and limited slip differential.

Rear: Fabricated non-drive steer with disc brakes



Tires

10.00 x 15 16PR pneumatic



Brakes

Hydraulic actuated internal wet-disc service brakes acting on all four wheels. A dash mounted toggle switch activates the dry disc parking brake on the transmission output yoke with a dash warning light.



Suspension

Front: Rigid mounted to frame.

Rear: Rigid mounted to frame.



Lights

Recessed mounted, includes head, tail, rear work, stop, and turn signals.



Maximum speed

35,6 km/h (22 mph)



Gradeability (theoretical)

CD3330F, CD3330FL, CD3339: 57%....no load
31%.... 5443 kg (12,000 lb) load

CD3340B: 68%....no load
40%.... 9072 kg (20,000 lb) load

Gross vehicle weight (G.V.W.)

CD3330F: 6849 kg (15,100 lb)

CD3330FL: 7512 kg (16,560 lb)

CD3339: 7734 kg (17,050 lb)

CD3340B: 7947 kg (17,520 lb)

*All weights with enclosed cab

Miscellaneous standard equipment

Single sheave, "Quick Reeve" style hookblock.;

CD3330F and CD3330FL: 8,0 t (8.5 USt)

CD3339: 8,1 t (9USt)

CD3340B: 10 t (10.5 USt)

Back-up alarm

CD3330F

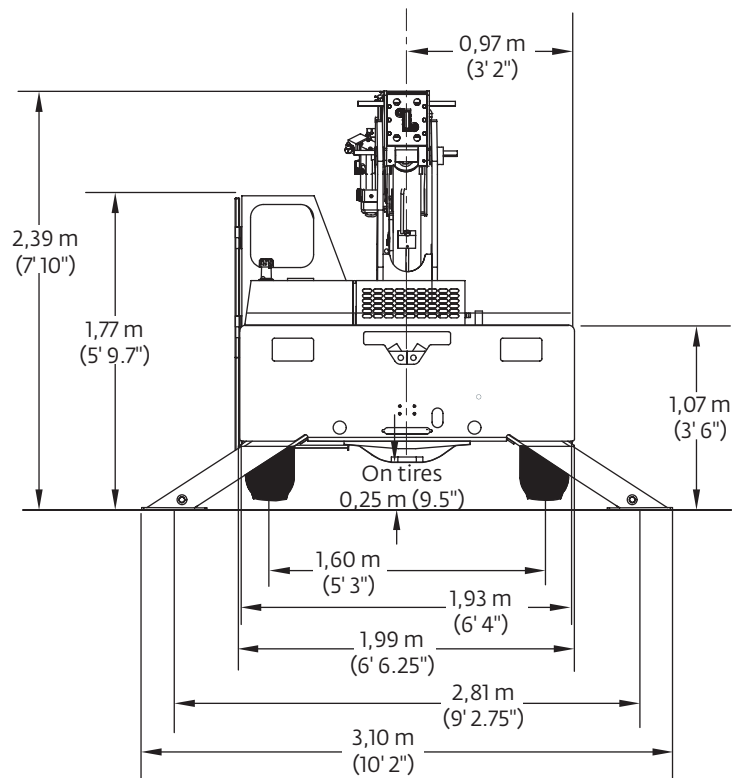
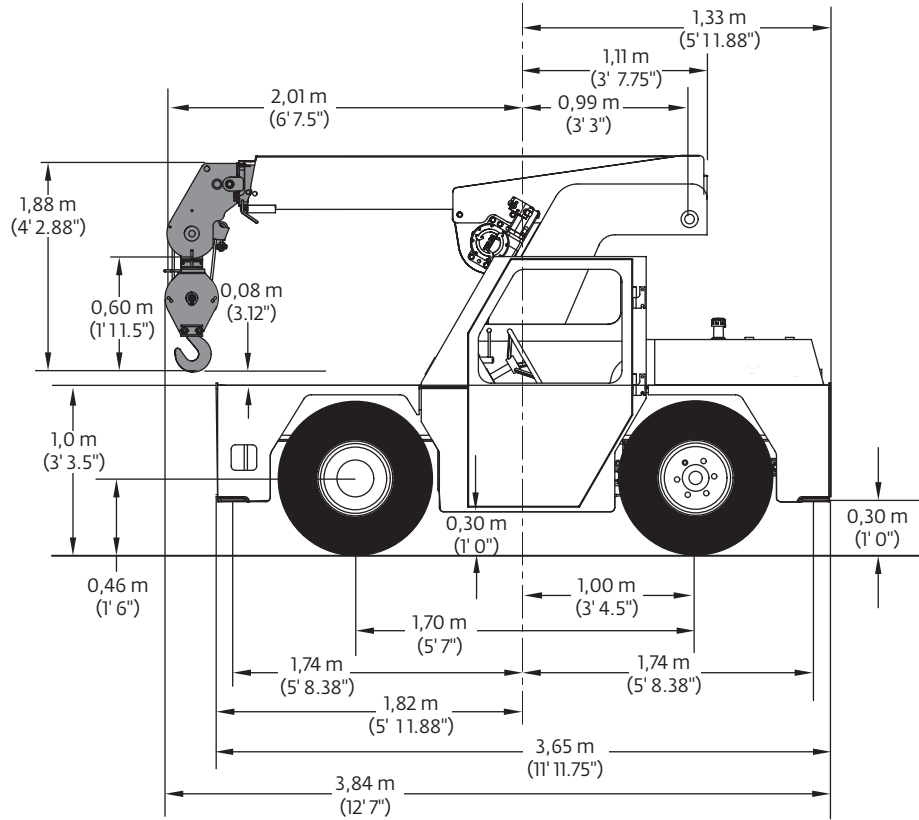

Range diagram

CD3330F

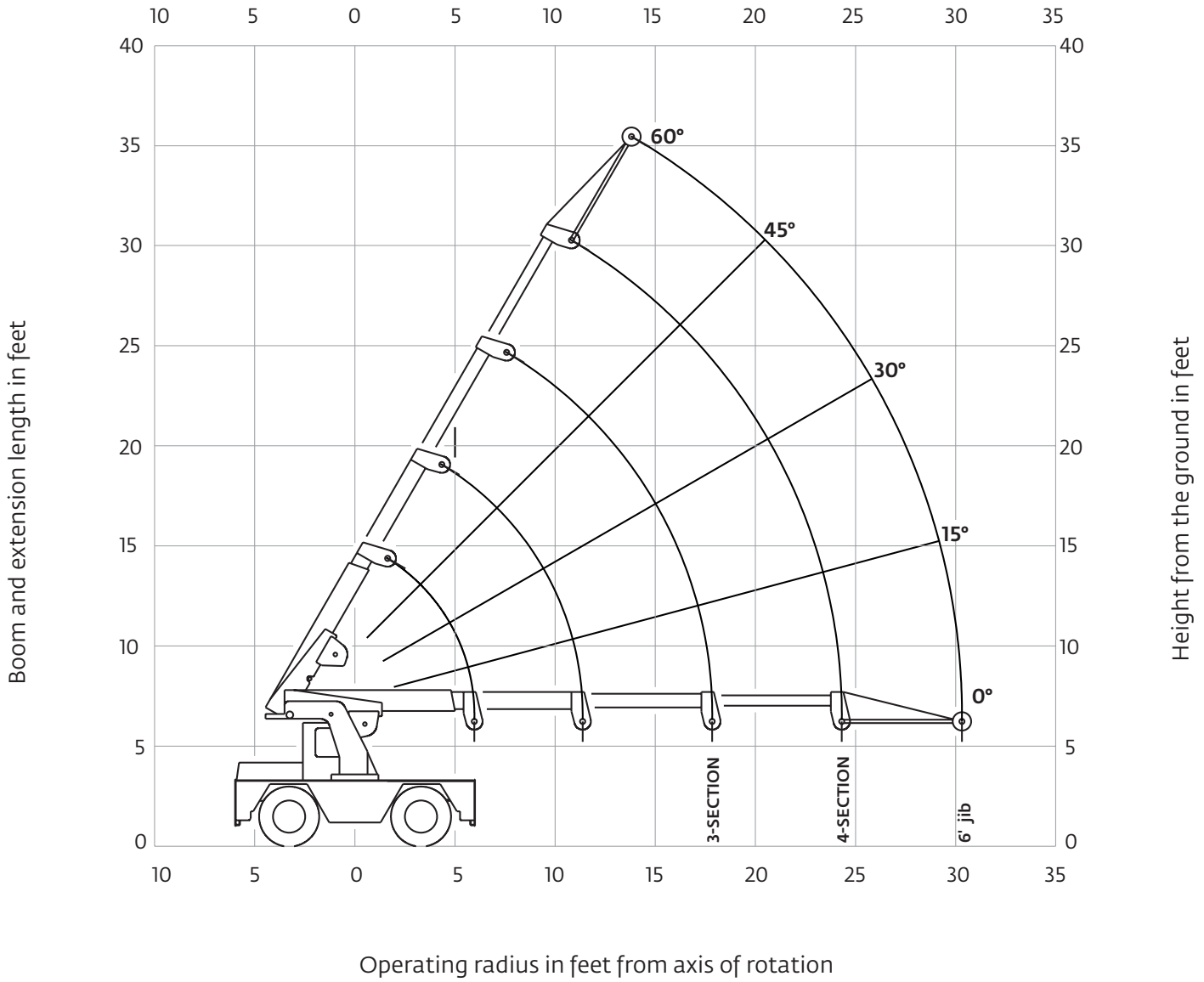

CD3330F

RADIUS (ft)	3-SECTION BOOM OR 4-SECTION BOOM WITH 4TH RETRACTED				RADIUS (ft)	4-SECTION BOOM WITH 4TH EXTENDED				MAIN BOOM ANGLE (deg)	JIB STRUCTURAL CAPACITIES (lb)		
	ON OUTRIGGERS (lb)		ON RUBBER (lb)			ON OUTRIGGERS (lb)		ON RUBBER (lb)			3-SECTION BOOM OR 4-SECTION BOOM WITH 4TH RETRACTED	4-SECTION BOOM WITH 4TH EXTENDED	
	F/R	360°	F/R	360°		F/R	360°	F/R	360°				
5.0	17,000	17,000	10,000	10,000	MAIN BOOM	5.0	6100	6100	6100	6100	60	3500	3500
6.0	15,700	14,400	10,000	7450		6.0	6100	6100	6100	6100	55	3325	3325
8.0	12,400	10,800	7150	4400		8.0	5300	5300	5300	5250	50	3150	3150
10.0	10,200	8600	4700	2950		10.0	4700	4700	4700	3750	45	3000	3000
12.0	8500	7000	3400	2175		12.0	4400	4400	3800	2450	40	2875	2875
14.0	7200	5400	2650	1700		14.0	4400	4400	2900	1875	35	2800	2800
16.0	6100	4300	2150	1325		16.0	4400	4400	2325	1525	30	2700	2700
18.0	5000	3550	1775	1100		18.0	4400	4100	1900	1225	25	2600	2600
20.0	2700	2700	1525	950		20.0	4300	3150	1600	1000	20	2500	2500
22.0	2600	2600	1350	825		22.0	3700	2700	1375	850	15	2400	2400
24.5	2200	2200	150	675		24.5	3100	2300	1200	700	10	2325	2325
26.0	-	-	-	-		26.0	2700	2125	100	650	5	2250	2250
28.0	-	-	-	-		28.0	2500	1900	975	575	0	2200	2200
30.0	-	-	-	-		30.0	2300	1700	850	475			
31.0	-	-	-	-		31.0	2200	1625	800	425			

* LIMIT RATINGS TO 11,800 LB WHEN 3RD SECTION IS EXTENDED ANY AMOUNT.

NOTES:

JIB CAPACITY IS LIMITED BY BOTH STRUCTURAL CAPACITY CHART AND MAIN CAPACITY CHART.

SHADED AREAS ARE GOVERNED BY STRUCTURAL STRENGTH, DO NOT RELY ON TIPPING.

OPERATION OF THIS EQUIPMENT IN EXCESS OF RATING CHARTS AND DISREGARD OF INSTRUCTIONS IS DANGEROUS AND VOIDS WARRANTY.

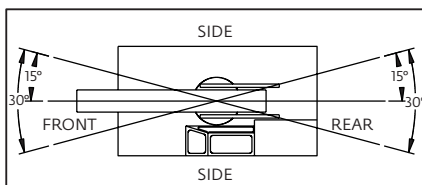

REDUCTION CHART		
	FROM MAIN BOOM RATINGS	FROM JIB RATINGS
MAIN BLOCK	140 lb	N/A
HOOK & BALL	100 lb	100 lb
JIB, STOWED	0 lb	N/A
JIB, DEPLOYED	150 lb	0 lb

RIGGING CHART	
1-PART 0-8500 lb	2-PART 0-17,000 lb
WIRE ROPE: 1/2 inch diameter Min. breaking strength 29,750 lb	

1) The rated loads are the maximum lift capacities as determined by operating radius, boom extension and boom angle. The operating radius is the horizontal distance from a projection of the axis of rotation to the supporting surface, before loading, to the center of vertical hoist line or tackle with load applied.

2) The rated loads shown on outriggers do not exceed 85% of actual tipping. The rated loads shown on rubber do not exceed 75% of actual tipping. These ratings are based on freely suspended loads with the crane leveled, standing on a firm, uniform supporting surface. Practical working loads depend on supporting surface, operating radius and other factors affecting stability. Hazardous surroundings, climatic conditions, experience of personnel and proper training must all be taken into account by the operator.

3) The weights of all load handling devices such as hooks, hookblocks, slings, etc., except the hoist rope, shall be considered part of the load. See reduction chart.

4) Ratings on outriggers are for either outriggers fully extended and down or fully retracted and down. Ratings for outriggers fully retracted and down will apply for any intermediate outrigger setting.

5) Ratings on rubber depend on tire capacity, condition of tires and proper inflation pressure (100 psi). Loads on rubber may be transported at a maximum speed of 2.5 mph on a smooth, hard, level surface with boom retracted to the shortest length possible and centered over front.

6) For operating radius not shown, use load rating of next larger radius.

7) The maximum combined total boom and deck load is 12,000 lb. The maximum deck load only is 14,000 lb.

8) Do not induce any external side loads to boom or jib.

1301286CD

Dimensions

CD3330FL

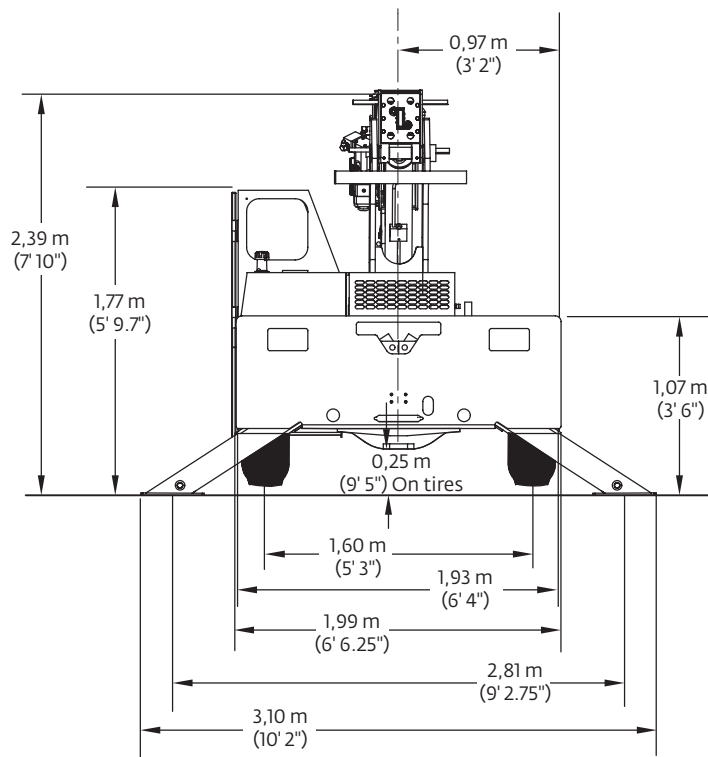
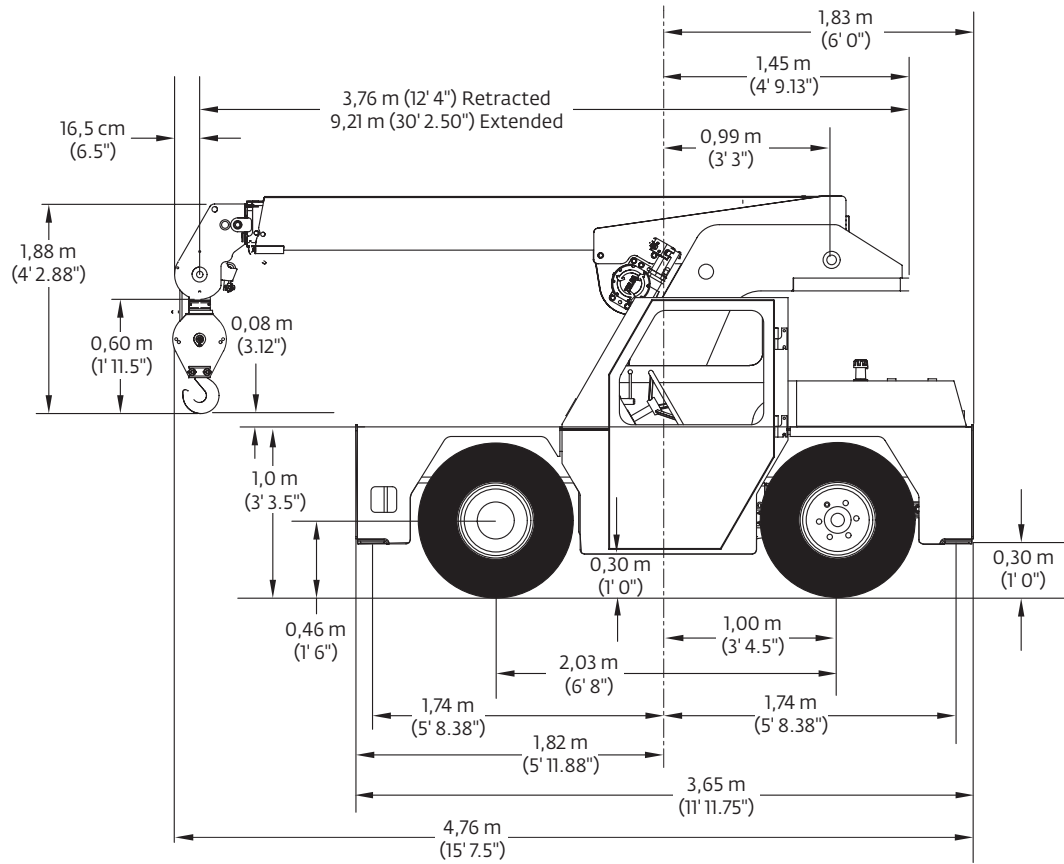

Range diagram

CD3330FL (Three-section boom)

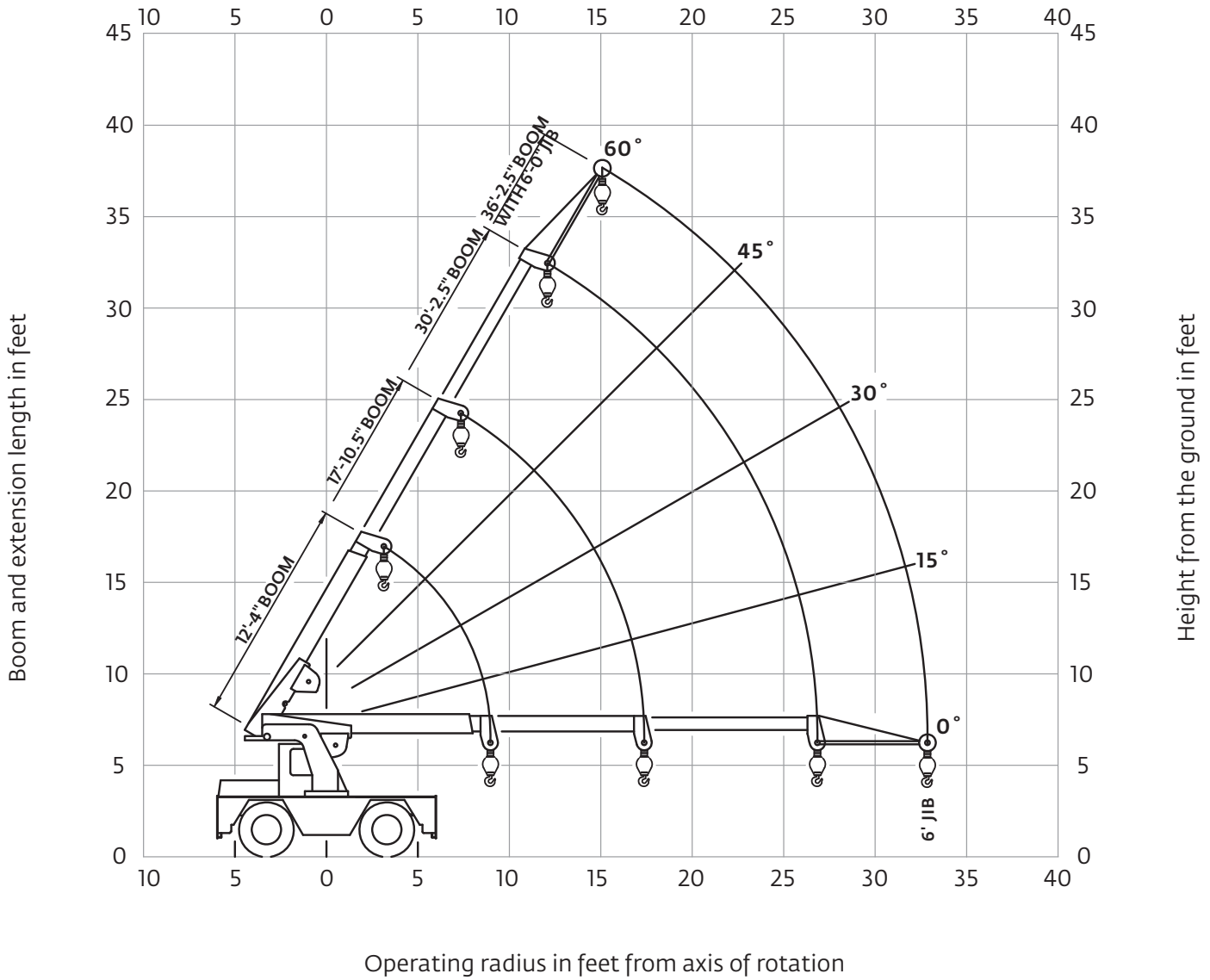

THIS CHART IS ONLY A GUIDE AND SHOULD NOT BE USED TO OPERATE THE CRANE.

Range diagram

CD3330FL (Four-section boom)

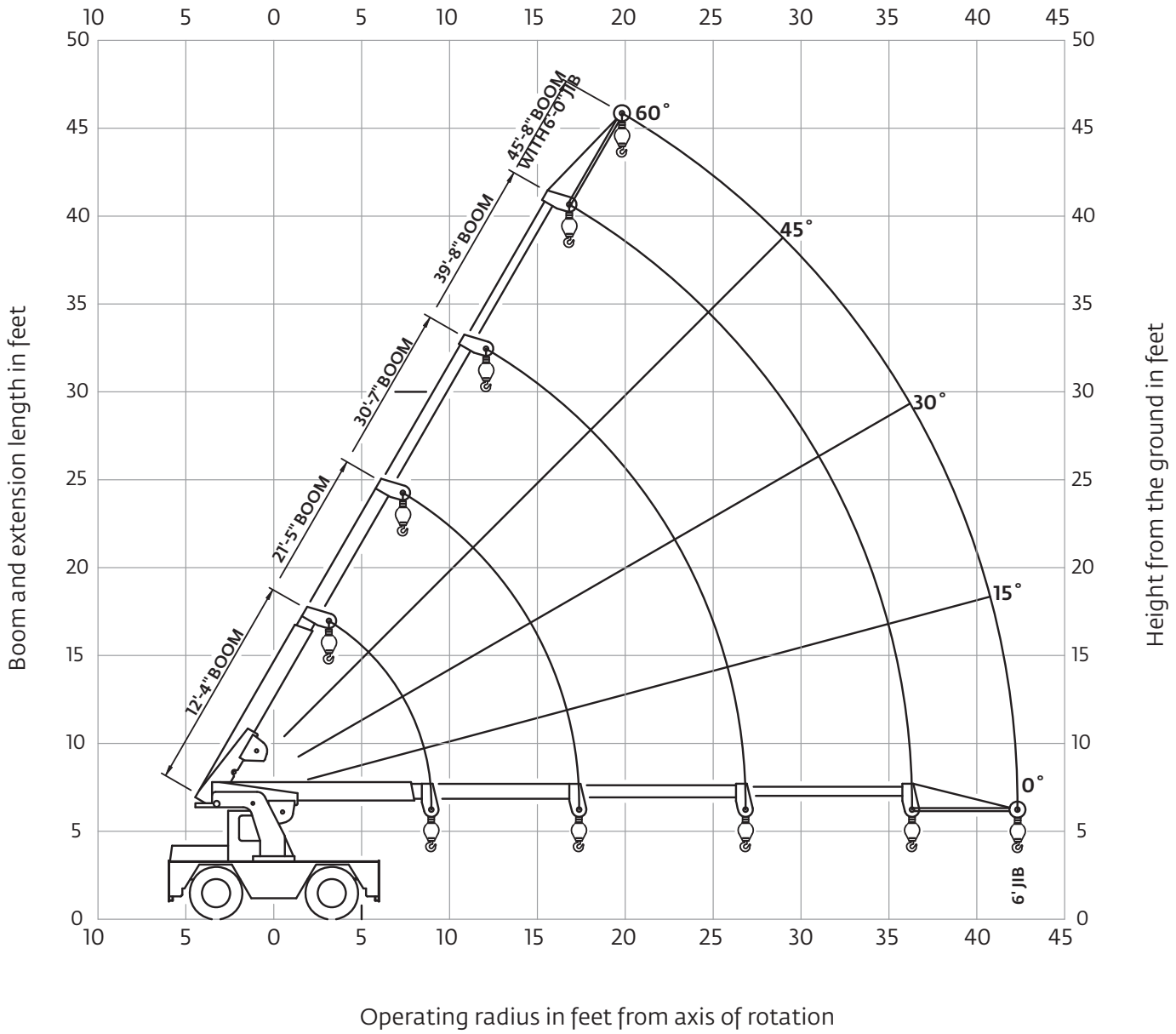

THIS CHART IS ONLY A GUIDE AND SHOULD NOT BE USED TO OPERATE THE CRANE.

The individual crane's load chart, operating instructions and other instructional plates must be read and understood prior to operating the crane.

CD3330FL (Three-section boom)

Radius (ft)	3-SECTION MAIN BOOM		Radius (ft)	3-SECTION MAIN BOOM		Radius (ft)	3-SECTION MAIN BOOM W/6 FT JIB DEPLOYED				
	ON OUTRIGGERS (lb)			ON RUBBER (lb)			LOADED BOOM ANGLE (deg)	ON OUTRIGGERS (lb)		ON RUBBER (lb)	
	F/R	360°		F/R	360°			F/R	360°	F/R	360°
5	17,000	17,000	5	10,000	10,000	16.4	60	3500	3500	2000	1300
6	15,700	14,400	6	9500	8200	18	57.5	3375	3375	1775	1150
8	12,400	10,800	8	7325	5125	20	53.5	3225	3150	1450	950
10	10,200	8500	10	4875	3475	22	49	3075	2700	1225	800
12	8500	6950	12	3550	2550	24	44.5	2950	2350	1025	650
14	7100	5800	14	2750	1925	26	39.5	2850	2050	875	525
16	6000	4650	16	2150	1450	28	34	2625	1825	800	425
18	5200	3800	18	1775	1150	30	27	2400	1650	725	350
20	4450	3150	20	1450	950	32	16.5	2175	1475	650	300
22	3800	2700	22	1225	800	33.5	0	2000	1375	600	250
24	3300	2350	24	1025	650						
26	2900	2050	26	875	525						
27	2750	1925	27	850	475						

NOTES:

OPERATE WITH JIB BY RADIUS WHEN MAIN BOOM IS FULLY EXTENDED AND BY BOOM ANGLE WHEN MAIN BOOM IS PARTIALLY EXTENDED. DO NOT EXCEED JIB CAPACITIES AT ANY PARTIALLY EXTENDED BOOM LENGTH.

SHADED AREAS ARE GOVERNED BY STRUCTURAL STRENGTH. DO NOT RELY ON TIPPING.

OPERATION OF THIS EQUIPMENT IN EXCESS OF RATING CHARTS AND DISREGARD OF INSTRUCTIONS IS DANGEROUS AND VOIDS WARRANTY.

1) The rated loads are the maximum lifting capacities as determined by operating radius only. Any combination of boom lengths and angles may be used to obtain operating radius. The operating radius is the horizontal distance from a projection of the axis of rotation to the supporting surface, before loading, to the center of vertical hoist line or tackle with load applied.

2) The rated loads shown on outriggers do not exceed 85% of actual tipping. The rated loads shown on rubber do not exceed 75% of actual tipping. These ratings are based on freely suspended loads with the crane leveled, standing on a firm, uniform, supporting surface. Practical working loads depend on supporting surface, operating radius, and other factors affecting stability. Hazardous surroundings, climatic conditions, experience of personnel, and proper training must all be taken into account by the operator.

3) The weights of all load handling devices such as hooks, hook blocks, slings, etc., except the hoist rope, shall be considered as part of the load. See reduction chart.

4) Ratings on outriggers are with outriggers fully extended.

5) Ratings on rubber depend on tire capacity, condition of tires and proper inflation pressure (100 psi). Loads on rubber may be transported at a maximum speed of 2.5 mph on a smooth, hard, level surface with boom retracted to the shortest length possible and centered over front.

6) For operating radius not shown, use load rating of next larger radius.

7) The maximum combined total boom and deck load is 12,000 lb. The maximum deck load only is 14,000 lb.

8) Do not induce any external side loads to boom or jib.

80017679CD

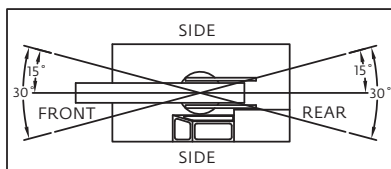

REDUCTION CHART		
	FROM MAIN BOOM RATINGS	FROM JIB RATINGS
MAIN BLOCK	140 lb	N/A
HOOK & BALL	100 lb	100 lb
JIB, STOWED	0 lb	N/A
JIB, DEPLOYED	150 lb	0 lb

RIGGING CHART	
1-PART 0 - 8500 lb	2-PART 0 - 17,000 lb
WIRE ROPE: 1/2 inch diameter Minimum breaking strength 29,750 lb	

Load chart

CD3330FL (Four-section boom)

Radius (ft)	4-SECTION MAIN BOOM W/ 4TH RETRACTED			
	ON OUTRIGGERS (lb)		ON RUBBER (lb)	
	F/R	360°	F/R	360°
5	17000	17000	10000	10000
6	15700	14400	9500	8200
8	12400	10800	8000	5600
10	10200	8500	5400	3800
12	8500	6950	3800	2700
14	7100	5800	2750	1950
16	6000	4650	2150	1450
18	5200	3800	1800	1150
20	4450	3150	1500	950
22	3800	2700	1300	775
24	3300	2350	1100	600
26	2900	2050	900	450
27	2750	1925	825	375

Radius (ft)	4-SECTION MAIN BOOM W/ 4TH EXTENDED			
	ON OUTRIGGERS (lb)		ON RUBBER (lb)	
	F/R	360°	F/R	360°
5	-	-	-	-
6	-	-	-	-
8	4900	4900	4900	4900
10	4300	4300	4300	4250
12	3800	3800	3800	3300
14	3400	3400	3400	2600
16	3100	3100	2900	2100
18	2900	2900	2400	1700
20	2900	2900	1950	1350
22	2900	2900	1600	1050
24	2900	2650	1350	850
26	2900	2300	1100	700
27	2900	2150	1000	650
28	2750	2000	925	600
30	2450	1800	800	500
32	2200	1600	700	400
33.5	1975	1400	625	325
36	1775	1250	550	250

NOTES:

OPERATE WITH JIB BY RADIUS WHEN MAIN BOOM IS FULLY EXTENDED (WITH 4TH SECTION EXTENDED OR RETRACTED) AND BY BOOM ANGLE WHEN MAIN BOOM IS PARTIALLY EXTENDED. DO NOT EXCEED JIB CAPACITIES AT ANY PARTIALLY EXTENDED BOOM LENGTH.

SHADED AREAS ARE GOVERNED BY STRUCTURAL STRENGTH. DO NOT RELY ON TIPPING.

OPERATION OF THIS EQUIPMENT IN EXCESS OF RATING CHARTS AND DISREGARD OF INSTRUCTIONS IS DANGEROUS AND VOIDS WARRANTY.

Radius (ft)	LOADED BOOM ANGLE (deg)	4-SECTION MAIN BOOM W/ 4TH RETRACTED W/ 6 FT JIB DEPLOYED			
		ON OUTRIGGERS (lb)		ON RUBBER (lb)	
		F/R	360°	F/R	360°
16.4	60	3500	3500	2000	1300
18	57.5	3375	3375	1800	1150
20	53.5	3225	3150	1500	950
22	49	3075	2700	1300	800
24	44.5	2950	2350	1100	650
26	39.5	2850	2050	925	525
28	34	2625	1825	800	425
30	27	2400	1650	725	350
32	16.5	2175	1475	650	300
33.5	0	2000	1375	600	250

Radius (ft)	LOADED BOOM ANGLE (deg)	4-SECTION MAIN BOOM W/ 4TH EXTENDED W/ 6 FT JIB DEPLOYED			
		ON OUTRIGGERS (lb)		ON RUBBER (lb)	
		F/R	360°	F/R	360°
22	60	2900	2900	1600	1050
24	57	2900	2650	1350	850
26	54	2900	2300	1100	700
28	50.5	2750	2000	925	600
30	47	2450	1800	800	500
32	43	2200	1600	700	400
33.5	40	1975	1400	625	325
36	34.5	1775	1250	550	250
38	29	1650	1150	500	200
40	22.5	1550	1075	450	150
42	11.5	1450	1000	400	125
43	0	1400	950	375	100

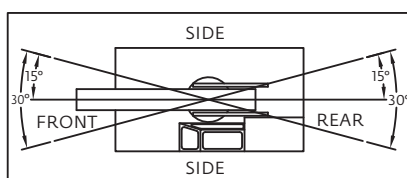

REDUCTION CHART		
	FROM MAIN BOOM RATINGS	FROM JIB RATINGS
MAIN BLOCK	140 lb	N/A
HOOK & BALL	100 lb	100 lb
JIB, STOWED	0 lb	N/A
JIB, DEPLOYED	150 lb	0 lb

RIGGING CHART	
1-PART 0 - 8500 lb	2-PART 0 - 17000 lb
WIRE ROPE: 1/2 inch diameter Minimum breaking strength 29,750 lb	

1) The rated loads are the maximum lifting capacities as determined by operating radius only. Any combination of boom lengths and angles may be used to obtain operating radius. The operating radius is the horizontal distance from a projection of the axis of rotation to the supporting surface, before loading, to the center of vertical hoist line or tackle with load applied.

2) The rated loads shown on outriggers do not exceed 85% of actual tipping. The rated loads shown on rubber do not exceed 75% of actual tipping. These ratings are based on freely suspended loads with the crane leveled, standing on a firm, uniform, supporting surface. Practical working loads depend on supporting surface, operating radius, and other factors affecting stability. Hazardous surroundings, climatic conditions, experience of personnel, and proper training must all be taken into account by the operator.

3) The weights of all load handling devices such as hooks, hook blocks, slings, etc., except the hoist rope, shall be considered as part of the load. See reduction chart.

4) Ratings on outriggers are with outriggers fully extended.

5) Ratings on rubber depend on tire capacity, condition of tires and proper inflation pressure (100 psi). Loads on rubber may be transported at a maximum speed of 2.5 mph on a smooth, hard, level surface with boom retracted to the shortest length possible and centered over front.

6) For operating radius not shown, use load rating of next larger radius.

7) The maximum combined total boom and deck load is 12,000 lb. The maximum deck load only is 14,000 lb.

8) Do not induce any external side loads to boom or jib.

80017731

Dimensions

CD3339

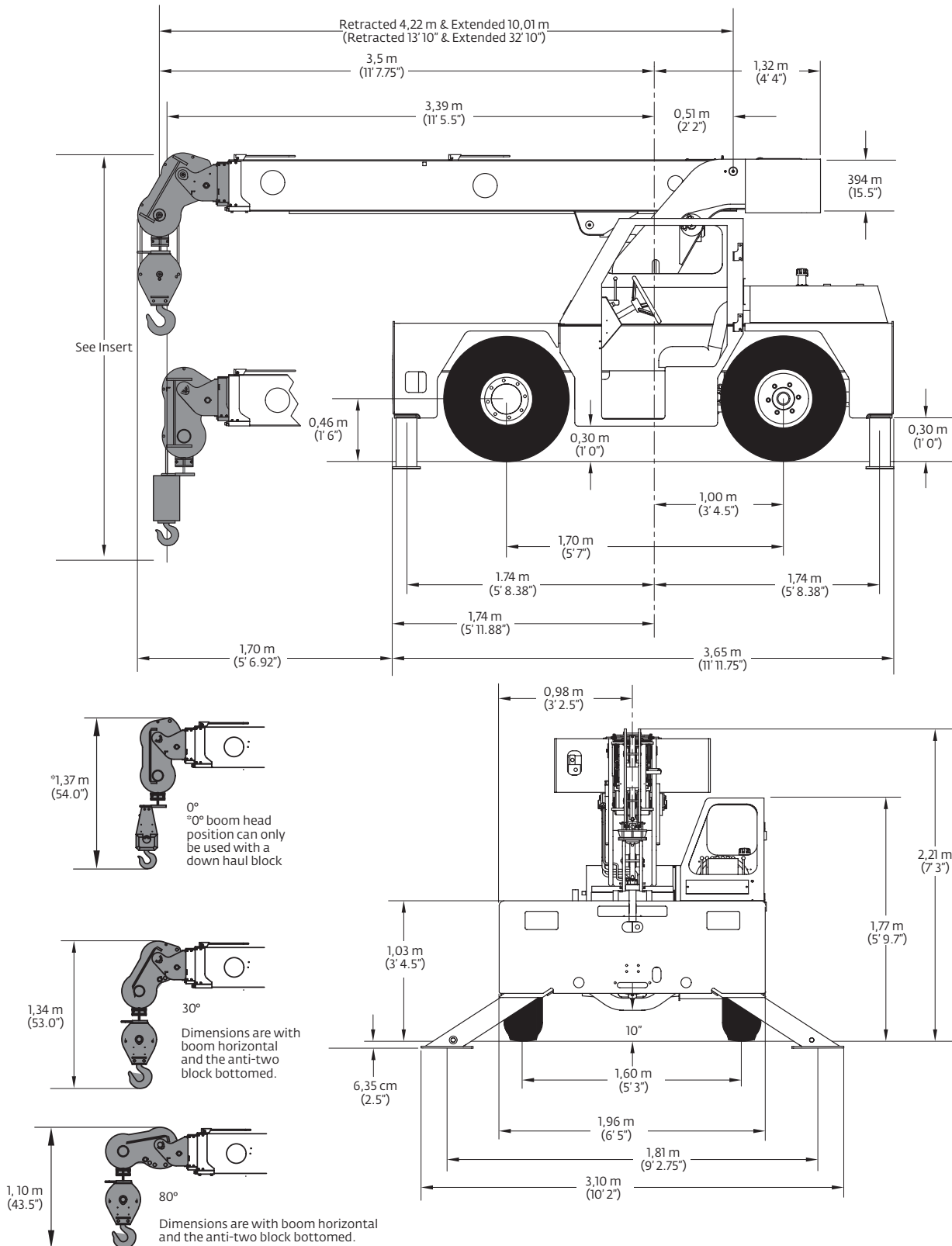

Range diagram

CD3339

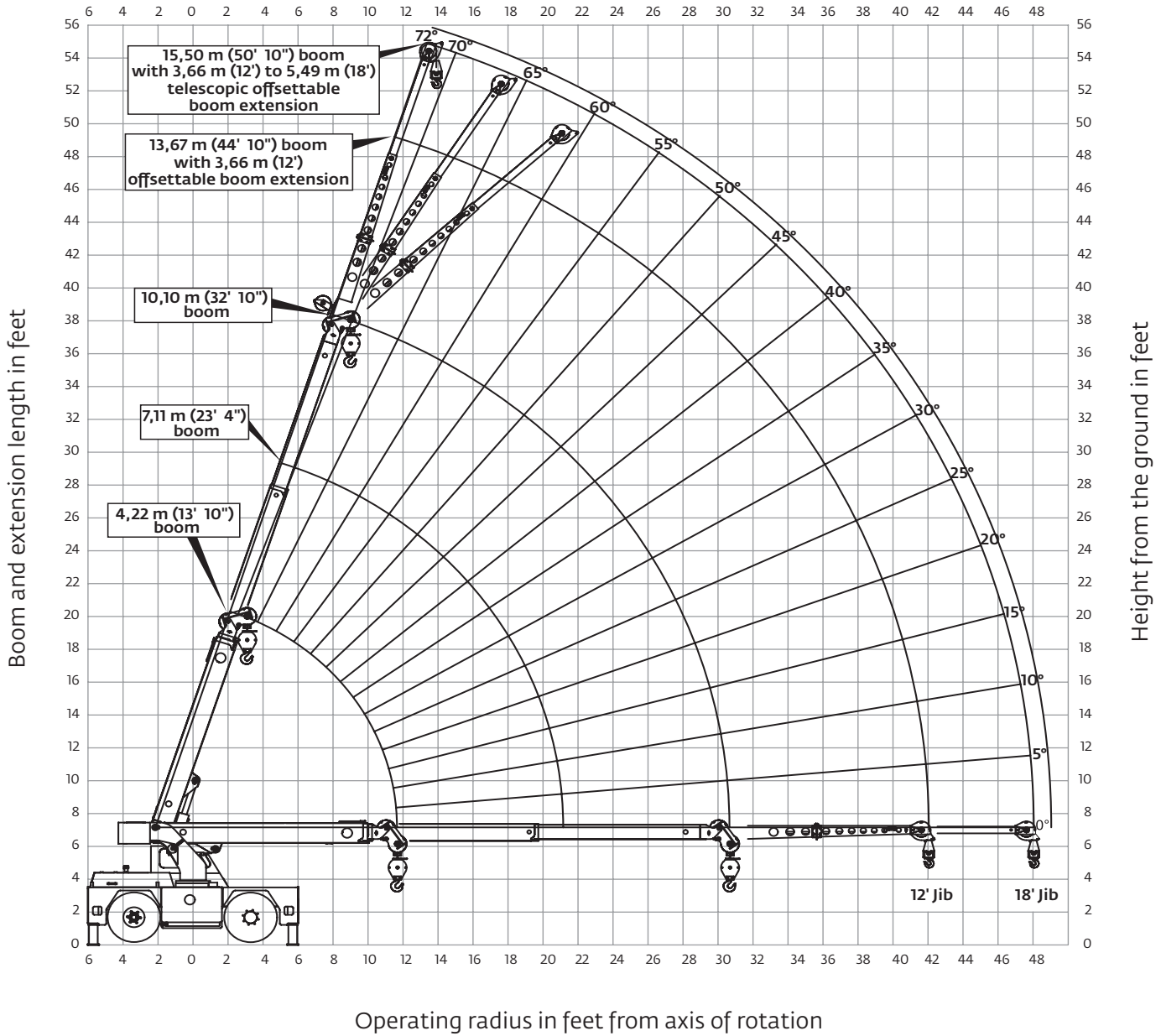

Load chart

CD3339

	RADIUS (ft)	ON OUTRIGGERS (lb)				ON RUBBER(lb)		
		F/R		360°		F/R	360°	
		BOOM RETRACTED	BOOM EXTENDED	BOOM RETRACTED	BOOM EXTENDED	ANY BOOM	ANY BOOM	
MAIN BOOM	5.0	18,000	14,700	18,000	14,700	11,500	9400	
	6.0	15,700	14,400	15,000	14,400	10,000	7500	
	8.0	12,200	12,200	11,400	11,400	8100	5040	
	10.0	10,200	10,200	9100	9100	5480	3530	
	12.0	8400	8400	7600	7600	3920	2590	
	14.0	-	7200	-	6500	3040	1970	
	16.0	-	6200	-	5310	2420	1560	
	18.0	-	5400	-	4340	1970	1250	
	20.0	-	4830	-	3610	1640	1020	
	22.0	-	4000	-	3030	1370	850	
	24.0	-	3480	-	2590	1160	710	
	26.0	-	3020	-	2250	990	590	
	28.0	-	2680	-	2010	830	490	
	31.0	-	2270	-	1740	650	360	
	JIB	34.0	-	1960	-	1500	510	250
		36.0	-	1770	-	1350	430	180
38.0		-	1590	-	1200	350	130	
40.0		-	1420	-	1050	280	80	
42.0		-	1270	-	930	210	60	
44.0		-	1200	-	880	190	40	
46.0		-	1160	-	820	170	20	
48.0		-	1110	-	760	140	0	

MAIN BOOM ANGLE (deg)	JIB STRUCTURAL CAPACITIES (lb)					
	12 ft JIB			18 ft JIB		
	0° OFFSET	15° OFFSET	30° OFFSET	0° OFFSET	15° OFFSET	30° OFFSET
72	7500	5100	3500	4000	3300	2300
70	7000	4800	3400	3750	3100	2200
65	5700	4100	3100	3200	2700	2000
60	4500	3500	2800	2800	2400	1850
55	3500	3000	2550	2450	2150	1700
50	2800	2500	2300	2150	1950	1600
45	2300	2200	2000	1900	1750	1500
40	2000	1900	1800	1700	1600	1400
35	1775	1675	1600	1525	1450	1350
30	1600	1500	1400	1400	1300	1300
25	1450	1400	-	1275	1200	-
20	1350	1350	-	1175	1125	-
15	1300	1300	-	1100	1100	-
10	1275	-	-	1050	-	-
5	1225	-	-	1025	-	-
0	1200	-	-	1000	-	-

NOTES:

JIB CAPACITY IS LIMITED BY BOTH STRUCTURAL CAPACITY CHART AND MAIN CAPACITY CHART.

SHADED AREAS ARE GOVERNED BY STRUCTURAL STRENGTH, DO NOT RELY ON TIPPING.

OPERATION OF THIS EQUIPMENT IN EXCESS OF RATING CHARTS AND DISREGARD OF INSTRUCTIONS IS DANGEROUS AND VOIDS WARRANTY.

1) The rated loads are the maximum lifting capacities as determined by operating radius only. Any combination of boom lengths and angles may be used to obtain operating radius. The operating radius is the horizontal distance from a projection of the axis of rotation to the supporting surface, before loading, to the center of vertical hoist line or tackle with load applied.

2) The rated loads shown on outriggers do not exceed 85% of actual tipping. The rated loads shown on rubber do not exceed 75% of actual tipping. These ratings are based on freely suspended loads with the crane leveled, standing on a firm, uniform, supporting surface. Practical working loads depend on supporting surface, operating radius, and other factors affecting stability. Hazardous surroundings, climatic conditions, experience of personnel, and proper training must all be taken into account by the operator.

3) The weights of all load handling devices such as hooks, hook blocks, slings, etc., except the hoist rope, shall be considered as part of the load. See reduction chart.

4) Ratings on outriggers are with outriggers fully extended.

5) Ratings on rubber depend on tire capacity, condition of tires and proper inflation pressure (100 psi). Loads on rubber may be transported at a maximum speed of 2.5 mph on a smooth, hard, level surface with boom retracted to the shortest length possible and centered over front.

6) For operating radius not shown, use load rating of next larger radius.

7) The maximum combined total boom and deck load is 12,000 lb. The maximum deck load only is 14,000 lb.

8) Do not induce any external side loads to boom or jib.

1303154CD

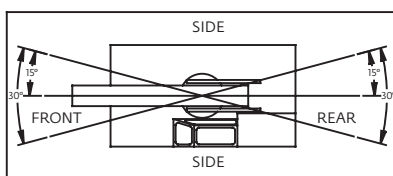

REDUCTION CHART		
	FROM MAIN BOOM RATINGS	FROM MAIN JIB RATINGS
MAIN BLOCK	140 lb	N/A
HOOK & BALL	100 lb	100 lb
JIB, STOWED	0 lb	N/A
JIB, DEPLOYED	450 lb	0 lb

RIGGING CHART	
 1-PART 0 - 10,000 lb	 2-PART 0 - 18,000 lb
WIRE ROPE: 9/16 in diameter Min. breaking strength 35,000 lb	

Dimensions

CD3340B

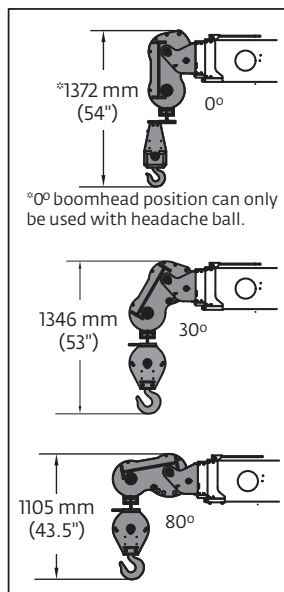
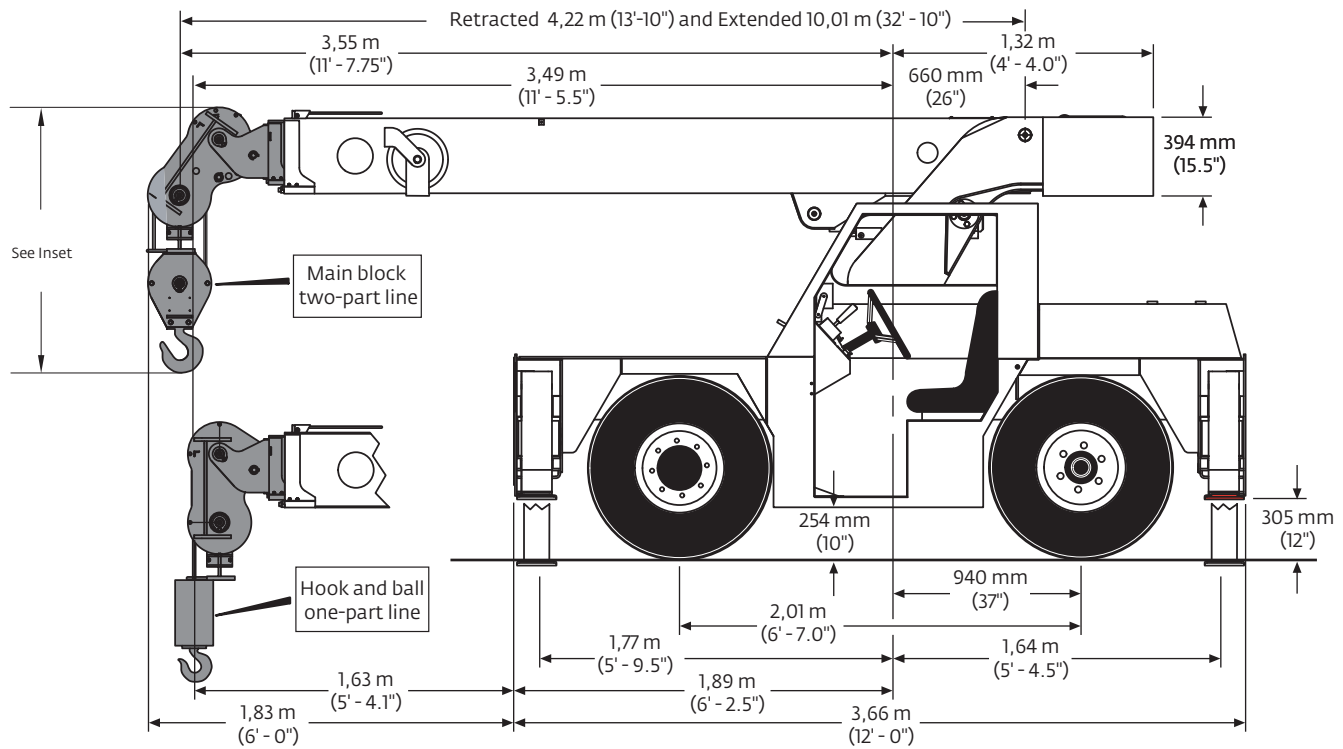

Dimensions are with the boom horizontal and the anti-two block bottomed.

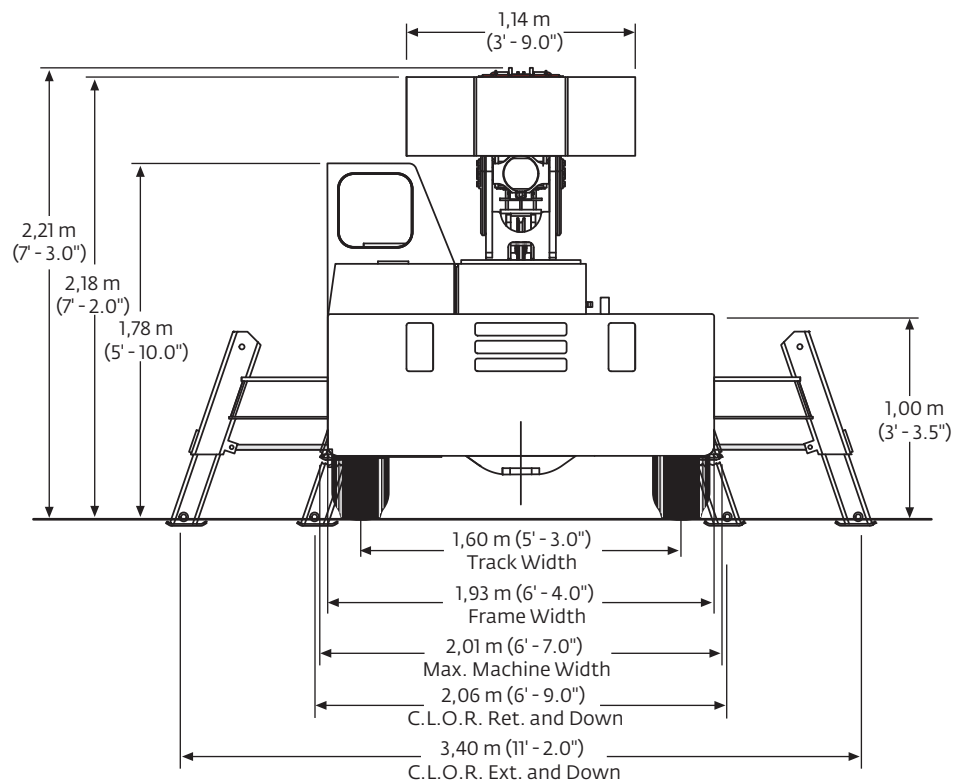

Range diagram

CD3340B

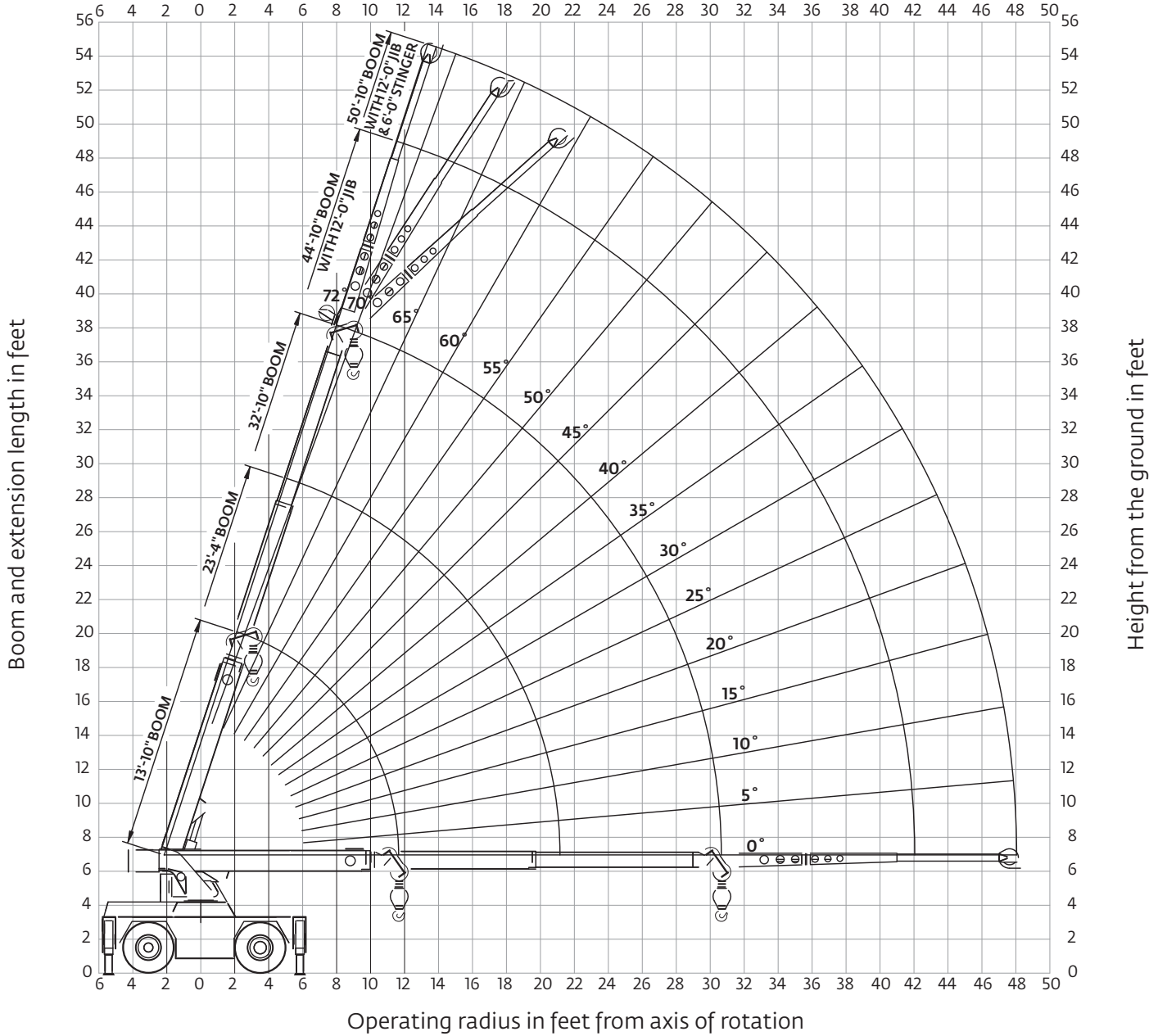

Load chart

CD3340B

	RADIUS (ft)	ON OUTRIGGERS (lb)				ON RUBBER (lb)		MAIN BOOM ANGLE (deg)	JIB STRUCTURAL CAPACITIES (lb)					
		EXTENDED 360° RETRACTED F/R		RETRACTED 360°		F/R	360°		12 ft JIB			18 ft JIB		
		BOOM RETRACTED	BOOM EXTENDED	BOOM RETRACTED	BOOM EXTENDED	ANY BOOM	ANY BOOM		0° OFFSET	15° OFFSET	30° OFFSET	0° OFFSET	15° OFFSET	30° OFFSET
MAIN BOOM	4.0	21,000	15,000	19,625	13,975	11,500	11,500	72	7500	5100	3500	4000	3300	2300
	5.0	18,000	14,700	16,800	13,700	11,500	9400	70	7000	4800	3400	3750	3100	2200
	6.0	15,700	14,400	13,400	13,400	10,000	7800	65	5700	4100	3100	3200	2700	2000
	8.0	12,200	12,200	8700	8700	7600	5600	60	4500	3500	2800	2800	2400	1850
	10.0	10,200	10,200	6150	6150	5175	3875	55	3500	3000	2550	2450	2150	1700
	12.0	8400	8400	4550	4550	3850	2875	50	2800	2500	2300	2150	1950	1600
	14.0	-	7100	-	3425	3000	2250	45	2300	2200	2000	1900	1750	1500
	16.0	-	6000	-	2775	2400	1800	40	2000	1900	1800	1700	1600	1400
	18.0	-	5000	-	2300	1975	1475	35	1775	1675	1600	1525	1450	1350
	20.0	-	4300	-	1825	1650	1200	30	1600	1500	1400	1400	1300	1300
	22.0	-	3700	-	1550	1400	1000	25	1450	1400	-	1275	1200	-
	24.0	-	3300	-	1275	1200	850	20	1350	1350	-	1175	1125	-
	26.0	-	2900	-	1075	1025	700	15	1300	1300	-	1100	1100	-
	28.0	-	2600	-	950	875	600	10	1275	-	-	1050	-	-
	31.0	-	2300	-	800	700	450	5	1225	-	-	1025	-	-
JIB	34.0	-	1975	-	650	600	350	0	1200	-	-	1000	-	-
	36.0	-	1775	-	550	500	275							
	38.0	-	1575	-	450	400	200							
	40.0	-	1425	-	350	300	125							
	42.0	-	1300	-	250	200	-							
	44.0	-	1200	-	200	150	-							
	46.0	-	1100	-	175	-	-							
	48.0	-	1000	-	150	-	-							

NOTES:

JIB CAPACITY IS LIMITED BY BOTH STRUCTURAL CAPACITY CHART AND MAIN CAPACITY CHART.

SHADED AREAS ARE GOVERNED BY STRUCTURAL STRENGTH, DO NOT RELY ON TIPPING.

OPERATION OF THIS EQUIPMENT IN EXCESS OF RATING CHARTS AND DISREGARD OF INSTRUCTIONS IS DANGEROUS AND VOIDS WARRANTY.

1) The rated loads are the maximum lifting capacities as determined by operating radius, boom extension and boom angle. The operating radius is the horizontal distance from a projection of the axis of rotation to the supporting surface, before loading to the center of vertical hoist line or tackle with load applied.

2) The rated loads shown on outriggers do not exceed 85% of actual tipping. The rated loads shown on rubber do not exceed 75% of actual tipping. Retracted outrigger rated loads meet ASME B30.5-2004. These ratings are based on freely suspended loads with the crane leveled, standing on a firm, uniform, supporting surface. Practical working loads depend on supporting surface, operating radius, and other factors affecting stability. Hazardous surroundings, climatic conditions, experience of personnel, and proper training must all be taken into account by the operator.

3) The weights of all load handling devices such as hooks, hook blocks, slings, etc., except the hoist rope, shall be considered as part of the load. See reduction chart.

4) Ratings on outriggers are for either outriggers fully extended and down or fully retracted and down. Ratings for outriggers fully retracted and down will apply for any intermediate outrigger setting.

5) Ratings on rubber depend on tire capacity, condition of tires and proper inflation pressure (125 psi). Loads on rubber may be transported at a maximum speed of 2.5 mph on a smooth, hard level surface with boom retracted to the shortest length possible and centered over front.

6) For operating radius not shown, use load rating of next larger radius.

7) The maximum combined total boom and deck load is 12,000 lb. The maximum deck load only is 14,000 lb.

8) Do not induce any external side loads to boom or jib.



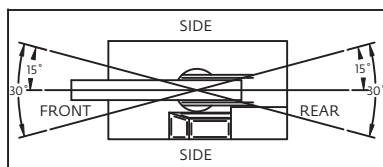





























80016880CD



REDUCTION CHART		
	FROM MAIN BOOM RATINGS	FROM JIB RATINGS
MAIN BLOCK	140 lb	N/A
HOOK & BALL	100 lb	100 lbs
JIB, STOWED	0 lb	N/A
JIB, DEPLOYED	450 lb	0 lb

RIGGING CHART	
 1-PART 0-10,000 lb	 2-PART 0-21,000 lb
WIRE ROPE: 9/16 inch diameter Min. breaking strength 36,750 lb	

Symbols glossary

 Axles	 Counterweight	 Grade	 Outriggers
 Boom	 Drive	 Heavy duty jib	 Radius
 Boom elevation	 Electrical system	 Hoist	 Rotation
 Boom extension	 Engine	 Hookblock	 Speed
 Boom length	 Extension	 Hydraulic system	 Steering
 Boom nose	 Frame	 Lights	 Suspension
 Brakes	 Fuel tank capacity	 Oil	 Swing
 Cab	 Gear	 Outrigger controls	 Tires
			 Transmission



Notes

Regional headquarters

Manitowoc - Americas

Manitowoc, Wisconsin, USA

Tel: +1 920 684 6621

Fax: +1 920 683 6277

Shady Grove, Pennsylvania, USA

Tel: +1 717 597 8121

Fax: +1 717 597 4062

Manitowoc - Europe, Middle East & Africa

Ecully, France

Tel: +33 (0)4 72 18 20 20

Fax: +33 (0)4 72 18 20 00

Manitowoc - Asia Pacific

Shanghai, China

Tel: +86 21 6457 0066

Fax: +86 21 6457 4955

Regional offices

Americas

Brazil

Alphaville

Mexico

Monterrey

Chile

Santiago

Portugal

Baltar

Russia

Moscow

U.A.E.

Dubai

U.K.

Gawcott

Europe, Middle East & Africa

Czech Republic

Netvorice

France

Baudemont

Cergy

Decines

Germany

Langenfeld

Hungary

Budapest

Italy

Parabiago

Netherlands

Breda

Poland

Warsaw

Asia - Pacific

Australia

Brisbane

Melbourne

Sydney

China

Beijing

Chengdu

Guangzhou

India

Hyderabad

Pune

Korea

Seoul

Philippines

Makati City

Singapore

Factories

Brazil

Alphaville

China

TaiAn

Zhangjiagang

France

Charlieu

La Clayette

Moulins

Germany

Wilhelmshaven

India

Pune

Italy

Niella Tanaro

Portugal

Baltar

Fânzeres

Slovakia

Saris

USA

Manitowoc

Port Washington

Shady Grove

This document is non-contractual. Constant improvement and engineering progress make it necessary that we reserve the right to make specification, equipment, and price changes without notice. Illustrations shown may include optional equipment and accessories and may not include all standard equipment.