



# Specifications

Lattice Boom Truck Crane

## HC-108D

50 Ton (45.39 metric ton)

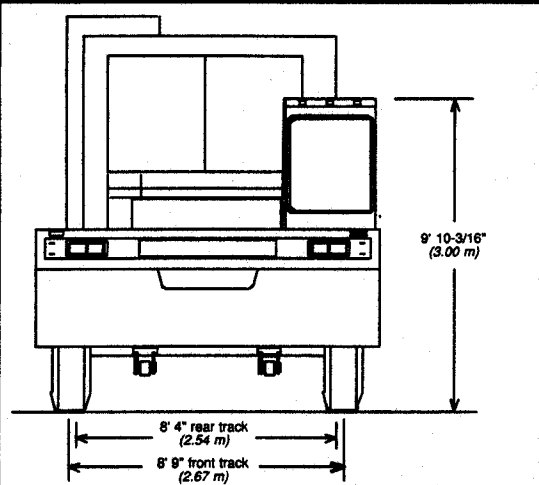
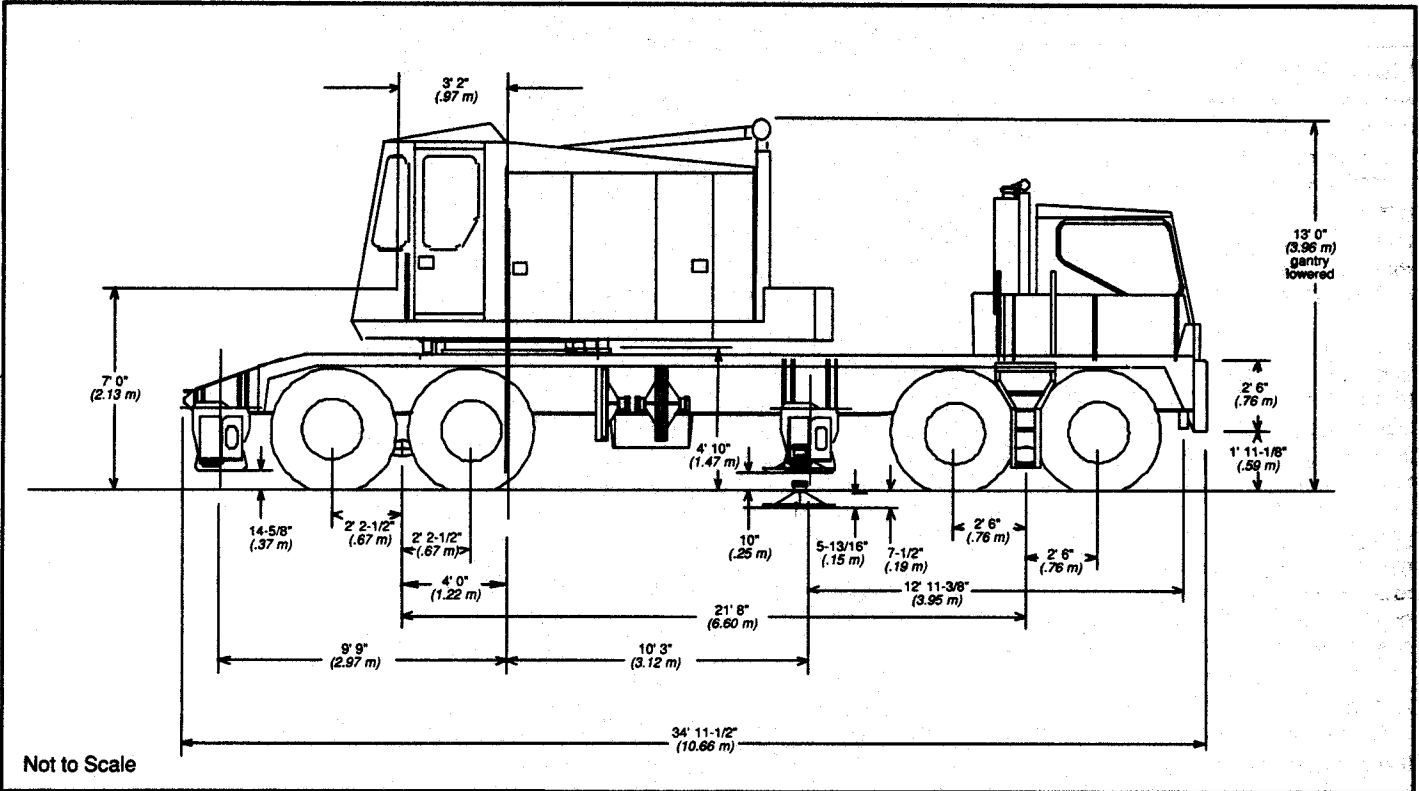

General dimensions	feet	meters
Basic angle boom length	40' 0"	12.19
Overall width, outriggers extended (over floats)	22' 0"	6.71
Overall width, outriggers extended (c/l of jacks)	19' 6"	5.94
Overall width, outriggers retracted (floats removed)	11' 0"	3.35
Minimum ground clearance	12-1/2"	.32
Ground clearance under counterweight with machine on tires	5' 0"	1.52
Counterweight "A" tailswing (across corners)	11' 5"	3.48
Counterweight "AB" tailswing (across corners)	11' 10"	3.61
Overall cab width (upper)	8' 5-3/8"	2.57
Radius of boom hinge pin	3' 2"	.97
Height of boom hinge pin	7' 0"	2.13

# Axle Loads

Basic HC-108D upper machinery with standard 19,200 lb. (8 709 kg) counterweight and GM 4-71N diesel engine; mounted on a Link-Belt 260" (6.60 m) wheelbase, 8 x 4 carrier 11' 0" (3.35 m) wide equipped with DD 6V-92TA diesel engine, 14.00 x 20J (18 ply) rating tires, hydraulic outrigger assemblies complete with five floats.	Basic Machine Weight		Upper facing front				Upper facing rear			
			Front axle		Rear axle		Front axle		Rear axle	
	Upper: 43,885 lbs. (19 906 kg)	Carrier: 48,780 lbs. (22 127 kg)	Total: 92,665 lbs. (42 033 kg)	lbs.	kg	lbs.	kg	lbs.	kg	lbs.
			-3,425	-1 554	47,310	21 460	19,630	8 904	24,255	11 002
			23,260	10 551	25,520	11 576	23,260	10 551	25,520	11 576
			19,835	8 770	72,830	33 036	42,890	19 455	49,775	22 578
<b>Upper Machinery</b>										
Rear drum load lowering clutch	500	227	20	9	480	218	165	75	335	152
Rear drum planetary	450	204	15	7	435	197	150	68	300	136
Rear drum rope - 769' (234.39 m), 5/8" (16 mm) type "N" (jib hoist line)	554	251	20	9	534	242	185	84	369	167
Front drum load lowering clutch	400	181	50	23	350	159	95	43	305	138
Front drum planetary	450	204	65	29	385	175	100	45	350	159
Front drum rope - 481' (146.61 m), 3/4" (19 mm) type "N" (main hoist line)	500	227	75	34	425	193	110	50	390	177
Third drum	850	386	190	86	660	299	125	57	725	329
Third drum rope - 297' (90.53 m), 5/8" (16 mm) type "N" (9" - .23 m - lagging)	214	97	50	23	164	74	30	14	184	83
Counterweight ("AB" for lifting crane)	-19,200	-8 709	5,070	2 300	-24,270	-11 009	-12,160	-5 516	-7,040	-3 193
Counterweight ("A" for dragline, clamshell, magnet)	-13,000	-5 897	3,425	1 554	-16,425	-7 450	-8,225	-3 731	-4,775	-2 166
<b>Attachment</b>										
12.19 m angle boom (with open throat section) and accessories	4,860	2 204	6,590	2 989	-1,730	-785	-4,795	-2 175	9,655	4 379
20' (6.10 m) angle boom base section with accessories	2,235	1 014	1,975	896	260	118	-1,150	-522	3,385	2 757
<b>Carrier</b>										
Front outrigger box, beams and jacks	-5,200	-2 359	-3,420	-1 551	-1,780	-807	-3,420	-1 551	-1,780	-807
Rear outrigger box, beams and jacks	-5,200	-2 359	1,380	626	-6,580	-2 985	1,380	626	-6,580	-2 985
Four floats (main)	-500	-227	-140	-64	-360	-163	-140	-64	-360	-163
Front center hydraulic jack float	-130	-59	-60	-27	-70	-32	-60	-27	-70	-32
14R20M radial tires	435	197	145	66	290	131	145	66	290	131

Note: All weights are ± 3%

## Carrier

### Type

260" (6.60 m) wheelbase; 8 x 4 drive, 11' 0" (3.35 m) wide.

**Frame** - Main members heat treated alloy steel, triple-box construction. Machined mounting surface for turntable bearing. Towing shackles front and rear.

**Turntable bearing** - Inner race, with integral swing (ring) gear mounted on carrier.

### Outriggers

Full width, double-box front and rear, pin connected to carrier frame. Hydraulically operated beams and jack cylinders individually controlled from each side of carrier. Check valve at each jack cylinder. **Optional** - Hydraulic outrigger box pin puller.

**Front Center Hydraulic Jack** - Single hydraulic jack, with float, mounted at front of the carrier. Jack assembly required for handling 360° capacities.

**Floats** - 30" (.76 m) square alloy steel.

### Axles

**Front** - Tubular; bogie beam mounted tandem axles, single wheels. 105" (2.67 m) track.

**Rear** - Double reduction bogie mounted tandem axles, dual wheels. 100" (2.54 m) track.

**Suspension** - Hendrickson rubber bushed front and bronze bushed rear equalizer beams with rubber bushed torque rods.

**Wheels and rims** - Front and rear; cast spoke type.

**Tag axle** - *Optional*; consult factory.

### Tires

Single tires front; dual tires rear.

Standard - 14.00 x 20J (18 ply rating) transport type tread.

*Optional* - 14R20M (22 ply rating) transport type tread.

### Brakes

**Air brake system.**

**Service** - Dual circuit with modulated emergency brakes. Bendix dual circuit 8 wheel air brakes with service chambers on 4 front wheels and spring applied, air released emergency, parking, service chambers on 4 rear wheels. Air dryer standard.

**Size -**

Rear wheels: 16-1/2" x 7" (.42 x .18 m)  
Front wheels: 16-1/2" x 6" (.42 x .15 m)

**Steering**

Sheppard full integral hydraulic power. Steering mounted high on side of frame to minimize exposure to hazards. High speed, high power system to maximize maneuverability both on the job site and on the road.

**Engine**

Diesel; 12 volt alternator, starter, air compressor, dry type air cleaner, pressure lubrication and hydraulic pump.

Detroit Diesel 6V-92TA diesel engine, 6 cylinder.

Clutch - Lipe-Rollway 14" (.36 m) two plate, dry disc.

**Transmission**

Main - Eaton RTX 11715, 15 speeds forward, three reverse.

Auxiliary - Eaton AT-1202, 2 speed, midship mounting.

**Carrier Cab**

One-man, fully enclosed. Suspension mounted bucket seat with seat belt. Noise absorbing insulation with vinyl covering, sound reduction headliner. Rubber mounted for sound level reduction. Instrument panel and dash include speedometer, odometer, voltmeter, and gauges for fuel, engine temperature, air and oil pressures. Low air pressure warning buzzer, locking switch, starter, fire extinguisher, heater and defroster, windshield wiper and windshield washer. Tilt and telescope steering column. Sliding right and rear windows, roll down door window, front and roof fresh air vents.

**Electrical System**

12-volt; including dual sealed beam headlights, directional signals with 4-way flashing system, stop and tail lights, clearance lights, horn, lighting of instrument panel, dome light, headlight dimmer switch, and two 12-volt, 8D batteries. Individual switches provide circuit control for hydraulic outrigger solenoid valves; one control station on each side of carrier.

**Fuel Tank**

One 85 gallon (322 liter) capacity tank; side mounted on carrier frame.

**Standard Auxiliary Equipment**

West coast type rear view mirrors with adjustable convex mirrors, lug wrench, 2-way reading bubble levels.

**Standard Auxiliary Equipment (con't)**

High pressure lube fittings at all bearing points. Hand grab rails, carrier deck access ladders on both sides and rear, back-up alarm, skid-resistant finish on carrier deck.

Engine Specifications	Detroit Diesel 6V-92TA
Number of cylinders	6
Bore	4.84" (.12 m)
Stroke	5" (.13 m)
Piston displacement	552 cu. in. (9 046 cm <sup>3</sup> )
Max. brake h.p. @ rpm	350 (261 kw) @ 2,100
Governed load speed rpm	2,100
Peak torque @ rpm	995 ft. lbs. (1 349 j) @ 1,200
Electrical system	12-volt charging/starting
Batteries	Two 12-volt
Air compressor	Bendix TU-FLO 700

**Carrier Speeds**

Main - Eaton RTX 11715			Auxiliary - Eaton AT 1202			
			1.00:1.00		2.036:1.00	
	Gear	Ratio	mph	km/h	mph	km/h
High	10th	1.78	50.0	80.5	24.5	39.5
	9th	1.00	39.0	62.7	19.1	30.9
	8th	1.30	30.0	48.2	14.7	23.7
	7th	1.68	23.2	37.3	11.4	18.3
	6th	2.19	17.7	28.5	8.7	14.0
	Rev.	2.16	18.1	29.1	8.9	14.4
Low	5th	2.81	13.9	22.4	6.8	11.0
	4th	3.57	10.9	17.5	5.3	8.6
	3rd	4.63	8.5	13.6	4.2	6.7
	2nd	6.00	6.5	10.4	3.2	5.2
	1st	7.83	5.0	8.0	2.4	3.9
	Rev.	7.73	5.1	8.2	2.4	3.9
Deep Reduction	5th	4.34	9.0	14.6	4.4	7.1
	4th	5.52	7.1	11.4	3.7	5.6
	3rd	7.16	5.5	8.8	2.7	4.3
	2nd	9.27	4.2	6.7	2.1	3.4
	1st	12.10	3.2	5.2	1.6	2.7
	Rev.	11.95	3.2	5.2	1.6	2.7

Creep speed in deep reduction low (1st) - based on peak engine torque speed of 1,200 rpm - is .93 mph (1.52 km/h).

Note: Rear axle ratio - 7.24 to 1.0.

**Turning Ability**

Turning circle diameter	Curb clearance circle diameter	Vehicle clearance circle diameter
Centerline of outer front tire	Outside of outer front tire	Outer outside of front bumper
98' 6" (30.02 m)	99' 10" (30.43 m)	104' 2" (31.75 m)

# HC-108D Load Hoisting Performance

Available line speed and line pull - based on GM 4-71N at full load speed and first layer of wire rope on drum.  
Line pulls are not based on wire rope strength. See wire rope chart below for maximum permissible single part of line working loads.

## Line Speeds and Pulls

Attachment	Front or Rear Drum							Third Drum						
	Root dia.	Wire rope dia.		Line speed - first layer		Line pull - first layer		Root dia.	Wire rope dia.		Line speed - first layer		Line pull - first layer	
		inches	mm	fpm	m/min.	lbs.	kg		inches	mm	fpm	m/min.	lbs.	kg
Crane	15-1/4" (.39 m)	3/4	19	167	50.9	20,200	9 163	9" (.23 m)	5/8	16	120	36.6	10,000	4 536
Dragline hoist	15-1/4" (.39 m)	3/4	19	167	50.9	19,600	8 891							
Dragline inhaul	15-1/4" (.39 m)	7/8	22	173	52.7	20,000	9 072							
Clamshell holding or closing (hoist)	15-1/4" (.39 m)	3/4	19	167	50.9	20,200	9 163	Boomhoist Drum						
								9" (.23 m)	5/8	16	120	36.6	27,100	12 293

## Wire Rope: size, type and working strength

Wire rope application	Size: diameter		Type	Max. permissible load	
	inches	mm		lbs.	kg
Boomhoist	5/8	16	W	11,700	5 307
Main load hoist	3/4	19	N	16,800	7 620
Jib load hoist (1-part)	5/8	16	P	6,700	3 039
Jib load hoist (2-parts)	5/8	16	N	23,400	10 614
Third drum	5/8	16	N	11,700	5 307
Clamshell holding or closing (hoist)	3/4	19	N	16,800	7 620
Dragline hoist	3/4	19	N	16,800	7 620
Dragline inhaul	7/8	22	M	22,700	10 297
Boom pendants	1-1/4	32	N	53,200	24 132
Jib staylines	5/8	16	N	11,700	5 307

## Wire Rope: types available

- Type "M" - 6 x 25 (6 x 19 class) filler wire, extra improved plow steel, preformed, independent wire rope center, right lay, lang lay.
- Type "N" - 6 x 25 (6 x 19 class) filler wire, extra improved plow steel, preformed, independent wire rope center, right lay, regular lay.
- Type "W" - 6 x 25 (6 x 19 class) filler wire, extra improved plow steel, preformed, independent wire rope center, right lay, alternate lay.
- Type "P" - 19 x 7 non-rotating, extra improved plow steel, preformed.

## Revolving Upperstructure

### ■ Frame

All-welded, precision machined; machinery side housings bolted to upper frame.

### ■ Turntable Bearing

With integral swing (ring) gear. Inner race with integral internal swing gear is mounted on carrier; outer race is bolted to machined surface on upper revolving frame.

### ■ Engines

Full pressure lubrication, oil filter, air cleaner, hourmeter and hand throttle, electric control shutdown.

### ■ Fuel Tank

58 gallon (220 liter) capacity; equipped with fuel sight level gauge, flame arrester, and self-closing cap with locking eye for padlock.

Engine Specifications	GM 4-71N with friction clutch	GM 4-71N with torque converter
Number of cylinders	4	4
Bore and stroke: inch (mm)	4-1/4 x 5 108 x 127	4-1/4 x 5 108 x 127
Piston displacement - cu. in. - (cm <sup>3</sup> )	284 4 650	284 4 650
High idle speed - rpm	1,990	2,150
Engine rpm at full load speed	1,850	2,000
Net engine hp at full load speed	110 (82 027 W)	125 (93 213 W)
Peak torque - foot pounds - joules	351 476	372 504
Peak torque - rpm	1,200	1,200
Electrical system	12-volt	12-volt
Batteries	one 12-volt	one 12-volt
Clutch or power take-off	Friction clutch	Disconnect between engine and converter
Transmission		
- Number chain wheel teeth	161	161
- Number engine pinion teeth	17	28

## Power train

### ■ Transmission

Quadruple roller chain enclosed in oil tight chain case with integral chain lubrication pump for oil stream lubrication; oil flow indicator switch.

### ■ Machinery gear train

"Full Function" design; two-directional power available to all operating shafts; shafts mounted on anti-friction bearings in precision bored machinery side housings. All load hoisting/lowering, swing and boom hoist functions completely independent of one another. Components such as gears, pinions, chain wheels, brake drums and clutch spiders are involute splined to shafts. Drum gear/clutch drum assemblies are bolted together and mounted on shafts on anti-friction bearings. Machine-cut teeth on drum gears, pinions, spur gears and chain wheel.

**Reduction shaft** - Two-piece shaft, mounted in side housings on anti-friction bearings, joined by involute splined coupling.

**Drive pinions** - Two heat treated with machine-cut teeth, involute splined to shaft. Pinions mounted on shaft outside of machinery side housings.

## Principal operating functions

### ■ Control system

Speed-o-Matic power hydraulic control system requiring no bleeding. Variable operating pressure transmitted to all two-shoe clutch cylinders as required. System includes constant displacement, engine-driven, vane-type hydraulic pump to provide flow of oil; accumulator to maintain system operating pressure, unloader valve to control pressure in accumulator, relief valve to limit maximum pressure buildup in system, full-flow filter with 40 micron disposable filter element, and variable pressure control valves to control clutches and other operating cylinders.

## Principal operating functions (con't)

### ■ Load hoisting and lowering

Wire rope drum gear train (front and rear main, and optional third, operating drums) powered by chain transmission from engine. Speed-o-Matic power hydraulic clutch control of all load hoisting/lowering functions.

### ■ Front and rear main operating drums

Two-piece, removable, grooved laggings bolted to brake drums which are splined to shafts. Extended length shafts permit installation of optional power load lowering clutches.

**Lifting crane, clamshell or magnet operation:** 15-1/4" (.39 m) front and rear drum laggings grooved for 3/4" (19 mm) rope.

**Dragline operation:** 15-1/4" (.39 m) rear drum lagging grooved for 3/4" (19 mm) rope and 15-1/4" (.39 m) front drum lagging grooved for 7/8" (22 mm) rope.

**Third operating drum:** *Optional*; mounts forward of front main operating drum. Two-piece 9" (.23 m) root diameter lagging grooved for 5/8" (16 mm) rope bolted to brake drum which is splined to shaft.

**Note:** Third drum limitations:

**Dragline application:** Lagging must be removed from third drum. To prevent interference of inhaul rope with third drum brake enclosure it is necessary to use 10' (3.05 m) longer inhaul rope than normal to leave minimum of four wraps of rope at anchor end of drum.

**Lifting crane application:** To prevent interference of hoist line with third drum brake enclosure, quantity of line on front drum must be limited in certain cases. Four parts of 5/8" (16 mm) hoist line on 13-1/4" (.34 m) lagging may be used with booms up to 55' (16.76 m) in length at all radii. For longer boom lengths, operation is limited to certain radii and requires special investigation.

### ■ Drum clutches

Speed-o-Matic power hydraulic two-shoe clutches; internal expanding, lined shoes. Clutch spiders splined to shafts; clutch drums bolted to drum spur gears and mounted on shafts on anti-friction bearings.

### Load hoist clutches

Rear main operating drum - 20" (.51 m) diameter, 5" (.13 m) face width clutch drum; effective lining area 212 sq. in. (1 368 cm<sup>2</sup>).

Front and rear main operating drums - 20" (.51 m) diameter, 5" (.13 m) face width; effective lining area 212 sq. in. (1 368 cm<sup>2</sup>).

*Optional*; third operating drum - 17-1/4" (.44 m) diameter, 4" (101.60 mm) face width; effective lining area 118 sq. in. (761 cm<sup>2</sup>).

**Load lowering clutches** - Speed-o-Matic power hydraulic two-shoe clutches. Front and/or rear main operating drums - 20" (.51 m) diameter, 5" (.13 m) face width; effective lining area 212 sq. in. (1 368 cm<sup>2</sup>).

### Drum brakes

External contracting band; brake drum involute splined to shaft. Mechanically foot pedal operated; foot pedal equipped with latch to permit locking brake in applied position.

Front and rear main drums - Brakes 27" (.69 m) diameter, 4-1/2" (.11 m) face width; effective lining area 301 sq. in. (1 942 cm<sup>2</sup>).

Optional third drum - Brake 18" (.46 m) diameter, 3-1/2" (88.90 mm) face width; effective lining area 136 sq. in. (877 cm<sup>2</sup>).

### Drum rotation indicators

Standard for front and rear main operating drums. Two rotating dials mounted on control stand; dials actuated by flexible shaft drive from front or rear main operating drum.

### Swing system

Spur gear driven; single bevel gears (enclosed and running in oil) on horizontal swing shaft and vertical swing drive shaft. Swing pinion involute splined to vertical swing shaft, meshes with internal teeth of turntable bearing.

### Swing clutches

Speed-o-Matic power hydraulic two-shoe clutches. Standard: 20" (.51 m) diameter, 5" (.13 m) face width, lined shoes; effective lining area 212 sq. in. (1 368 cm<sup>2</sup>).

*Optional* - 20" (.51 m) diameter, 6-1/2" (.6 m) face width; effective lining area 300 sq. in. (1 678 cm<sup>2</sup>). Recommended for duty cycle work.

**Swing brake** - External contracting band; spring applied, power hydraulically released by operator controlled lever. Brake drum involute splined to swing brake shaft. Brake 14" (.36 m) diameter, 2-1/4" (57.15 mm) face width; effective lining area 74 sq. in. (477 cm<sup>2</sup>).

**Swing lock** - Mechanically controlled double pawl engages with internal teeth of turntable bearing.

**Swing speed** - 4.0 rpm.

### Boom/hoist lowering system

Independent, spur gear driven. Precision control boom hoisting and lowering through Speed-o-Matic power hydraulic two-shoe clutches.

### Boomhoist drum

Grooved, 9" (.23 m) root diameter, wire rope drum involute splined to shaft.

### Boomhoist drum locking pawl

Operator controlled, mechanically applied and released. Locking pawl engages ratchet teeth on flange of boomhoist drum to hold boom at fixed operating radius.

### Boomhoist/lowering clutches

Speed-o-Matic power hydraulic two-shoe clutches; one each for boom hoisting and lowering. 20" (.51 m) diameter, 5" (.13 m) face width; effective lining area 212 sq. in. (1 368 cm<sup>2</sup>).

### Boomhoist brake

One external contracting band brake; automatically spring applied, hydraulically released. Brake 22" (.56 m) diameter, 3" (76.20 mm) face width; effective lining area 174 sq. in. (1 123 cm<sup>2</sup>).

**Boomhoist limiting device** - Provided to restrict hoisting boom beyond recommended minimum radius; located on exterior right hand side of operator's cab.

### Electrical system

Battery; 12-volt, 225 ampere hour. *Optional*; battery lighting system including two adjustable floodlights located on cab front roof, one interior cab light, and automotive type wiring. *Optional*; additional 60 watt floodlight mounted on boom (three maximum quantity recommended).

### Operator's cab

Full-vision, equipped with safety glass panels. Operator's door is hinged; right window slides open. Standard equipment includes dry chemical fire extinguisher,

electric windshield wiper, cab heater, defroster fan, machinery guards, bubble-type level and hand grab rails.

### Machinery cab

Machinery access provided by hinged doors on sides and right front corner; rear doors roll on ball bearing rollers. Cab equipped with roof-top access ladder, electric warning horn, machinery guards, hand grab rails and skid-resistant finish on roof.

### Catwalks

*Optional*; for operator's side, or both sides of standard cab; include overhead hand grab rail on sides of cab.

### Gantry

Standard; retractable high gantry mounted on revolving upperstructure frame to rear of machinery side housing to support boom suspension system. Can be raised or lowered by the boomhoist clutches. Also serves to raise counterweight into position or lower it to the ground.

### Gantry ball

Pinned to retractable high gantry ball links; serves as connection between gantry and boomhoist wire rope reeving. Contains four sheaves mounted on bronze bushings for 10-part boomhoist wire rope reeving.

### Counterweight

Removable and held in position by "T" bolts.

Counterweight "A" - 13,000 lbs. (5 897 kg)

Counterweight "AB" - 19,200 lbs. (8 709 kg)

**Note:** Refer to capacity charts for counterweight requirements.

**Counterweight removal device** - Power raising and lowering with boomhoist clutches.

## Crane booms and jibs

### ■ Angle boom

Two-piece basic boom 40' (12.19 m) long with open throat top section; 42" (1.07 m) wide, 42" (1.07 m) deep at connections. Alloy steel main chord angles; base section 4" x 4" x 5/16" (101.6 x 101.6 x 7.94 mm); top section and extensions - 4" x 4" x 5/16" (101.6 x 101.6 x 7.94 mm).

**Base section** - 20' (6.10 m) long; boom feet 1-5/8" (41.33 mm) wide on 38" (.97 m) centers.

**Boom extensions** - Available in 10' (3.05 m), 20' (6.10 m) and 30' (9.14 m) lengths with appropriate length pendants.

**Boom connections** - pin connections.

**Boom top section** - Open throat; 20' (6.10 m) long.

**Boompoint machinery** - Heat treated head sheaves, mounted on anti-friction bearings on boompeak shaft. Three 18" (.46 m) root diameter head sheaves.

### ■ Tube jib

Two-piece 20' (6.10 m) long; 30" (.76 m) wide, 24" (.61 m) deep at connections. Alloy steel tubular chords 1-1/2" (38.1 mm) diameter.

**Base section** - 10' (3.05 m) long.

**Jib extensions** - Available in 10' (3.05 m) lengths with appropriate length pendants.

**Jib connections** - In-line, tapered pin connections.

**Jib tip section** - 10' (3.05 m) long; single peak sheave 15-1/4" (.39m) root diameter mounted on anti-friction bearings.

### ■ Jib Mast

10' (3.05 m) high, mounted on jib base section. Two deflector sheaves mounted within mast to guide whipline; mounted on anti-friction bearings. Two equalizer sheaves mounted on top of mast - one for jib frontstay line, one for jib backstay line.

**Jib mast stops** - Telescoping type.

**Jib staylines** - Front and rear staylines vary in length depending on degree of jib offset from boom centerline; backstay lines attached at bottom end of boom top section.

**Boompoint sheave guards** - Standard; rigid, round steel rod bolted over top of sheaves and rigid, round steel rods between sheaves. *Optional*; roller-type guards mounted on anti-friction bearings, mounted on brackets beneath sheaves.

**Note:** Roller-type guards do not permit use of center sheave unless center guard is removed.

### ■ Boom stops

Standard; Dual tubular boom stops with spring loaded bumper ends; fixed horizontal on cab roof.

*Optional*; Dual tubular lever type backstops with spring loaded bumper ends.

### ■ Boomhoist bridle

Serves as connection between pendants and boomhoist reeving. Bridle contains four or five 9-1/2" (.24 m) root diameter sheaves, for 8 or 10-part boomhoist reeving.

**Deflector rollers** - Heat treated, tubular steel rollers mounted on anti-friction bearings. Deflect main drum load hoist line over top side of boom; also required when third drum load hoist line passes over top side of boom.

**Basic boom** - One roller standard on top section.

**Recommended:** *Optional rollers*; one per boom extension.

## Auxiliary equipment

### ■ Boom angle indicator

Standard; pendulum type, mounted on operator's side of boom base section.

### ■ Fairlead

*Optional*; full revolving type with barrel, sheaves and guide rollers mounted on anti-friction bearings.

### ■ Tagline

*Optional*; Rud-o-Matic model 648; spring wound drum-type.