



AT A GLANCE:

- Rated Capacity - 8,000 pounds
- Vertical Reach - 26 feet
- Horizontal Reach - 19 feet
- 360 Degree Rotation
- Carry Deck
- Hydraulic Outriggers

BMC BRODERSON
Manufacturing Corp.

P.O. Box 14770, Lenexa, KS 66285-4770
(913) 888-0606 • FAX (913) 541-0690

IC-35-1A

LOAD RADIUS FEET	MAIN BOOM CAPACITY IN POUNDS								
	360° ROTATION		OVER FRONT						
	ON RUBBER	ON OUTRIGGERS	ON RUBBER	ON OUTRIGGERS					
3	6000	7000	7000	8000					
4	5000	6000	6000	6000					
5	4500	4500	4500	4500					
6	3400	4350	4350	4350					
8	1950	3500	3500	3500					
10	1350	2900	2500	2900					
12	1000	2500	1900	2500					
14	800	2050	1550	2200					
16	650	1650	1250	1950					
17	600	1500	1150	1650					
18	550	1350	1100	1350					
20	450	1200	950	1200					
22	350	1050	800	1150					
24	300	900	700	1100					
25	200	800	600	1000					
BOOM ANGLE		0°	10°	20°	30°	40°	50°	60°	70°
CAPACITY		1050	1100	1150	1200	1300	1500	1900	2500

Capacities on outriggers are 85% of tipping loads. Capacities on rubber are 75% of tipping loads. Capacities below **BOLD** line are limited by tipping. Other capacities are limited by structural or hydraulic capabilities.
 Caution: Boom extension loads must not exceed main boom capacity.

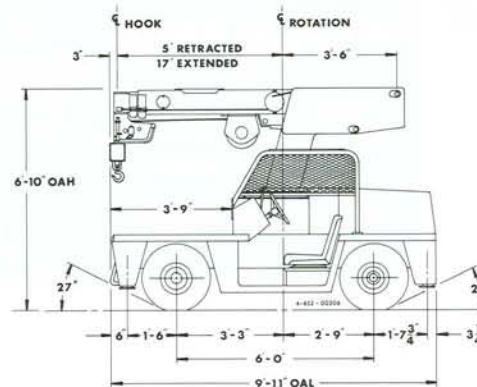
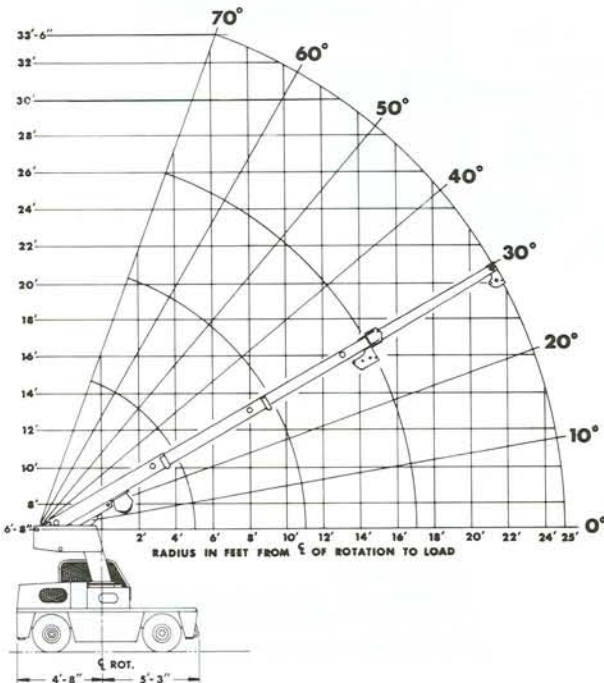
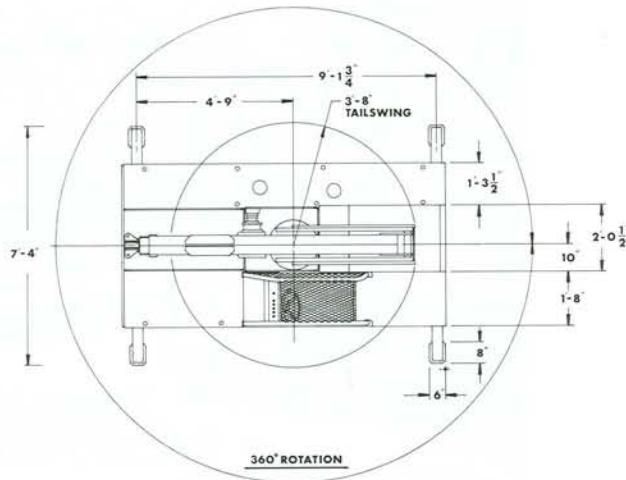
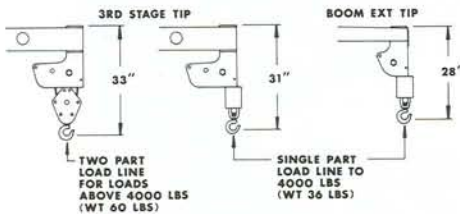
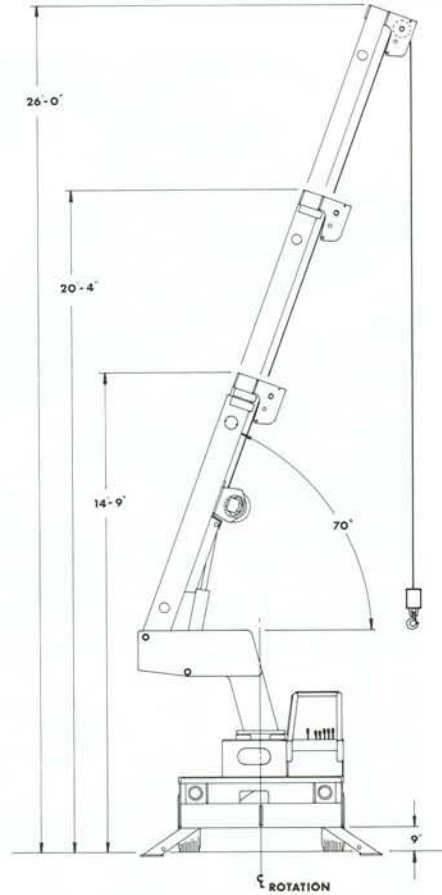

IC-35-2A

LOAD RADIUS FEET	MAIN BOOM CAPACITY IN POUNDS							
	360° ROTATION		OVER FRONT					
	ON RUBBER	ON OUTRIGGERS	ON RUBBER	ON OUTRIGGERS				
MAIN BOOM	4	5000	8000	6700	8000			
	5	4000	6800	5800	6800			
	6	2850	5850	5100	5850			
	8	1800	4150	3500	4150			
	10	1250	3200	2350	3400			
	12	900	2350	1750	2850			
	14	700	1850	1350	2450			
	16	600	1500	1100	2150			
	18	500	1250	950	1950			
	19	450	1150	900	1850			
8' BOOM EXTENSION	20	400	1100	850	1600			
	22	300	900	700	1450			
	24	250	800	600	1300			
	26	200	700	500	1150			
	27	150	650	450	1100			
	BOOM ANGLE	0°	10°	20°	30°	40°	50°	60°
CAPACITY	1100	1200	1300	1450	1600	1850	2300	3500

Capacities on outriggers are 85% of tipping loads. Capacities on rubber are 75% of tipping loads. Capacities below **BOLD** line are limited by tipping. Other capacities are limited by structural or hydraulic capabilities.
 Caution: Boom extension loads must not exceed main boom capacity.

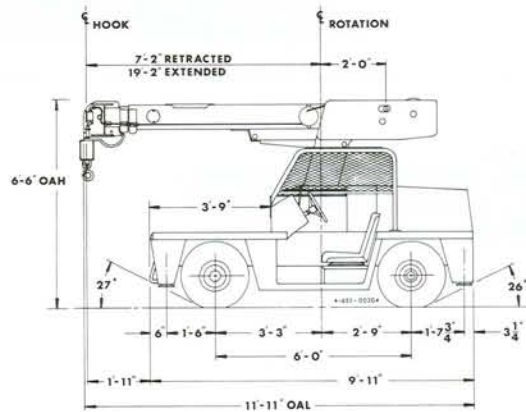
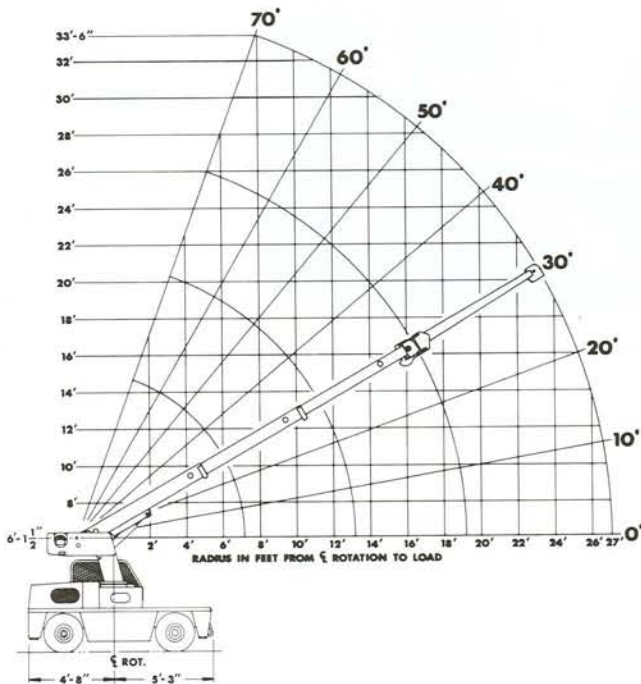
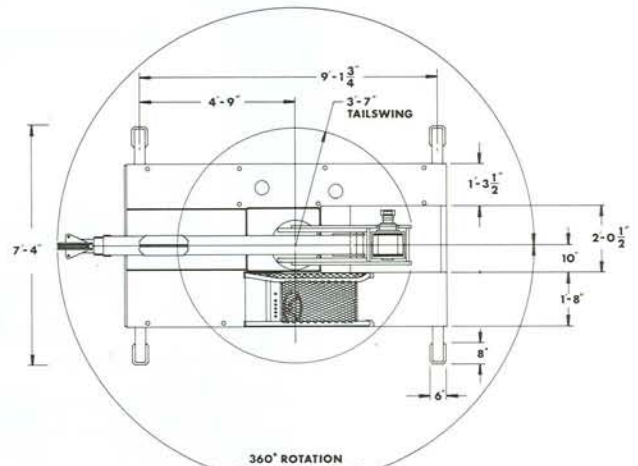
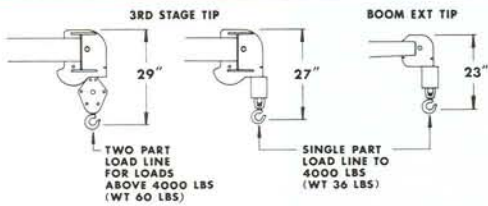
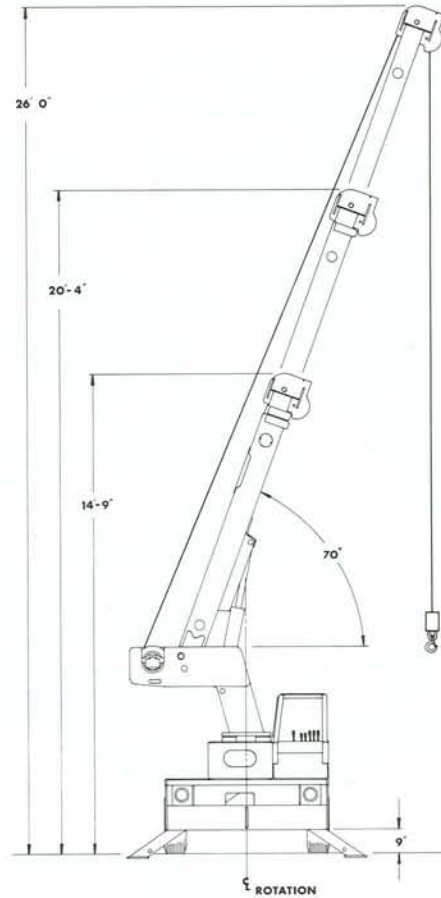

General:

Weight

- IC-35-1A - 7,500 pounds
- IC-35-2A - 7,100 pounds

Travel Speed - 0 to 10 MPH

Drawbar Pull - 2,300 pounds

Gradeability - 31% (17°)

Engine:

	Standard	Optional
Make	Ford	Perkins
Model	VSG413	104.19-IDI
No. of Cylinders	4	4
Displacement	79 CID	122 CID
HP @ Governed Speed	42 HP	42 HP

Fuel Tank Capacity - 13.5 Gallons

Electrical:

- **12 Volt System**
- **Lighting Group:**
1 pair headlights & 1 pair taillights
- **Instrument Group:**
Fuel, ammeter, oil pressure, water temperature, hydrostatic oil temperature gauges, hourmeter.
- **Back-Up Alarm:**
Provides pulsating sound when transmission is in reverse.

Hydrostatic Pump:

Piston type, driveline driven from engine crankshaft.
36 GPM @ 3,000 RPM engine. 4,000 PSI relief pressure.

Axles:

- **Front Drive Axle:**
Contains planetary geared torque hubs and high torque hydraulic drive motors. Axle oscillates a total of 1-1/2".
- **Rear Steering Axle:**
Non-oscillating.

Steering:

Full hydraulic orbitrol unit with one double-acting 2-1/2" cylinder attached to rear axle.

Tires:

7.50 x 10 pneumatic, 16-ply rating, front & rear

Brakes:

Front actuated disc service brake built into each torque hub. Overcenter park brake lever provided.

Outrigger:

Four hydraulic outriggers with box beam construction. Hydraulic cylinders are equipped with direct-connected holding valves.

Cargo Deck:

29 sq. ft. deck area, 6,000 pounds capacity over front axle.

Hydraulic System:

- Tandem pump mounted to rear of hydrostatic piston pump.
- Delivers 6 & 12 GPM at 3,000 RPM, 2,600 PSI relief pressure.
- Hydraulic oil tank has 14 gallons capacity.
- Hydraulic oil cooler provided.

Crane:

Boom Movement:

- Rotation 360° (Continuous Rotation, Optional)
- Elevation 0 to 70°
- Extension:
IC-35-1A 5' to 17'
IC-35-2A 7' to 19'

Boom Speeds:

- Rotation 360° in 26 seconds.
- Elevation 10 seconds.
- Extension 36 seconds.

Boom Assembly:

Three-section boom assembly equipped with bearing pads, double-acting hydraulic cylinders equipped with direct-connected holding valves and boom angle indicators on each side of boom.

Boom Rotation:

Heavy-duty ball bearing rotation gear with external teeth. Rotation is powered by hydraulic motor and worm gear drive.

Hydraulic Winch:

- Turret-mounted planetary winch.
- Hydraulic powered.
- Bare drum line pull of 4,600 lbs. (1st wrap)
- Winch line speed of 86 FPM. (1st wrap)
- 85 ft of 3/8" dia. 6 x 37 IWRC wire rope (B.S. 15,100 lbs.)
- Sheave Block provided for 2-part line.
- Downhaul weight provided for single-part line for loads to 4,000 lbs.

Anti-Two Block Device with Trip Arm:

Prevents damage to hoist rope and/or machine components. Dumps hydraulics for Telescope Out, Boom Down and Hoist Up.

IC-35-A

Listed below are brief descriptions of each option available for the IC-35-A Industrial Cranes.
Consult the IC-35-A Engineering Spec for additional information on each option.

1. IC-35-1A Industrial Crane with 5' to 17' Boom

2. IC-35-2A Industrial Crane with 7' to 19' Boom

ENGINE OPTIONS:

- 3. LP Gas System Kit**
Contains all necessary components for LP Gas.
- 4. Dual Fuel System Kit**
Contains all necessary components to burn LPG or gasoline.
- 5. Perkins Diesel Engine**
Perkins Model 104.19-IDI
- 6. Spark Arrester Muffler**
Installed in addition to standard muffler.
- 7. Engine Shutdown Gauges**
Shuts engine off when high water temperature or low engine oil pressure occurs.

TIRES:

- 8. Solid Rubber Tires**
For applications where hazardous ground conditions exist.
- 9. Foam Filled Tires**
Standard tires foam filled to prevent flats.
- 10. Spare Tire & Wheel**
7.50 x 10, 16-ply (front & rear wheels different)

CHASSIS:

- 11. Auxiliary Winch**
Mounted behind front bumper, hydraulically driven with control in operators console (3,000 lbs. @ 20 FPM)
- 12. Pintle Hook**
Holland "T-60-A" pintle hook mounted on rear of frame. (5-ton capacity)

- 13. Headlight & Taillight Grilles**
Welded steel protective grilles for headlights and taillights.
- 14. Lifting Rings**
Consists of four rings, one at each corner of the load deck.

OPERATOR COMPARTMENT:

- 15. Operator Guard**
Tubular steel weldment with heavy expanded steel mesh top section.
- 16. Operator Guard Cover**
Canvas cover with windows to go over Operator Guard, for inclement weather operations.
- 17. All Weather Cab**
Rigid-mounted canopy section & removable hinged door. Includes windshield wiper, heater and defroster fan. Cannot be used with Operator Guard.
- 18. Cab Enclosure**
Rigid-mounted canopy section with windshield wiper only. Does not include door, defroster fan or heater.
- 19. Floor Mat**
Vinyl mat with foam backing.

ELECTRICAL:

- 20. Outrigger Warning System**
Two-tone alarm is activated when "Outrigger Down" controls are operated
- 21. Strobe Lights**
Two yellow strobe lights mounted to turntable.
- 22. Lighted Instrument Gauges**
Instrument gauges equipped with lights for night operations.

- 23. Boom Work Lights**
One work light mounted to boom to light boom tip and one work light mounted to turret.

SWING OPTION:

- 24. Continuous Rotation**
Hydraulic swivel with four electric slip rings.

BOOM ATTACHMENTS:

- 25. Boom Extension**
8 foot, boom stowable.
- 26. Wire Rope - IC-35-2A Only**
140 ft. of 3/8" dia.
- 27. Load Moment Indicator**
Warns operator of impending overload with audible and visual signals. Prevents overload by stopping boom functions that cause overloads. Readouts for load, boom angle, boom length and load radius.
- 28. Load Indicator**
Three sheave load sensor on top of boom. Readout on top of instrument panel.

Should you, as an end user require an option or special equipment on your IC-35-A that is not listed on our sales literature, please contact your dealer salesperson or the factory to receive a special quoted price.



IC-35-A



IC-20



IC-200



IC-80

bmc BRODERSON
Manufacturing Corp.

P.O. Box 14770, Lenexa, KS 66285-4770
(913) 888-0606 • FAX (913) 541-0690