

General Specifications

Link-Belt® 60 ton (54.43 metric ton)

Wire rope crawler excavator/crane

LS-128DLC

GENERAL INFORMATION ONLY

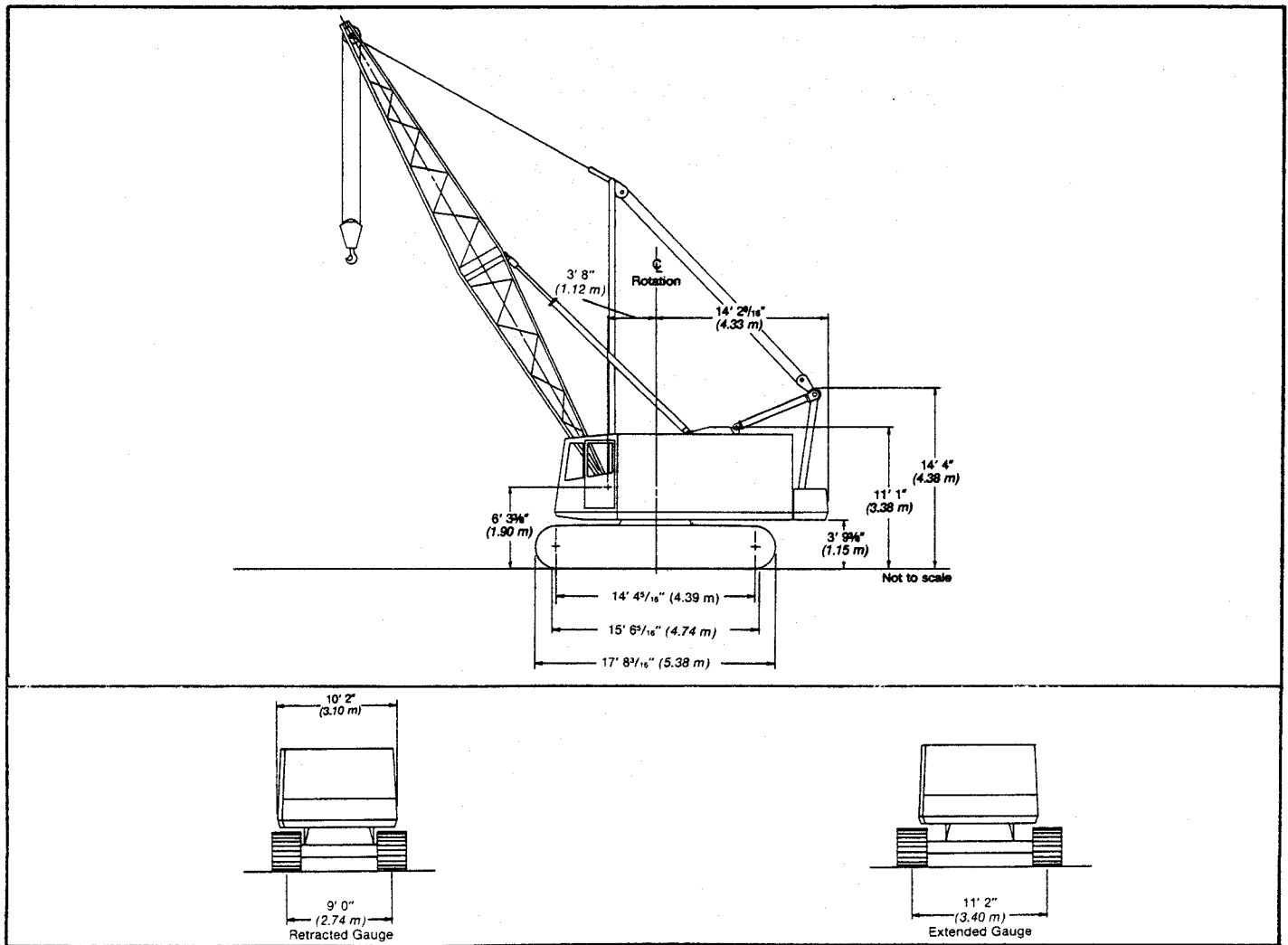

General dimensions	Feet	meters
Basic boom length, angle and tubular	40' 0"	12.19
Overall width side frames extended		
—30" (0.76 m) track shoes	13' 8"	4.16
—36" (0.91 m) track shoes	14' 2"	4.32
Overall width side frames retracted		
—30" (0.76 m) track shoes	11' 6"	3.50
—36" (0.91 m) track shoes	12' 0"	3.66
Minimum ground clearance	1' 2"	0.35
Ground clearance under counterweight "A"	3' 9 ³ / ₁₆ "	1.15

General dimensions	Feet	meters
Ground clearance under counterweight "AB"	3' 9 ³ / ₁₆ "	1.15
Overall width of counterweight	9' 10"	2.99
Tailswing of counterweight "A"	14' 2 ⁹ / ₁₆ "	4.33
Tailswing of counterweight "AB"	14' 2 ⁹ / ₁₆ "	4.33
Overall cab width less catwalks	10' 2"	3.10
Overall cab width with catwalks	13' 10 ³ / ₁₆ "	4.23
Overall height for transport, gantry lowered		
—Basic machine	11' 3 ³ / ₁₆ "	3.44
—Basic revolving upperstructure only	7' 5 ¹ / ₁₆ "	2.23

Weight deductions for transporting — approximate

1. Basic machine, less boom and counterweight:
 30" (0.76 m) track shoes — 78,704 lbs. (35 700 kg)
 36" (0.91 m) track shoes — 81,204 lbs. (36 834 kg)

Basic revolving upperstructure with turntable bearing, all dragline and boomhoist rope, gantry raising unit, less counterweight — 35,515 lbs. (16 110 kg)

2. Complete crawler mounting:
 30" (0.76 m) track shoes — 43,189 lbs. (19 591 kg)
 36" (0.91 m) track shoes — 45,689 lbs. (20 725 kg)

3. Carbody with machinery — 13,800 lbs. (6 260 kg)

4. Side frame (each):
 30" (0.76 m) track shoes — 14,695 lbs. (6 666 kg)
 36" (0.91 m) track shoes — 15,945 lbs. (7 233 kg)

5. Counterweight:
 "A" — 17,500 lbs. (7 938 kg)
 "AB" — 27,500 lbs. (12 474 kg)

6. Catwalks (pair) — 815 lbs. (370 kg)

7. Boom stops — 686 lbs. (311 kg)

8. Boomhoist bridle and spreader bar with basic pendants (machine without live mast) — 768 lbs. (348 kg)

9. Boom live mast with spreader bar, bridle, and basic pendants — 2,204 lbs. (1 000 kg)

10. Basic 40' (12.19 m) angle boom — 5,319 lbs. (2 413 kg)

Basic 40' (12.19 m) tubular boom — 3,565 lbs. (2 434 kg)

Fairlead — 1,382 lbs. (627 kg)

Tagline winder (single drum) — 325 lbs. (147 kg)

Tagline winder (dual drum) — 728 lbs. (330 kg)

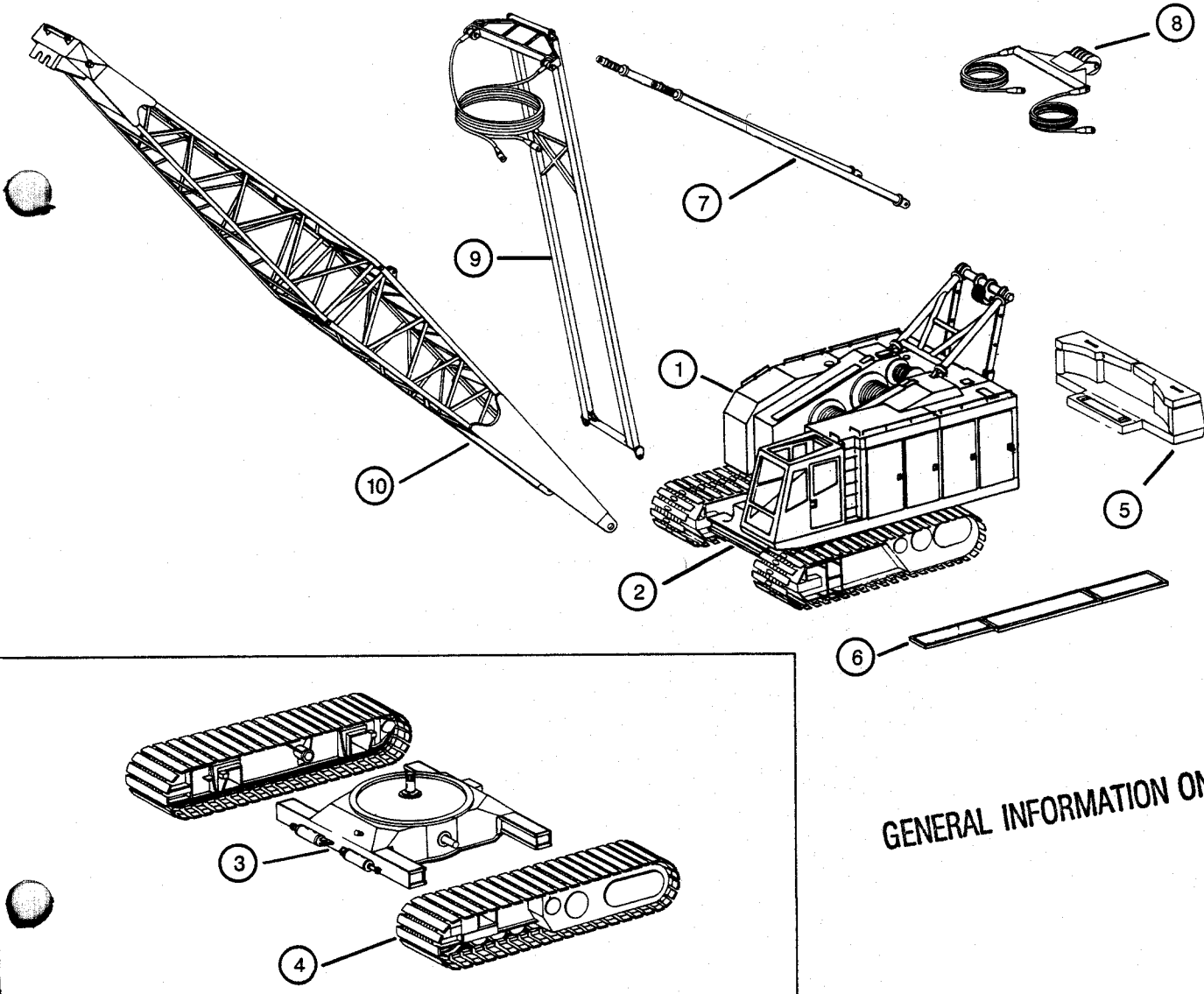

GENERAL INFORMATION ONLY

Machine working weights — approximate

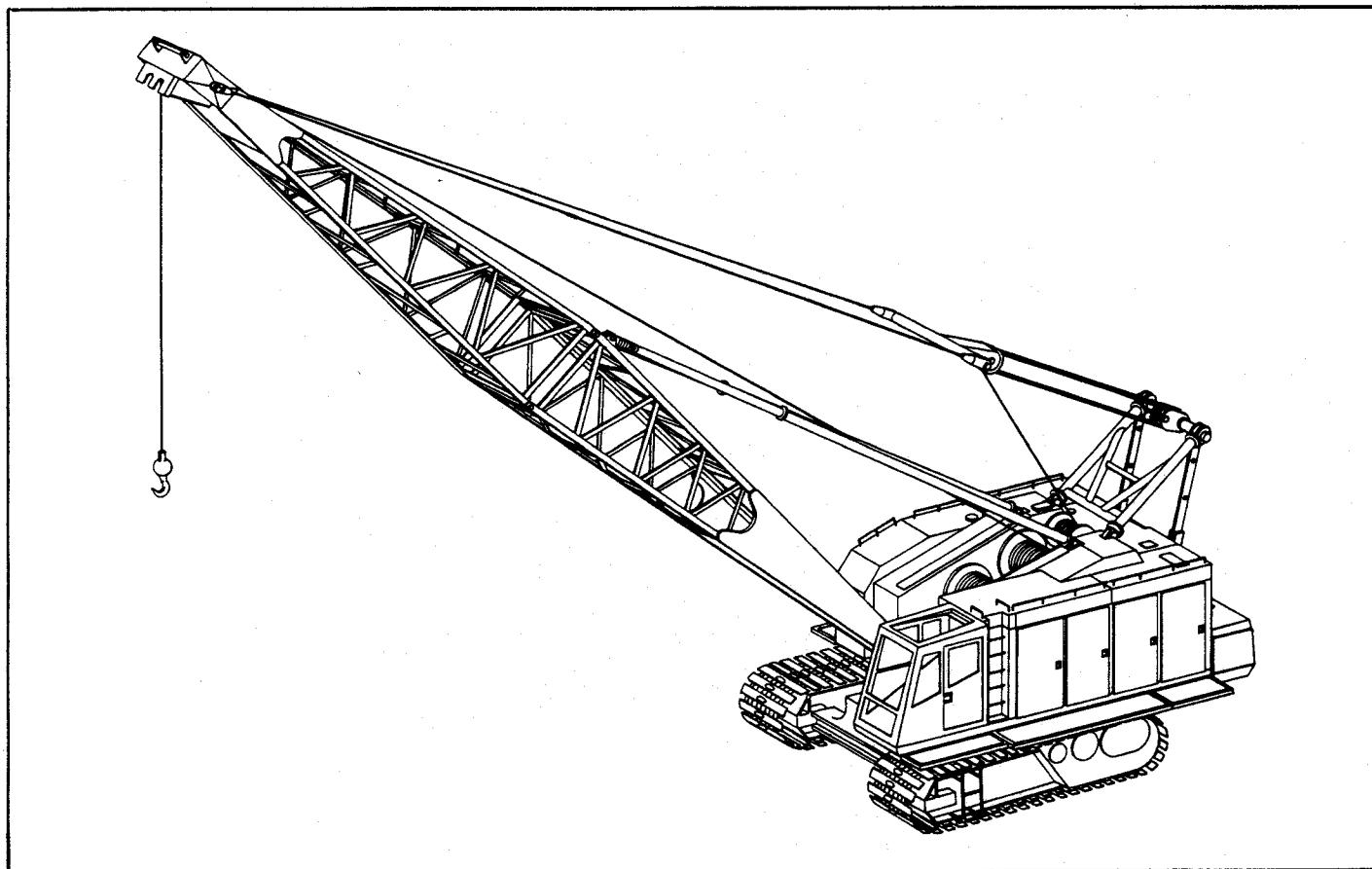

Complete basic machine with GM6-71N diesel engine and friction clutch, turntable bearing, independent swing and travel, swing brake, front and rear drum laggings with necessary hoist and inhaul lines, independent boomhoist with lowering clutch, 40' (12.19 m) angle boom, but not bucket or hook block:

17,500 lbs. (7 938 kg) counterweight "A"
27,500 lbs. (12 474 kg) counterweight "AB"

Track shoes

30" (0.76 m)		36" (0.91 m)	
Pounds	kilograms	Pounds	kilograms
102,987	46 715	105,487	47 849
112,987	51 251	115,487	52 384

General specifications

Mounting-crawler

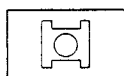

Lower frame

All-welded, stress relieved, precision machined; line bored for traction shaft. Machined surface provided for mounting turntable bearing.

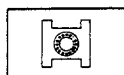

Turntable bearing

Outer race, with integral external swing gear, bolted to lower frame.

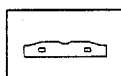

Crawler side frames

All welded, stress relieved, precision machined. Side frames removable; pin connected to cross axles and locked in position with extend/retract/locking cylinders. Four hydraulic cylinders (two on each end of lower frame) provide for extending, retracting and locking in position of LS-128DLC side frames.

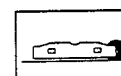

Track drive sprockets

Cast steel, heat treated, involute splined to shafts which are mounted on bronze bushings. Track/chain drive sprockets splined on shaft mounted on bronze bushings in crawler side frames; one assembly per side frame. Track drive chain enclosed and running in oil.

GENERAL INFORMATION ONLY

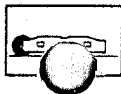

Track idler wheels

Cast steel, heat treated; mounted on bronze bushings. One track idler wheel per side frame.

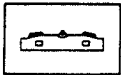

Track carrier slide rails

Tracks slide on rails; two rails on top of each side frame.

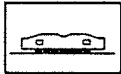

Track rollers

Heat treated, mounted on bronze bushings, ten rollers per side frame.

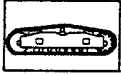

Tracks

Heat treated, self cleaning, multiple hinged track shoes joined by two-piece full floating pins: 50 shoes per side frame. Standard shoes 30" (0.76 m) wide; optional shoes 36" (0.91 m) wide.

Track/chain adjustment — Track adjusted with threaded adjusting bolts attached to track idler (wheel) axles. *Optional:* Portable hydraulic cylinders for track adjustment. Track drive chains adjusted by an adjustable take-up sprocket; track drive chain take-up assembly enclosed in track drive chaincase.



Independent travel

Permits simultaneous travel and swing with individual set of clutches for each function. Standard; Three-piece traction shaft joined with involute splined couplings; inner traction shaft mounted on bronze bushings in precision bored lower frame. Outer traction shaft engages splines in chain drive sprockets which are mounted on bronze bushings in side frames. Powered by bevel gear drive enclosed in oil within lower frame. *Optional:* two speed travel.

Travel speed — Standard single speed travel — .87 m.p.h. (1.40 km/h). *Optional* two speed travel — .87 m.p.h. (1.40 km/h) in low gear and 1.74 m.p.h. (2.80 km/h) high gear.

Gradeability — 30% permissible.

Steering — Power hydraulic. Travel/steer jaw clutches hydraulically engaged, spring released. Spring-applied hydraulically released travel/steer/digging/parking external contracting band brakes simultaneously released by interconnecting mechanical linkage to jaw clutches. Brakes automatically set when steer lever is in neutral. Two 20" (0.51 m) diameter by 4" (0.10 m) wide brake bands; effective lining area 186 square inches (1 200 cm²) per brake. Steer brakes also serve as parking/digging brakes.

Ground contact area and ground bearing pressure — based on machine equipped with 60' (18.29 m) angle boom

Counterweight	Track shoes		Ground contact area		Ground bearing pressure	
	Inches	meters	Sq. inches	m ²	P.s.i.	kPa
"A" — 17,500 lbs. (7 938 kg)	30	0.76	11,220	7.24	9.40	64.81
	36	0.91	13,500	8.71	8.00	55.16
"AB" — 27,500 lbs. (12 474 kg)	30	0.76	11,220	7.24	10.29	70.95
	36	0.91	13,500	8.71	8.74	60.26

Revolving upperstructure

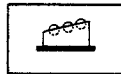

Frame

All-welded, stress relieved, precision machined; machinery side housings welded integral with frame.

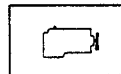

Engines

Full pressure lubrication, oil filter, oil cooler, air cleaner, fuel filter, hour meter, and hand throttle. *Optional* foot throttle available. Manual control shutdown for engine.

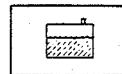

Fuel tank

75 gallon (284 L) capacity; equipped with fuel sight level gauge, flame arrester, and filler pipe cap with locking eye for padlock.



Turntable bearing

Inner race of bearing bolted to machined surface on under side of frame.

GENERAL INFORMATION ONLY

Engine specifications	GM6-71N with friction clutch	GM6-71N with single stage torque converter [Ⓞ]
Number of cylinders	6	6
Bore and stroke — inches — (mm)	4¼ x 5 (108 x 127)	4¼ x 5 (108 x 127)
Piston displacement — cubic inches — (cm ³)	426 (6 982)	426 (6 982)
High idle speed — r.p.m. Engine r.p.m. @ full load speed	1,950 1,800	1,430 1,225
Net engine h.p. @ full load speed Peak — ft. lbs. — (J)	148 (110 kW) 484 (656)	178 (133 kW) 532 (721)
Peak torque — r.p.m.	1,000	1,200
Electrical system Batteries	12-volt One 12-volt	12-volt One 12-volt
Clutch or power take-off	Friction clutch	Disconnect between engine and converter
Transmission — Number chain wheel teeth Number engine pinion teeth	96 19	96 27

Ⓞ Allison TC DOA-475 single stage torque converter.

Power train

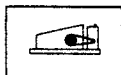

Transmission

Triple roller chain enclosed in oil tight chain case and running in oil. Drive chain tension adjusted by adjusting arm inside chain case.

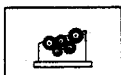

Machinery gear train

"Full-Function" design, two-directional power available to all operating shafts; shafts mounted on anti-friction bearings in precision bored machinery side housings. All load hoist, swing, travel, and boomhoist functions independent of one another. Components such as gears, pinions, chain wheels, brake drums and clutch spiders involute splined to shafts. Drum gear/clutch drum assemblies bolted together and mounted on shafts on anti-friction bearings. Machine-cut teeth on drum gears, pinions, spur gears, and chain wheel.

Principal operating functions



Control system

Speed-o-Matic[®] power hydraulic control system requiring no bleeding. Variable operating pressure transmitted to all 2-shoe clutch cylinders as required. System includes constant displacement, engine driven, gear type hydraulic pump to provide flow of oil, hydraulic oil reservoir, accumulator to maintain system operating pressure, unloader valve to limit maximum pressure buildup in

system, full-flow filter with 40 micron disposable filter element, and variable pressure control valves to control drum clutches and other operating cylinders.



Independent travel

Travel independent of all other functions standard; spur gear driven. Standard: single speed travel. Single bevel gear splined to horizontal travel shaft; single bevel gear splined to vertical travel shaft.

Clutches — Speed-o-Matic[®] power hydraulic 2-shoe clutches; internal expanding, lined shoes. One clutch each for forward and reverse. Clutch drum 20" (0.51 m) diameter, 5" (0.13 m) wide; effective lining area 215 square inches (1 387 cm²).

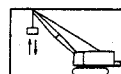

Load hoisting and lowering

Wire rope drum gear train (front and rear main, and optional third, operating drums) powered by chain transmission from engine.

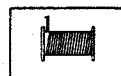

Load hoist drums

Front and rear main operating drums — Two-piece, removable, smooth or grooved laggings bolted to brake drum which is splined to drum shaft. Extended length shafts permit installation of optional power load lowering clutches for either or both drums. Special length shaft required for, and furnished with, optional planetary drive units for either or both drums.

— Dragline application: 17" (0.43 m) front and rear grooved drum laggings.
— Clamshell or magnet application: 17" (0.43 m) front and rear grooved drum laggings.
— Lifting crane operation: 14½" (0.38 m) front and rear smooth drum laggings.

Third operating drum — *Optional*; mounts forward of front main operating drum. Two-piece 15½" (0.38 m) root diameter smooth drum lagging bolted to brake drum. Brake drum splined to shaft.



Drum clutches

Speed-o-Matic[®] power hydraulic 2-shoe clutches; internal expanding, lined shoes. Clutch spiders splined to shafts; clutch drums bolted to drum spur gears and mounted on shafts on anti-friction bearings.

Load hoist clutches — Speed-o-Matic power hydraulic 2-shoe clutches; internal expanding, lined shoes. Front and rear main operating drums — clutch drums 26" (0.66 m) diameter, 6" (0.15 m) face width; effective lining area 356 square inches (2 297 cm²). Optional third operating drum — clutch drum 20" (0.51 m) diameter, 5" (0.13 m) face width; effective lining area 215 square inches (1 387 cm²).

Load lowering clutches — *Optional*: Speed-o-Matic power hydraulic 2-shoe clutches; internal expanding, lined shoes. Front and rear main operating drums and third operating drum — 20" (0.51 m) diameter, 5" (0.13 m) wide; effective lining area 215 square inches (1 387 cm²).

Drum planetary drive units — *Optional*; available for load hoist on either or both front and rear main operating drum to allow 70% increase of standard load hoist speed. Planetary units mount on extended drum shafts between drum spur gears and 2-shoe clutch drums. Two-shoe clutches control standard line speeds. Planetary drive units controlled by external contracting hand brakes through push button located on clutch control levers.

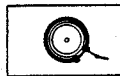

Drum brakes

Two-piece, external contracting band; brake drum involute splined to shaft. Mechanically foot pedal operated; foot pedal equipped with latch to permit locking brake in applied position.

Front and rear main drums — Brakes 38" (0.96 m) diameter, 5" (0.13 m) face width; effective lining area 473 square inches (3 052 cm²).

Optional third drum — Brake 22" (0.56 m) diameter, 4½" (0.11 m) face width; effective lining area 252 square inches (1 626 cm²).



Drum locking pawls

Optional for front and rear main, and optional third drums; spring applied hydraulically released. Pawl engages ratchet teeth integral with brake drum flange.

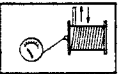

Drum rotation indicators

Optional for front and rear main operating drums. Two rotating dials mounted on control stand; dials actuated by flexible shaft drive from front or rear main operating drum.

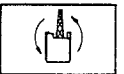

Swing system

Spur gear driven; single bevel gears (enclosed and running in oil) on horizontal and vertical swing shafts. Swing pinion involute splined to vertical swing shaft, meshes with external teeth of swing gear.



Swing clutches

Speed-o-Matic® power hydraulic 2-shoe clutches; internal expanding, lined shoes. Clutch drums 26" (0.66 m) diameter, 6" (0.15 m) wide; effective lining area 256 square inches (1 650 cm²).

Swing brake — External contracting band; spring applied, hydraulically released by operator controlled lever. Brake drum involute splined to vertical swing shaft. Brake 18" (0.46 m) diameter, 4" (0.10 m) face width; effective lining area 166 square inches (1 071 cm²).

Swing lock — Mechanically controlled pawl engages external teeth of turntable bearing swing gear.

Maximum swing speed — 3.14 r.p.m.

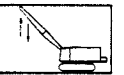

Boom hoist/lowering system

Independent, spur gear driven. Precision control boom hoisting and lowering through power hydraulic 2-shoe clutches.

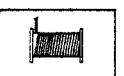

Boomhoist drum

Single grooved lagging splined to shaft; 12 5/8" (0.31 m) root diameter.

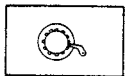

Boomhoist drum locking pawl

Operator controlled; mechanically applied and released.



Boom hoist/lowering clutches

Speed-o-Matic® power hydraulic 2-shoe clutches; internal expanding, lined shoes. One each for boom hoisting and boom lowering; clutch drum 20" (0.51 m) diameter, 5" (0.13 m) wide; effective lining area 215 square inches (1 387 cm²).

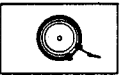

Boomhoist brake

One external contracting band brake; spring applied, hydraulically released. Brake drum involute splined to shaft. Brake 22" (0.56 m) diameter, 4 1/2" (0.12 m) face width; effective lining area 252 square inches (1 626 cm²).

Boomhoist limit device — Provided to restrict hoisting boom beyond recommended minimum radius; located on boom live mast support. Hydraulic control valve, contacted by boom as it approaches minimum radius, diverts Speed-o-Matic oil to reservoir, which disengages boom hoist clutch; as hydraulic pressure is shut off, boomhoist brake is spring applied.



Electrical system

Battery, one 12-volt, 225 ampere hour. Optional: battery lighting system, including two sealed beam automotive type adjustable headlights located on cab front roof, two interior cab lights and automotive type wiring.

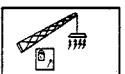

Magnet generator/control package

Optional: 27.5 kW magnet generator belt driven off engine power-take-off shaft. Generator for use with 230 volt magnets rated at 81 to 130 cold amperes. Rheostat, controller, magnet lift control button on rear drum control lever, drop control button on swing lever. Rud-o-Matic #648 combination tagline/magnet cable take up reel included. The generator is mounted on a bracket on rear of machine, above the counterweight; a raincover houses the generator for weather protection.



Operator's cab

Modular type cab with hinged door and safety glass panels. Standard equipment includes dry chemical fire extinguisher and bubble-type level. Optional: electric windshield wiper, cab heater, defroster fan and sound reduction material.

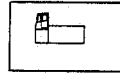

Elevated operator's cab

Optional: 4' (1.22 m) or 8' (2.44 m) higher elevation than standard cab.

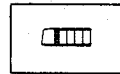

Machinery cab

Hinged doors on both sides and sliding doors at rear for machinery access. Equipped with warning horn roof-top access ladder, and skid resistant finish on roof.

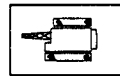

Catwalks

Optional for operator's side or both sides of cab. Serrated open steel grate construction.

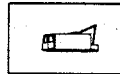

Gantry

Back hitch type, retractable; raised or lowered by hydraulic cylinder. Gantry pinned in raised working position or lowered traveling position.

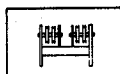

Gantry bail

Pivots on gantry headshaft; mounted on bushings. Contains 4 sheaves for 10-part boomhoist wire rope reeving, or 6 sheaves for 14-part boom hoist wire rope reeving. Sheaves 10 3/4" (0.27 m) root diameter; mounted on anti-friction bearings.

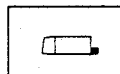

Counterweight

Removable; held in place by "eye" bolts. 17,500 lbs. (7 938 kg) counterweight "A" standard, 27,500 lbs. (12 474 kg) counterweight "AB" optional. Refer to counterweight instructions with lifting capacity chart.

Counterweight removal device — Optional: Double acting hydraulic cylinder lowers and raises counterweight. Cylinder is anchored to upper frame and cylinder rod end is anchored to the gantry.

GENERAL INFORMATION ONLY

Booms and jibs

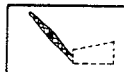

Angle boom

Two-piece, 40' (12.19 m) basic length; 48" (1.22 m) wide, 48" (1.22 m) deep at connections. Main chord angles high strength, low alloy steel, 4" x 4" x 3/8" (102 x 102 x 10 mm). Maximum boom length without boom live mast 100' (30.48 m); with boom live mast 140' (42.67 m).

Boom base section — 20' (6.10 m) long; boomfeet 2 3/8" (60 mm) wide on 54" (1.37 m) centers.

Boom extensions — Available in 10' (3.05 m), 20' (6.10 m) and 30' (9.14 m) lengths with appropriate length pendants.

Boom connections — In-line pin connected.

Boom top section — Open throat; 20' (6.10 m) long.

Boompnt machinery—Two or four sheaves available; two sheaves for combination dragline or clamshell service, four sheaves for lift crane application. Dragline/clamshell sheaves 22" (0.56 m) root diameter, lift crane sheaves 18" (0.46 m) root diameter.

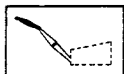

Angle jib

Two piece basic jib 20' (6.10 m) long; 24" (0.61 m) wide; 20" (0.51 m) deep at connections. Alloy steel main chord angles, 2 1/2" x 2 1/2" x 5/16" (64 x 64 x 8 mm).

Base section — 10' (3.05 m) long; mounted to bracket welded on end of boom top section.

Jib extensions — Available in 10' (3.05 m) and 15' (4.57 m) lengths; maximum jib length permitted — 40' (12.19 m).

Jib connections — Bolted.

Jib tip section — 10' (3.05 m) long; single peak sheave 15 3/8" (4.57 m) root diameter, mounted on anti-friction bearings.



Jib mast

10' (3.05 m) high, mounted on jib base section. On deflector sheave mounted within mast to guide jib load hoist line. Two equalizer sheaves mounted on top of mast — one for jib frontstay line, one for jib backstay line.

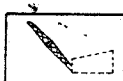

Tubular boom

Two-piece, 40' (12.19 m) basic length; 54" (1.37 m) wide, 44" (1.12 m) deep at centerline of connections. Alloy steel round tubular main chords 3" (76 mm) outside diameter. Maximum boom length 170' (51.82 m) with live mast, 120' (36.58 m) without live mast.

Boom base section — 20' (6.10 m) long; boomfeet 2 3/8" (60 mm) wide on 54" (1.37 m) centers.

Boom extensions — Available in 10' (3.05 m), 20' (6.10 m) and 30' (9.14 m) lengths with appropriate length pendants.

Boom connections — In-line pin connected.

Boom top section — Open throat; 20' (6.10 m) long.

Boompnt machinery — four 18" (0.46 m) root diameter head sheaves mounted on anti-friction bearings.

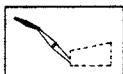

Tubular jib

Two-piece basic jib 20' (6.10 m) long; 30" (0.76 m) wide, 24" (0.61 m) deep at connections. Main tubular chords alloy steel, 1 1/2" (38 mm) outside diameter.

Base section — 10' (3.05 m) long; mounted to bracket on top section of boom.

Jib extensions — Available in 10' (3.05 m) lengths.

Jib connections — In-line pin connected.

Jib tip section — 10' (3.05 m) long; equipped with 15 1/4" (0.39 m) root diameter sheave mounted on anti-friction bearings.



Jib mast

10' (3.05 m) high, mounted on jib base section. Two deflector sheaves, mounted on anti-friction bearings, mounted within mast to guide whipline. Two equalizer sheaves mounted on top of mast — one for jib frontstay line, one for jib backstay line.

Items applicable to both booms and jibs



Boom stops

Dual telescoping, pinned to both boom base section and upper frame. Required for all boom lengths and when using boom live mast as short boom. Designed per California and Corps of Engineers code requirements.

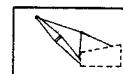

Boom live mast

Optional; reduces boom compression loadings. Welded tube/plate construction; 23' (7.01 m) long from center of bridge connection shaft to mounting pin. Supports boomhoist bridle; mast may also be used for machine assembly or disassembly, but is not intended for general crane service. Required for all tubular boom lengths over 130' (39.62 m) without jib, and for all tubular boom lengths when jib is used. Required for all angle boom lengths over 100' (30.48 m) without jib, and for all angle boom lengths over 60' (18.29 m) when jib is used.

Live mast stops — When using mast as short boom, main boom stops must be pinned to boom live mast.

Auxiliary load hoist sheaves — Two 6 1/2" (0.15 m) root diameter sheaves, grooved for 3/4" (19 mm) or 7/8" (22 mm) diameter wire rope, mounted on bronze bushings; for use of live mast as a short boom.

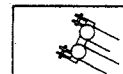

Boomhoist bridle

Serves as connection between boom pendants and boomhoist reeving. Contains five sheaves for ten-part boomhoist reeving (without live mast) or seven sheaves for fourteen-part boomhoist reeving (with or without live mast). Sheaves 10 3/4" (0.27 m) root diameter, mounted on anti-friction bearings.

Spreader bar — All welded high strength bar and plate construction; mounts to boom live mast head shaft or welded integral with bridle when machine not equipped with live mast. Spreads pendants for clearance with hoist ropes. Required on all boom lengths.

Boompnt sheave guards — Standard for dragline/clamshell/crane service. Upper sheave guard: Single adjustable guard of plate and pipe construction, bolted over top of sheaves. Lower sheave guards: Welded round bar and plate construction; available for three sheave boompnt machinery. Lower sheave guards available with 18" (0.46 m) sheaves for lift crane service only.

Deflector rollers — Used to deflect main hoist lines over top of boom; rollers 3" (76 mm) dia. heat treated, mounted in anti-friction bearings. **Angle boom:** One roller standard on boom top section; one additional roller required for boom lengths 90' (27.43 m) through 100' (30.48 m). **Tubular boom:** One roller standard on boom top section; one additional roller required for each boom extension.

Wear blocks — Used to protect top of boom from wire rope scrub; 3" x 6" x 45" (0.08 x 0.15 x 1.14 m) native hardwood. **Angle boom:** One wear block standard on each of first two boom extensions. **Tubular boom:** One wear block standard on boom top section; wear blocks for boom extensions provided as required.

Jib mast stops — Telescoping type; pinned from jib mast to boom top section and from mast to jib base section.

Jib staylines — Back staylines attached between top of jib mast and base of boom top section on tubular boom. Back staylines attached to boom base section on angle boom. Front staylines attached between top of jib mast and peak of jib.

Boom carrying equipment — For carrying angle or tubular boom, with boom live mast, in horizontal position at approximate 13' (3.96 m) overall clearance height. May be used with tubular booms 40' (12.19 m) through 120' (36.58 m) or angle booms 40' (12.19 m) through 100' (30.48 m). Boom suspension system uses a free link pinned at each end of an 8' 4" (2.54 m) pendant to make up standard boom pendant length. The free ends of the two links are pinned together, shortening boom pendant length and thus reducing overall height. Boom must not be used to handle loads with reduced mast height.

— With live mast; 20' (6.10 m) angle or tubular boom base section only may be carried with links pinned to live mast and lower boom stop casting shaft. — Without live mast; 20' (6.10 m) angle or tubular boom base section only may be carried with special links that pin to spreader bar/bridle and lower boom stop casting shaft.

— Without live mast; 20' (6.10 m) angle or tubular boom base section only may be carried with special links that pin to spreader bar/bridle and lower boom stop casting shaft.

Auxiliary equipment



Boom angle indicator

Standard with either crane boom. Pendulum type, mounted on boom base section.

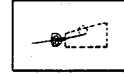

Fairlead

Optional. Full revolving type with barrel, sheaves, and guide rollers mounted on anti-friction bearings.

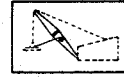

Tagline

Optional. Spring wound drum type mounted on crane boom.

- Dual drum; Rud-o-Matic® model 1248.
- Single drum; Rud-o-Matic® model 648.

GENERAL INFORMATION ONLY



We are constantly improving our products and therefore reserve the right to change designs and specifications.

FMC Corporation Construction Equipment Group Cedar Rapids Iowa 52406

Link-Belt® cranes & excavators manufactured in: Cedar Rapids Iowa • Lexington & Bowling Green Kentucky • Ontario Canada • Milan Italy • Queretaro Mexico & Nagoya Japan (under license)

Link-Belt® LS-128DL/DLC Performance Specifications

Boom live mast — Lifting capacities when used as short boom^①

Boom live mast radius ^②		Capacities with or without counterweight			
		LS-128DL		LS-128DLC ^③	
Feet	meters	Pounds	kilograms	Pounds	kilograms
10	3.05	47,000*	21 319*	47,000*	21 319*
12	3.66	40,000	18 144	45,000*	20 412*
15	4.57	29,000	13 154	40,000*	18 144*
20	6.10	19,000	8 618	27,000	12 247
25	7.62	14,000	6 350	19,000	8 618

*Based on factors other than those which would cause a tipping condition.

①Requires 4 parts of ¾" (22 mm) Type "N" wire rope. Boom live mast stops must be in proper working condition and operative. Use of live mast as short boom is intended for machine assembly or disassembly only. It should not be used for general crane service.

②Live mast must not be operated at radius less than 10' (3.05 m)

③Side frames must be in extended position.

Wire rope and drum data

Dragline or clamshell wire rope lengths — using 1 part wire rope

Attachment	Function	Boom lengths									
		40' (12.19 m)		50' (15.24 m)		60' (18.29 m)		70' (21.34 m)		80' (24.38 m)	
		Feet	meters	Feet	meters	Feet	meters	Feet	meters	Feet	meters
Dragline	Hoist	110	33.53	130	39.62	150	45.72	170	51.82	190	57.91
	Inhaul	50	15.24	60	18.29	70	21.34	80	24.38	90	27.43
Clamshell	Holding	110	33.53	130	39.62	150	45.72	170	51.82	190	57.91
	Closing	160	48.77	180	54.86	200	60.96	220	67.06	240	73.15

Main load hoist wire rope length — for angle and tubular booms^①, using ¾" (19 mm) wire rope

Parts of line	Boom lengths													
	40' (12.19 m)		50' (15.24 m)		60' (18.29 m)		70' (21.34 m)		80' (24.38 m)		90' (27.43 m)		100' (30.48 m)	
	Feet	meters	Feet	meters	Feet	meters	Feet	Meters	Feet	meters	Feet	meters	Feet	meters
1	100	30.48	120	36.58	140	42.67	160	48.77	180	54.86	200	60.96	220	67.06
2	150	45.72	180	54.86	210	64.01	240	73.15	270	82.30	300	91.44	330	100.58
3	200	60.96	240	73.15	280	85.34	320	97.54	360	109.73	400	121.92	440	134.11
4	250	76.20	300	91.44	350	106.68	400	121.92	450	137.16	500	152.40	550	167.64
5	300	91.44	360	109.73	420	128.02	480	146.30	540	164.59	600	182.88	660	201.17
6	350	106.68	420	128.02	490	149.35	560	170.69	630	192.02	700	213.36	770	234.70

Parts of line	Boom lengths													
	110' (33.53 m)		120' (36.58 m)		130' (39.62 m)		140' (42.67 m)		150' (45.72 m)		160' (48.77 m)		170' (51.82 m)	
	Feet	meters	Feet	meters	Feet	meters	Feet	Meters	Feet	meters	Feet	meters	Feet	meters
1	240	73.15	260	79.25	280	85.34	300	91.44	320	97.54	340	103.63	360	109.73
2	360	109.73	390	118.87	420	128.02	450	137.16	480	146.30	510	155.45	540	164.59
3	480	146.30	520	158.50	560	170.69	600	182.88	640	195.07	680	207.26	720	219.46
4	600	182.88	650	198.12	700	213.36	750	228.60	800	243.84	850	259.08	900	274.32
5	720	219.46	780	237.74	840	256.03	900	274.32	960	292.60	1,020	310.90	1,080	329.18
6	840	256.03	910	277.37	980	298.70	1,050	320.04	1,120	341.38	1,190	362.71	1,260	384.05

①Maximum angle boom length is 100' (30.48 m) for LS-128DL and 140' (42.67 m) for LS-128DLC; maximum tubular boom length is 150' (45.72 m) for LS-128DL and 170' (51.82 m) for LS-128DLC.

LS-128DL/DLC performance specifications

Wire rope and drum data — (continued)

Jib load hoist wire rope lengths (whipline) — for angle and tubular jibs, using 7/8" (22 mm) diameter wire rope for angle jib and 3/4" (19 mm) diameter wire rope for tubular jib

Jib length	Parts of line	Boom length [Ⓛ]											
		40' (12.19 m)		50' (15.24 m)		60' (18.29 m)		70' (21.34 m)		80' (24.38 m)		90' (27.43 m)	
		Feet	meters	Feet	meters	Feet	meters	Feet	meters	Feet	meters	Feet	meters
20' (6.10 m)	1	140	42.67	160	48.77	180	54.86	200	60.96	220	67.05	240	73.15
	2	205	62.48	235	71.63	265	80.77	295	89.92	325	99.06	355	108.20
30' (9.14 m)	1	160	48.77	180	54.86	200	60.96	220	67.05	240	73.15	260	79.24
	2	235	71.63	265	80.77	295	89.92	325	99.06	355	108.20	385	117.35
40' (12.19 m)	1	180	54.86	200	60.96	220	67.05	240	73.15	260	79.24	280	85.34
	2	265	80.77	295	89.92	325	99.06	355	108.20	385	117.35	415	126.49
50' [Ⓢ] (15.24 m)	1	200	60.96	220	67.05	240	73.15	260	79.24	280	85.34	300	91.44
	2	295	89.92	325	99.06	355	108.20	385	117.35	415	126.49	445	135.64

Jib length	Parts of line	Boom length [Ⓛ]											
		100' (30.48 m)		110' (33.53 m)		120' (36.58 m)		130' (39.63 m)		140' (42.67 m)		150' (45.72 m)	
		Feet	meters	Feet	meters	Feet	meters	Feet	meters	Feet	meters	Feet	meters
20' (6.10 m)	1	260	79.24	280	85.34	300	91.44	320	97.53	340	103.63	360	109.73
	2	385	117.35	415	126.49	445	135.64	475	144.78	505	153.92	535	163.07
30' (9.14 m)	1	280	85.34	300	91.44	320	97.53	340	103.63	360	109.73	380	115.82
	2	415	126.49	445	135.64	475	144.78	505	153.92	535	163.07	565	172.21
40' (12.19 m)	1	300	91.44	320	97.53	340	103.63	360	109.73	380	115.82	400	121.92
	2	445	135.64	475	144.78	505	153.92	535	163.07	565	172.21	595	181.36
50' [Ⓢ] (15.24 m)	1	320	97.53	340	103.63	360	109.73	380	115.82	400	121.92	420	128.02
	2	475	144.78	505	153.92	535	163.07	565	172.21	595	181.36	625	190.50

[Ⓛ]LS-128DL with angle boom plus jib, maximum boom length 60' (18.29 m); LS-128DL with tubular boom plus jib, maximum boom length 120' (36.58 m); LS-128DLC with angle boom plus jib, maximum boom length 120' (36.58 m); LS-128DLC with tubular boom plus jib, maximum boom length 150' (45.72 m).

[Ⓢ]Tubular jib only.

Boomhoist wire rope lengths — using 5/8" (16 mm) diameter wire rope

Boom	Without boom live mast				With boom live mast	
	10-part reeving		14-part reeving		14-part reeving	
	Feet	meters	Feet	meters	Feet	meters
Angle	360	109.73	490	149.35	550 [Ⓢ]	167.64
Tubular	360	109.73	490	149.35	550	167.64

[Ⓢ]LS-128DLC only.

Drum wire rope capacities

Wire rope layer	Boomhoist drum — 12 5/8" (0.31 m) root diameter grooved lagging				Third drum — 15 1/2" (0.38 m) root diameter smooth lagging			
	5/8" (16 mm) wire rope							
	Rope per layer		Total wire rope		Rope per layer		Total wire rope	
	Feet	meters	Feet	meters	Feet	meters	Feet	meters
1	76	23.16	76	23.16	103	31.39	103	31.39
2	91	27.73	167	50.90	121	36.88	224	68.27
3	98	29.87	265	80.77	132	40.23	356	108.50
4	107	32.61	372	113.38	142	43.28	498	151.79
5	114	34.74	486	148.13	153	46.64	651	198.42
6	122	37.18	608	185.31	163	49.68	814	248.10
7	130	39.62	738	224.94				

LS-128DL/DLC performance specifications

Wire rope and drum data — (continued)

Drum wire rope capacities — (continued)

Wire rope layer	Front or rear drum — 14 7/8" (0.38 m) root diameter smooth lagging								Front or rear drum — 17" (0.43 m) root diameter grooved lagging			
	3/4" (19 mm) wire rope				7/8" (22 mm) wire rope				1" (25 mm) wire rope			
	Rope per layer		Total wire rope		Rope per layer		Total wire rope		Rope per layer		Total wire rope	
	Feet	meters	Feet	meters	Feet	meters	Feet	meters	Feet	meters	Feet	meters
1	101	30.78	101	30.78	86	26.21	86	26.21	85	25.91	85	25.91
2	120	36.58	221	67.36	105	32.00	191	58.21	105	32.00	190	57.91
3	130	39.62	351	106.98	115	35.05	306	93.26	115	35.05	305	92.96
4	140	42.67	491	149.65	126	38.40	432	131.67	126	38.40	431	131.36
5	151	46.02	642	195.68	136	41.45	568	173.12	136	41.45	567	172.82
6	161	49.07	803	244.75	147	44.80	715	217.93	147	44.80	714	217.62
7	172	52.42	975	297.18	157	47.85	872	265.78				
8	182	55.47	1,157	352.65	168	51.20	1,040	316.99				
9	193	58.83	1,350	411.48	178	54.25	1,218	371.24				
10	203	61.87	1,553	473.35								

Rope size and type

Wire rope application	Wire rope types
Boomhoist	5/8" (16 mm) diameter, Type "W"
Main load hoist	3/4" (19 mm) diameter, Type "N"
Angle jib load hoist (1-part)	7/8" (22 mm) diameter, Type "P"
Angle jib load hoist (2-part)	7/8" (22 mm) diameter, Type "N"
Tubular jib load hoist (1-part)	3/4" (19 mm) diameter, Type "P"
Tubular jib load hoist (2-part)	3/4" (19 mm) diameter, Type "N"
Third drum	3/4" (19 mm) diameter, Type "N"
Clamshell holding or closing	
— angle boom	1" (25 mm) diameter, Type "M"
— tubular boom	7/8" (22 mm) diameter, Type "M"
Dragline hoist	
— angle boom	1" (25 mm) diameter, Type "M"
— tubular boom	7/8" (22 mm) diameter, Type "M"
Dragline inhaul — angle or tubular boom	1" (25 mm) diameter, Type "T"
Boom pendants — without live mast	1 1/8" (29 mm) diameter, Type "N"
Boom pendants — boom with live mast	1 1/4" (32 mm) diameter, Type "N"
Jib frontstay line	3/4" (19 mm) diameter, Type "N"
Jib backstay line	3/4" (19 mm) diameter, Type "N"

Wire rope types
Type "M" — 6 x 25 (6 x 19 class), filler wire, extra improved plow steel, preformed, independent wire rope center, right lay, lang lay.
Type "N" — 6 x 25 (6 x 19 class), filler wire, extra improved plow steel, preformed, independent wire rope center, right lay, regular lay.
Type "P" — 19 x 7 non-rotating, extra improved plow steel, preformed, wire strand core.
Type "T" — 6 x 30 flattened strand, extra improved plow steel, preformed, independent wire rope center, right lay, lang lay.
Type "W" — 6 x 26 (6 x 19 class), extra improved plow steel, preformed, independent wire rope center, right lay, alternate lay.

Available line speed and line pull^① — based on GM6-71N diesel engine with friction clutch^② developing maximum net horsepower as defined by P.C.S.A. Standard No. 1

Attachment	Front or rear drum								Third drum					
	Root diameter	Wire rope diameter		Line speed— first layer		Line pull— first layer		Root diameter	Wire rope diameter		Line speed— first layer		Line pull— first layer	
		Inches	mm	F.p.m.	m/min	Pounds	kilograms		Inches	mm	F.p.m.	m/min	Pounds	kilograms
Crane	14 7/8" (0.38 m)	3/4"	19	140	42.67	30,000	13 608	15 1/8" (0.38 m)	3/4"	19	190	57.91	20,800	9 435
		7/8"	22	142	43.28	29,700	13 472							
Clamshell or dragline	17" (0.43 m)	1"	25	162	49.38	26,000	11 794							

① ② Refer to notes following permissible line speed and line pull chart on page 4.



LS-128DL/DLC performance specifications

Wire rope and drum data

Permissible line speed and line pull^{①②} — based on wire rope strength, single part line

Attachment	Front or rear drum							Third drum						
	Root diameter	Wire rope diameter		Line speed— first layer		Line pull— first layer		Root diameter	Wire rope diameter		Line speed— first layer		Line pull— first layer	
		Inches	mm	F.p.m.	m/min	Pounds	kilograms		Inches	mm	F.p.m.	m/min	Pounds	kilograms
Crane	1 7/8" (0.38 m)	3/4"	19	140	42.67	16,800	7 620	1 5/8" (0.38 m)	3/4"	19	190	57.91	16,800	7 620
Clamshell or dragline	1 7/8" (0.43 m)	1 1/8"	25	162	49.38	26,000*	11 794*							

*Limited by engine capabilities.

① Available line pull is not based on wire rope strength. Maximum permissible load on single part of line — 16,800 lbs. (7 620 kg) for 3/4" (19 mm) diameter Type "N" wire rope; 22,700 lbs. (10 297 kg) for 7/8" (22 mm) Type "M" or "N" wire rope; 29,500 lbs. (13 381 kg) for 1" (25 mm) Type "M" wire rope; 10,800 lbs. (4 899 kg) for 3/4" (19 mm) Type "P" wire rope; 18,500 lbs. (8 392 kg) for 7/8" (22 mm) diameter Type "P" wire rope; 31,000 lbs. (14 062 kg) for 1" (25 mm) diameter Type "T" wire rope.

② Data applicable only to GM6-71N/friction clutch. To obtain net line speed/pull data for optional engines use the multiplication factors below. Note: Should net line pull differ from permissible line pull figure based on wire rope strength, the lower figure will apply.

Engine

GM6-71N with Allison single stage torque converter

GM6-71N with Allison single stage torque converter and auxiliary governor control

Line speed

.992

1.488

Line pull

.994

.571

③ Tubular boom uses 7/8" (22 mm) Type "M" wire rope on Clamshell holding and closing, and dragline hoist.

Load hoisting performance^① — line speeds are maximum for full throttle operation (1,882 r.p.m. full load speed) with GM6-71N diesel engine equipped with Allison single stage torque converter and optional auxiliary governor control.

Front or rear drum — 1 7/8" (0.38 m) root diameter smooth lagging using 7/8" (22 mm) wire rope													
Line speed													
Single line load ^②		First layer rope				Fourth layer rope				Eighth layer rope			
		Standard		High speed ^③		Standard		High speed ^③		Standard		High speed ^③	
Pounds	kilograms	F.p.m.	m/min.	F.p.m.	m/min.	F.p.m.	m/min.	F.p.m.	m/min.	F.p.m.	m/min.	F.p.m.	m/min.
5,000	2 268	236	71.93	401	122.22	314	95.70	509	155.14	420	128.02	662	201.78
10,000	4 536	235	71.63	346	105.46	281	85.65	389	118.57	365	111.25	381	116.13
15,000	6 804	211	64.31	252	76.80	258	78.64	245	74.68	286	87.17	180	54.86
20,000	9 072	196	59.74	178	54.25	220	67.06	140	42.67	192	58.52		
22,700	10 297	186	56.69	148	45.11	184	56.08			154	46.94		

Third drum — 1 5/8" (0.38 m) root diameter smooth lagging using 3/4" (19 mm) wire rope									
Line speed									
Single line load ^②		First layer rope			Third layer rope			Fifth layer rope	
		F.p.m.	m/min.	F.p.m.	m/min.	F.p.m.	m/min.	F.p.m.	m/min.
Pounds	kilograms	F.p.m.	m/min.	F.p.m.	m/min.	F.p.m.	m/min.	F.p.m.	m/min.
5,000	2 268	317	96.62	377	114.91	437	133.20		
10,000	4 536	298	90.83	337	102.72	368	112.17		
15,000	6 804	258	78.64	271	82.60	264	80.47		
16,800	7 620	238	72.54	244	74.37	201	61.26		

① Data applicable only to GM6-71N diesel engine as described above. If required, similar data for other engine packages available from Sales Office.

② Maximum permissible load on single part of line: 22,700 lbs. (10 297 kg) for 7/8" (22 mm) diameter Type "N" wire rope; 18,500 lbs. (8 392 kg) for 7/8" (22 mm) diameter Type "P" wire rope; 16,800 lbs. (7 620 kg) for 3/4" (19 mm) Type "N" wire rope; 10,800 lbs. (4 899 kg) for 3/4" (19 mm) Type "P" wire rope.

③ Machine equipped with optional high speed planetary drive units.

We are constantly improving our products and therefore reserve the right to change designs and specifications.



FMC Corporation Cable Crane & Excavator Division Cedar Rapids, Iowa 52406

Link-Belt® cranes & excavators manufactured in: Cedar Rapids Iowa • Lexington & Bowling Green Kentucky • Ontario Canada • Milan Italy • Queretaro Mexico & Nagoya Japan (under license)