

features

- 4-Section 124' (37,8 m) or 102' (31,1 m) Proportional boom
- 135' (41,2 m) Maximum main boom tip height
- Custom boom point adapter for auxiliary hoist operations
- 22' 4" (6,8 m) A-frame link type pedestal outriggers
- 19' 10" (6,1 m) Behind the cab front out-down type outriggers
- Single rear stabilizer
- 2-Speed Planetary Main hoist with grooved drum and negative draft angle
- Single speed auxiliary planetary hoist
- Load moment indicator with digital display, CAN bus, overload shutdown and internal boom length cable
- Radio Anti-two-block system for both Main and Aux hoist lines
- Rugged, weatherproof electrical system with circuit status LEDs
- Removable boom rest
- 21' (6,4 m) clear deck space
- System pressure gauge
- Clamp-on mounting
- SAE O-ring and O-ring face seal adapters
- Manitex UPTIME comprehensive support



series WL

GENERAL SPECIFICATIONS

BOOM

Booms - Inverted T-cross section, 4-section telescoping type, extended and retracted proportionally by a double-acting hydraulic cylinder and cable-crowd system. Easily replaceable and adjustable teflon-plugged high density nylon slider pads.

Boom Point - Quick-Reeve design features pass-through allowance for wire rope wedge and socket; makes quick work of parts of line configuration changes with practically no tools.

Wireline Sheave Head - Removable bracket constructed of high-strength low-alloy steel. Equipped with sheaves for wireline support and wireline crane operations. Sheave head supports 1 or 2 part reeving of Main Hoist Line; 1 part for Aux Hoist Line.

Boom Elevation - Double-acting hydraulic cylinder. Boom working range is 9° below horizontal to 80.4° above.

Load Hook - 5-ton (4,5 mton) capacity hook with heavy duty swivel, heavy duty safety latch and weight is provided for single line operation.

HOIST

Main Winch - Two-speed planetary reducer with wet multi-disc, spring-applied, hydraulically released internal brake and grooved drum; negative draft angle on flange to minimize line stacking while spooling. Maximum theoretical bottom-layer line pull 11,500 lbs (5,216 kg).

Auxiliary Winch - Single speed; wet multi-disc with spring-applied, hydraulically released internal brake. Maximum theoretical line speed 120 fpm (36,6 mpm). Maximum theoretical bottom-layer line pull 4000 lbs (1814 kg).

Wire Rope (Main) - 335' (102,11 m) of 9/16" (14,3 mm) diameter rotation resistant type.

Wire Rope (Aux) - 270' (82,3 m) of 3/8" (9,5 mm) diameter rotation resistant type.

SWING SYSTEM

Swing Drive - Externally mounted double reduction planetary driven hydraulic motor. Internal spring-applied, hydraulically released brake.

Rotation Bearing - Heavy duty ball bearing design, external gear.

Rotation - 372 ° non-continuous rotation with mechanical stops to protect internal plumbing. Maximum theoretical swing speed approximately 1.5 rpm

OUTRIGGERS

Front - Behind the cab out-down type intergraded into subframe. Fitted with double-acting hydraulic cylinders, each operate independently for precise leveling. Total outrigger overall spread is 19' 10" (6,1 m).

Rear - Pedestal mounted A-Link style outriggers. Fitted with into subframe. Fitted with double-acting hydraulic cylinders, each operate independently for precise leveling. Total outrigger overall spread is 22' 4" (6,8 m).

Single Rear Center - Single rear stabilizer with double-acting hydraulic cylinder. Mounted between the chassis rails behind the machine to maximize rear stability. Pad load is controlled by preset counterbalance to prevent overloading stabilizer. Stabilizer protected by auto-retract feature to prevent drive away damage.

MOUNTING

Clamp design, pedestal and subframe are secured to the truck chassis by means of threaded rods and clamp brackets. This system eliminates welding drilling or bolting to the truck frame.

Subframe - Torsionally resistant, rigid 4-plate fabricated design, with integrated forward out and down outriggers. Mounted under crane, full length of truck frame.

Rear Underride Protection - Supplied on all factory mounted cranes. Fabricated structure bolted to the rear of the truck frame. Complies with Bureau Motor Carrier Safety Standard 393.86.

Flatbed - WL series offered with two bed options; 18' (5,5 m) Heavy Duty steel bed and Knapheide brand 18' (5,5 m) Heavy Hauler steel bed with side rails.

Boom Rest - Heavy-duty fabrication, helps secure boom in place during traveling.

CONTROL SYSTEM

All crane functions are controlled by fully proportional hydraulic valves located in the control console. Control console has dual operator platforms with four single-lever crane controls arranged to ANSI B30.5 standards on each side. Each side is also equipped with controls and indicators including aux winch, outrigger and stabilizer controls, engine start/stop, foot throttle, signal horn, boom angle indicator, bubble levels, load chart, range diagram, beverage container and a system pressure gauge.

HYDRAULIC SYSTEMS

Hydraulic System - A 3-section gear pump direct-mounted to power take-off on truck transmission provides 32 gpm (121 lpm) to the hoist, 8 gpm (30

lpm) to the swing circuit and 21 gpm (79.5 lpm) to the other crane functions. Use of SAE O-ring and face seal O-ring hydraulic fittings throughout system.

Hydraulic Tank - Baffled, 100 gallon capacity reservoir equipped with two 25 micron filters on return side; shut-off ball valve and strainer on suction side.

Hydraulic Cylinders - All load holding cylinders equipped with integrated counterbalance or check valves to hold cylinders in position.

WARNING SYSTEMS

Load Moment Indicator - CANbus system maximizes expansion capabilities. Monitors boom hoist cylinder pressure, boom length and boom angle. Boom length sensor cable is internal to boom for protection. Audio-visual warnings indicates overload conditions; overload shut-off feature prevents continuing overload. Operator can access all relative crane configuration and load conditions via display at the operator station.

Radio Anti-Two-Block System - Audible warning and function shut-off prevent hook from contacting boom point. Wireless system eliminates downtime typically associated with damaged cables in wired systems. System monitors both main and aux hoist lines.

Back-up Alarm - Supplied on factory mounted cranes, electronic audible motion alarm activated when truck transmission is in reverse gear.

GENERAL

Electrical - State of the art weather resistant components throughout. Hermetically sealed power in relays. Enclosure includes power in relays and circuit status LEDs. Designed to withstand high pressure washing and varying climates. Automotive style connectorized harnesses for easy installation.

Design/Welding - Welding conforms to AWS D1.1. Design conforms to ANSI B30.5 (mobile cranes) and ANSI 92.2 (aerial devices).

Paint - Standard Manitex blue and gray.

Manuals - Operator and parts manuals depict correct machine operation, maintenance procedures and parts listings.

Warranty - 12-month warranty covers parts and labor resulting from defects in material and workmanship.

* In order to ensure continuous improvement, Manitex reserves the right to change design and specifications without notice.

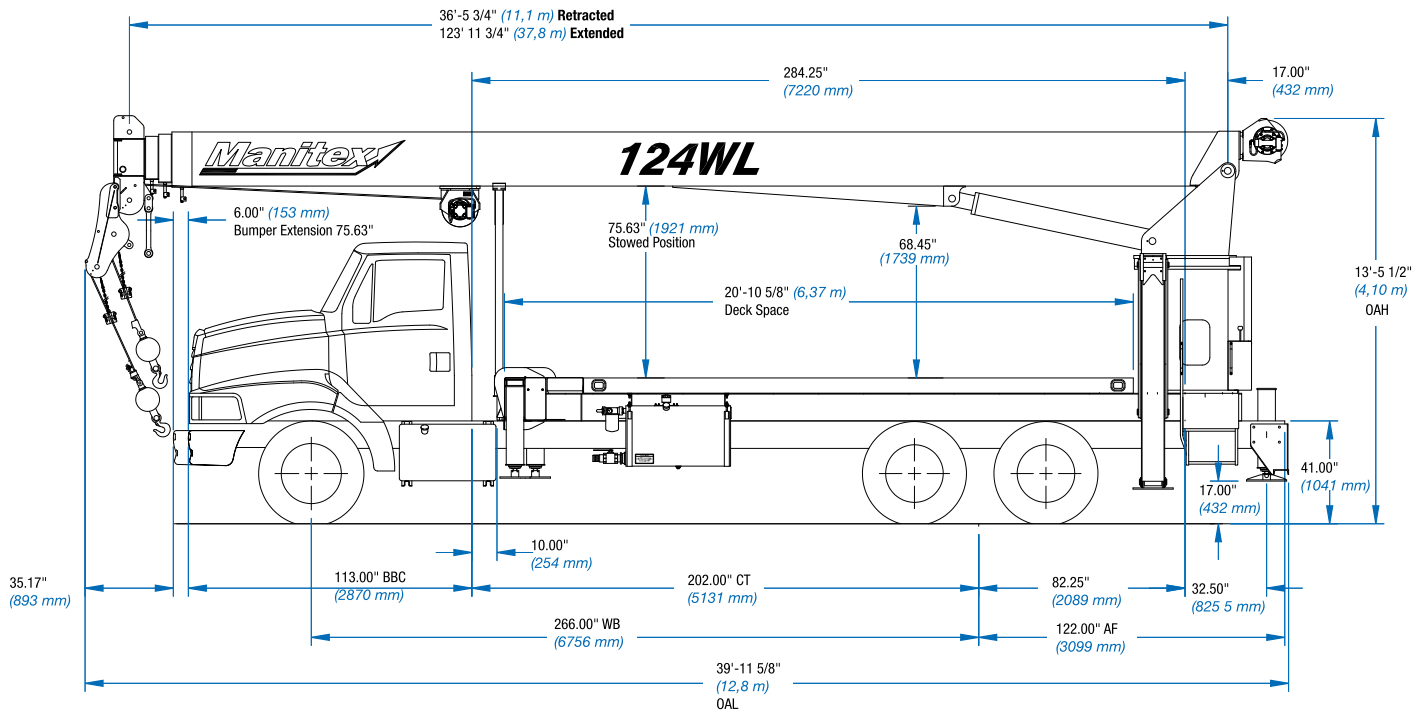

Typical Wireline configuration, does not reflect minimum truck requirement

CHASSIS DATA	102WL, 124WL LMI	102WL, 124WL HYCAS
Wheelbase (WB)	266" <i>6756 mm</i>	266" <i>6756 mm</i>
Cab to Tandem (CT)	202" <i>5131 mm</i>	202" <i>5131 mm</i>
Cab to end of Frame	324" <i>8230 mm</i>	324" <i>8230 mm</i>
Frame section modulus	30.0 in ³ 110,000 psi <i>758 422 kPa</i>	30.0 in ³ 110,000 psi <i>758 422 kPa</i>
Front Axle Gross Weight Rating	18,000 lb <i>8165 kg</i>	18,000 lb <i>8165 kg</i>
Rear Axle Gross Weight Rating	40,000 lb <i>18144 kg</i>	40,000 lb <i>18144 kg</i>
Minimum Truck Axle Weight - Front*	8450 lb <i>3833 kg</i>	8900 lb <i>4037 kg</i>
Minimum Truck Axle Weight - Rear*	8150 lb <i>3697 kg</i>	8100 lb <i>3674 kg</i>
Nominal Frame Width	34" <i>864 mm</i>	34" <i>864 mm</i>

* Minimum chassis weight is required to meet 85% stability requirements. Does not include weight of fuel or driver. Chassis data is general - not for engineering. Some dimensions change depending on truck selection.

MAXIMUM TIP HEIGHTS	102WL	124WL
Configuration	Boom 30'-6" <i>9,3 m</i>	Boom 36'-6" <i>11,1 m</i>
Extended Boom	158'-8" <i>48,4 m</i>	134'-8" <i>41 m</i>
Fixed or retracted Jib	139' <i>42,4 m</i>	N/A
Extended Jib	113' <i>34,4 m</i>	N/A

WEIGHTS	102WL	124WL
Total Crane - Standard	25586 lb <i>11606 kg</i>	27113 lb <i>12298 kg</i>
18' Flatbed	1720 lb <i>780 kg</i>	1720 lb <i>780 kg</i>
18' Heavy Duty Flatbed	2500 lb <i>1134 kg</i>	2500 lb <i>1134 kg</i>
26' (7,92 m) Fixed Length Jib	832 lb <i>377 kg</i>	N/A
26'-46' (7,92 m-14,02 m) Telescopic Jib	1226 lb <i>556 kg</i>	N/A

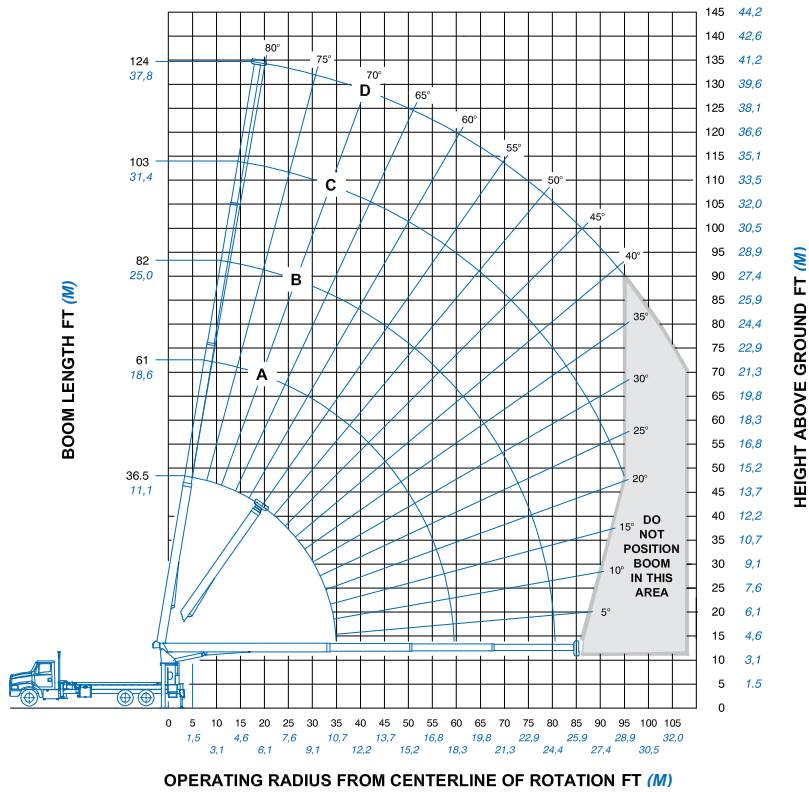

DEDUCTIONS	
Auxiliary Block	50 lb (22,68 kg)
Wireline Sheave Head	100 lb (45,36 kg)
Auxiliary Winch	200 lb (90,72 kg)
Overhaul Ball	See Overhaul Ball manufacturer's nameplate
Load Block	See Loadblock manufacturer's nameplate
Hose Reel	140 lb (63,50 kg)

Design meets ANSI B30.5 requirements.

Do not operate crane or accessories within 10' (3,05m) of live power lines.

NOTICE: This chart is for reference purposes only and must not be used for actual lifting purposes.

Consult factory for other boom options.

OUTRIGGERS AND STABILIZERS PROPERLY EXTENDED

MAIN BOOM LOAD RATINGS - Model 124WL

		Boom Length		A		B		C		D						
Operating Radius		36.5 Feet 11,1 Meters		61 Feet 18,6 Meters		82 Feet 25 Meters		103 Feet 31,4 Meters		124 Feet 37,8 Meters						
Feet	Meter	∠	lb	kg	∠	lb	kg	∠	lb	kg	∠	lb	kg			
6	1.83	81	50000	22680												
8	2.44	77	37820	17155												
10	3.05	74	31640	14352												
12	3.66	71	27260	12365	79	22200	10070									
15	4.57	66	22630	10265	77	20320	9217									
20	6.10	57	17650	8006	72	15530	7044	78	14600	6622						
25	7.62	46	14340	6505	67	12510	5674	74	11620	5271	79	10500	4763			
30	9.14	33	11680	5298	61	10410	4722	70	9570	4341	76	9020	4091	79	6500	2948
35	10.67	4	7590	3443	56	8840	4010	66	8060	3656	73	7540	3420	77	6100	2767
40	12.19				50	7600	3447	62	6900	3130	70	6400	2903	75	5800	2631
45	13.72				43	6280	2849	58	5970	2708	67	5500	2495	72	5150	2336
50	15.24				35	5190	2354	54	5200	2359	63	4760	2159	70	4430	2009
55	16.76				25	4170	1891	49	4380	1987	60	4150	1882	67	3830	1737
60	18.29							44	3540	1606	57	3620	1642	64	3320	1506
65	19.81							39	2860	1297	53	2970	1347	62	2880	1306
70	21.34							32	2290	1039	49	2400	1089	59	2460	1116
75	22.86							24	1800	816	45	1920	871	56	1980	898
80	24.38							9	1350	612	41	1500	680	53	1570	712
85	25.91										36	1150	522	50	1210	549
90	27.43										30	830	376	46	900	408
95	28.96										24	560	254	43	630	286

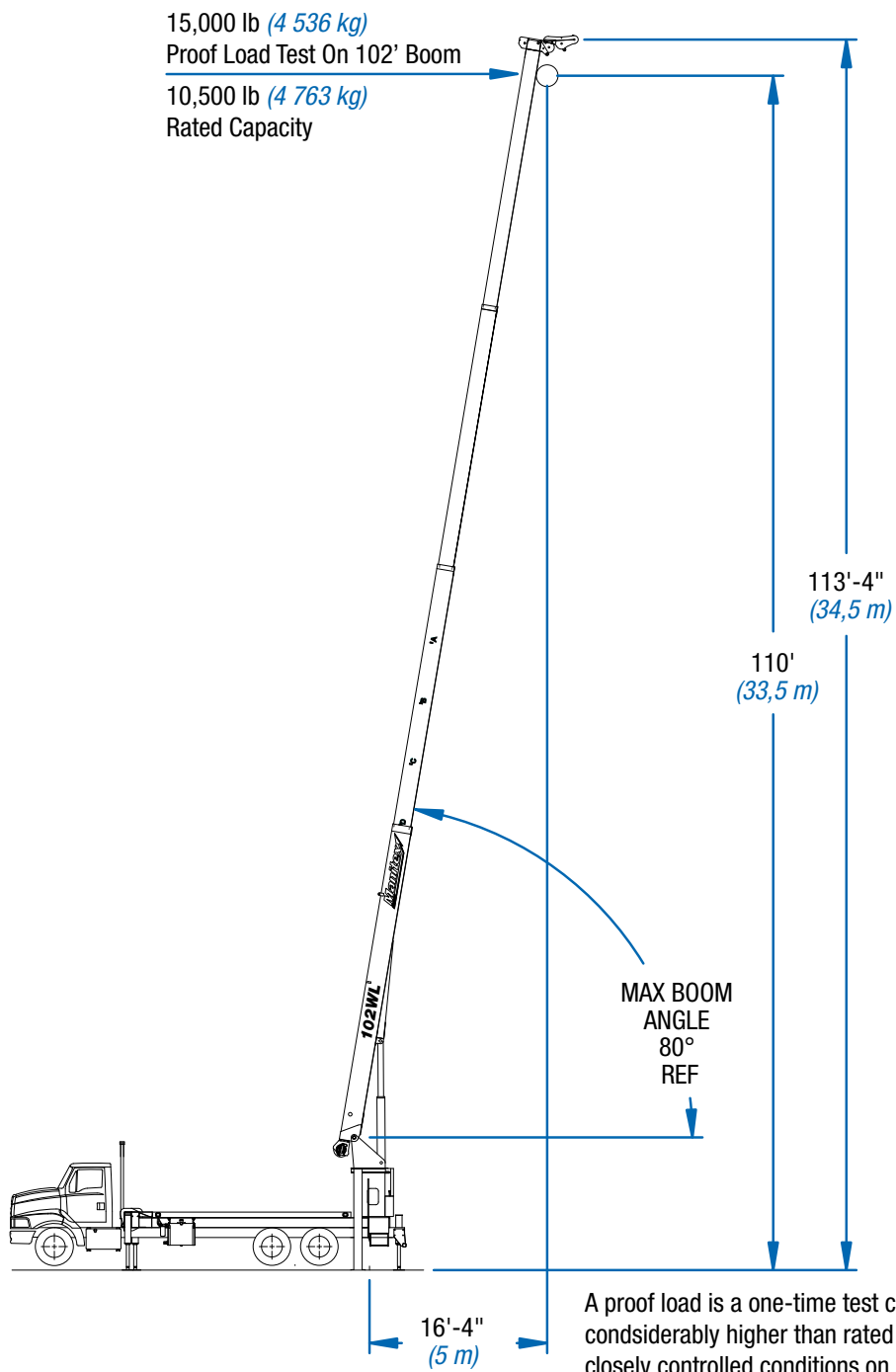

A proof load is a one-time test conducted at loads considerably higher than rated capacities under closely controlled conditions on a new or like new unit. The proof test assumes the load is fixed at the wellhead.

PROOF LOAD TEST DIAGRAM

Model 102WL

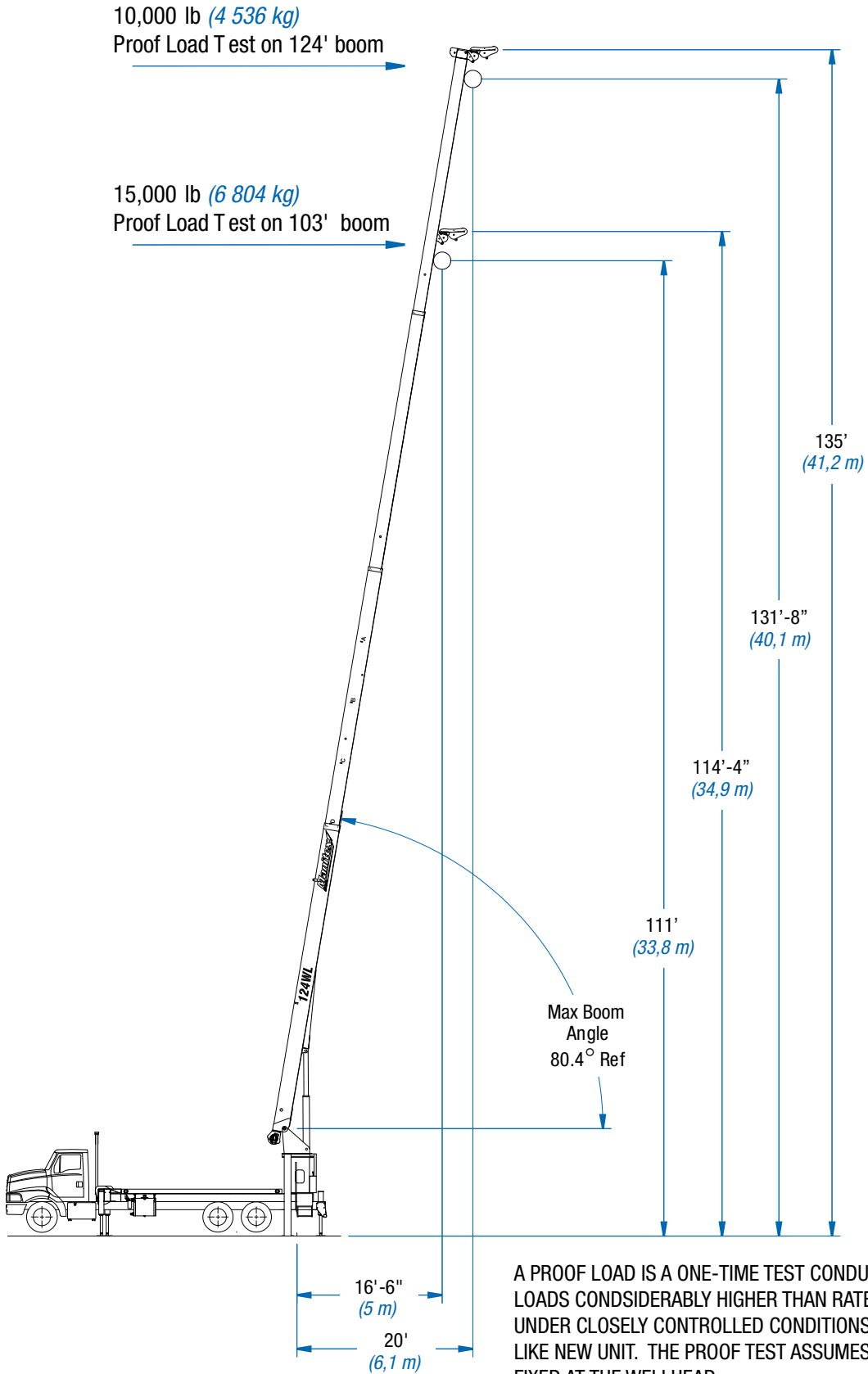

PROOF LOAD TEST DIAGRAM
Model 124WL

UPTime is the Manitex commitment to complete support of thousands of units working every day.

UPTime

- Includes 24-7-365 parts assistance.
- Utilizes the efficiency of COMNET online parts order system.
- Relies on Manitex's UPTrak support tracking system for performance analysis and resource allocation.
- Features REMan, Manitex's cost effective rebuild/exchange program.
- Provides expert service technicians for troubleshooting and site visits.
- Mandates training; at our facility and yours. It includes coordinated support from all component suppliers.
- Involves every Manitex team member in the support of every Manitex customer.

What does UPTime mean to Manitex customers?

UPTime means reliability.
UPTime means utilization.
UPTime means profitability.



Manitex
3000 South Austin Avenue
Georgetown, TX, USA 78626
Telephone 512-942-3000
Facsimile 512-863-3776
www.manitex.com