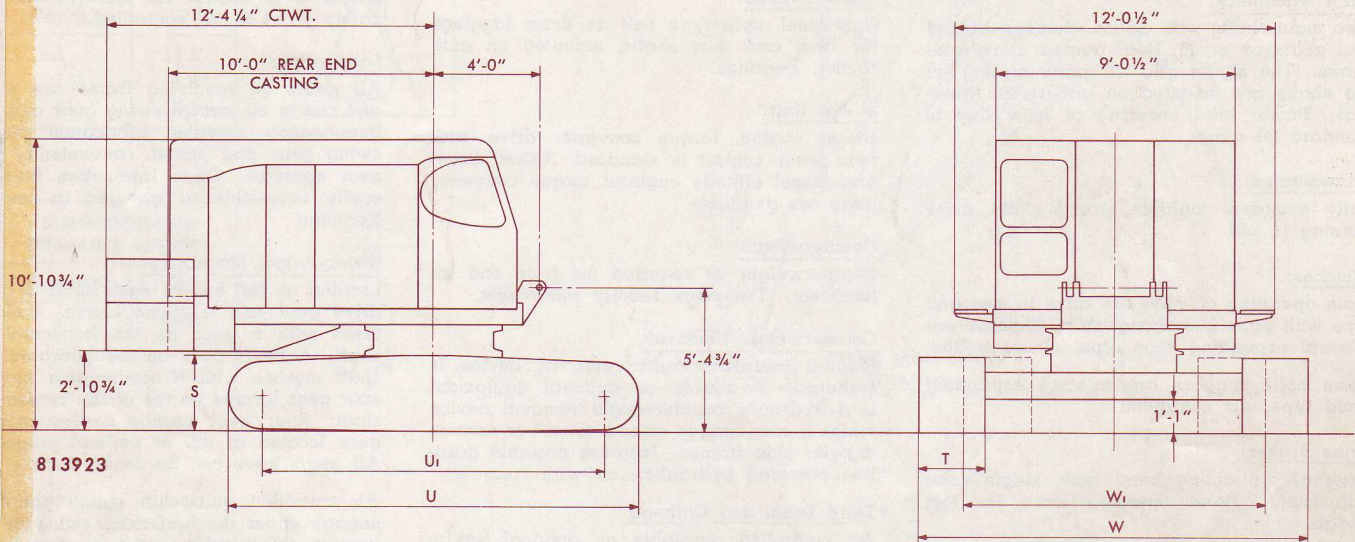

**B**

BUCYRUS-ERIE

**E****30-B**

SERIES FOUR

**SUPER CRAWLER MACHINE SPECIFICATIONS**

813923

**CRANE**

Aux. hoisting drum,  
grooved (rear shaft) .....18½" P. Dia.  
Aux. hoist rope .....¾" Dia.  
Hoisting drum,  
plain (front shaft) .....17½" P. Dia.  
Hoist rope .....⅞" Dia.  
Boom point sheaves (3) .....18½" P. Dia.

**CRAWLER MOUNTINGS**

Crawler Mountings	Height Tread Belts S	Width Treads T	Overall Length U	C. to C. Tumblers U <sub>1</sub>	Overall Width Extended W	Overall Width Retracted W <sub>1</sub>	Approx. Bearing Area Sq. Ft.
30" treads (Std.)	2' 10"	30"	16' 8"	14' 1"	14' 10"	11' 5½"	72.6
36" treads	2' 10"	36"	16' 8"	14' 1"	15' 4"	11' 11½"	87.6

**CLAMSHELL**

Holding drum, grooved .....18½" P. Dia.  
Holding rope, 1-part .....¾" Dia.  
Closing drum, plain .....17½" P. Dia.  
Closing rope, 1-part .....¾" Dia.  
Boom point sheaves (3) .....18" P. Dia.

**POWER SPECIFICATIONS**

Make Model Type	GM* 6-71 Diesel	CUM. H-743 Diesel	Cat* D-333CT Diesel
Type of Drive	Conv.	Conv.	Conv.
Cylinders	6	6	6
Bore x stroke, inches	4¼ x 5	5⅜ x 6	4¾ x 6
Displacement, cu. in.	426	743	638
Rated for excavator service:			
H.P. net @ full load speed	122	122	124
Full load speed output shaft	1470	1600	1470
Fuel tank capacity, gals.	70	70	70
Crankcase capacity, qts.	28	32	24
Cooling system capacity, gals.	11	21	12
Starting	12V-Elect.	12V-Elect.	12V-Elect.
Altitude range, feet	0-11,000	0-4000	0-12,500

\*Available as direct drive with 2-speed gear box.

**DRAGLINE**

Hoist drum, grooved .....18½" P. Dia.  
Hoist rope .....¾" Dia.  
Drag drum, grooved .....17½" P. Dia.  
Drag rope .....1" Dia.  
Boom point sheaves (3) .....18" P. Dia.

**LINE PULLS AND SPEEDS**

DRUM PITCH DIA.	1-Part Line		2-Part Line		3-Part Line	
	Pull In Lbs.	Speed F.P.M.	Pull In Lbs.	Speed F.P.M.	Pull In Lbs.	Speed F.P.M.
17½"	22,400	154	44,000	77	65,000	51
18½"	21,200	162	41,700	81	61,500	54
22"	17,800	193	35,000	96	51,600	64

Swing Speed 3.9 r.p.m. Propel Speed 1.0 m.p.h.<sup>f</sup>

Speeds and pulls based on engine operating at full load speed; direct drive.

Torque Converter Drive:

When torque converter is operating at full stall, line pulls are approximately 220% of those shown in table.

**WEIGHTS (LBS.)**

	ANGLE OR TUBULAR BOOM		
	Crane 40' Boom	Dragline 40' Boom	Clamshell 40' Boom
Net domestic, approx.	110,500	94,000	93,600
Working, approx.	110,950	96,350	96,500
Export shipping, approx.	111,100	96,650	96,800
Ships option tons	79	72	73

Hook block and buckets included in the working weight and export shipping weight, but not in domestic net weight.

# 30-B SUPER CRAWLER MACHINE

## UPPER WORKS

### Revolving Frame:

One-piece, heat treated steel casting with integral lugs for boom foot and hook roller mounting brackets. Cast steel machinery side frames are bolted to revolving frame. Shear plugs relieve bolts of shear loads and maintain alignment.

### Main Machinery:

Two main shafts with drums, clutches, brakes and gears on each. Heat treated alloy steel shafts. The shafts and all parts turning on the shafts are mounted on anti-friction bearings. Power load lowering of hoist line is standard for crane.

### Transmission:

Fully enclosed, multiple strand chain drive running in oil.

### Clutches:

Main operating clutches are alike in size and type with parts interchangeable. Clutches are internal expanding shoe type, air controlled.

Boom hoist clutches are internal expanding band type, air controlled.

### Drum Brakes:

External contracting band type, single point adjustment. Hand operated locks for foot pedals.

### Controls:

All functions air controlled, except for mechanically operated drum brakes, engine governor, output shaft governor, and swing lock. Main clutches and boom hoist clutches actuated by graduated type control valves, other air controlled motions actuated by poppet type air valves. Foot throttle is standard on crane. Single stick clamshell control standard on clamshell. Air control console is standard. 12 c.f.m. air compressor supplies compressed air for controls.

### Truck Frame:

Single unit, heat treated steel casting with integral double flanged roller path and swing gear. Lower roller path and swing gear teeth are hardened.

### Hook Rollers:

Eight adjustable conical hook rollers mounted on anti-friction bearings are standard. Two equalized pairs at front and rear, operating between a tapered double flanged roller path.

### Axles:

Heat treated cast alloy steel "I" section axles with ends machined to permit extending or retracting the crawler side frame assemblies. Axles are bolted to the truck frame. Pins are used to lock the side frames to the axle in the extended or retracted position.

### Crawler Side Frames:

Deep section welded units, composed of two channels spaced to support lower idler rollers, driving and take-up tumblers.

Side frames are mounted to the axles through tubular sections and secured in either extended or retracted with retaining pins.

Optional hydraulic device used for counterweight removal may also be used to remove, extend, or retract the crawler side frames.

### Swing Brake:

Friction type, spring set with air assist and air released, external contracting band type. Brake drum attached to top of vertical swing shaft. Independent positive house lock, mechanically operated, is available in addition to the swing brake.

### Cable Drums:

Cast steel, split type bolt on drum laggings for front and rear shafts, mounted on anti-friction bearings.

### Power Unit:

Diesel engine, torque converter drive with twin lever control is standard. Other diesel and diesel altitude engines; torque converter drive are available.

### Counterweight:

Counterweight as required for front end attachment. Two-piece readily removable.

### Counterweight Removal:

Manual counterweight removal device is standard. Available as optional equipment is a hydraulic counterweight removal device which is also used to extend, retract or remove crawler side frames. Includes portable gas-line powered hydraulic unit with controls.

### Third Drum and Cathead:

Air controlled available as optional equipment, mounted at boom foot. Cannot be used with dragline. With standard propel, air controlled clutch turns drum in one direction. Foot pedal operated mechanical brake with lock. When used with independent propel, power controlled lowering of drum is possible. Air controlled jaw clutches to select third drum, cathead or independent propel motions.

An alternate third drum is available as optional equipment, mounted on right side of rear shaft. Air controlled clutch, spring-set air released brake, single lever control. Single

line pull and speed based on engine operating at full load speed is 10,000# @ 162 FPM.

### Boom Hoist:

Independent boom hoist which provides positive power control of boom both up and down by individual air controlled friction clutches. Boom hoist brake is spring set, air released. Single lever control for clutches and brake. Safety pawl is air controlled.

### Lubrication:

All gears on revolving frame are enclosed and run in oil, except swing gear and pinion. Permanently mounted lubrication pump for swing gear and pinion, conveniently located near operator. Other lubrication fittings are easily accessible or grouped in centralized locations.

### Swing-Propel Machinery:

Located on left end of each shaft is a swing drive gear and a swing clutch. Both gears mesh with a gear on the horizontal swing shaft. A bevel gear on the horizontal swing shaft meshes with a combination bevel and spur gear located on top of the vertical swing shaft. Spur gear portion meshes with spur gear located at top of vertical propel shaft. All gears have cut, hardened teeth.

Air controlled, quick-shift, spline type clutches engage either the horizontal swing or propel gear to select either swing or propel motion. Clutches are interlocked so that only one may be engaged at a time.

### Independent Propel:

Single speed, air controlled, independent propel is available as an option. May be used with all front ends. When used with the third drum mounted forward of the front shaft, an air controlled jaw clutch is used to select either propel or third drum operation. High speed reverse standard. Low speed reverse optional.

## LOWER WORKS

### Crawler Treads:

Heat treated steel castings with hardened roller path. Single roller path for lateral flexibility. Two full floating pins, widely spaced, connect treads together to form crawler belts. 30" treads are standard, 36" treads are optional.

### Idler Rollers:

Lower rollers are bushed, heat treated steel castings secured to crawler side frames with U-bolts. Roller pins are hardened. Dust shields are provided, to protect the bearings.

### Driving and Take-Up Tumblers:

Driving tumblers are heat treated steel castings with driving lugs and are mounted on movable shafts for adjusting tension of propel drive chains. Large screws with spanner locks provided for adjustments.

The portion of the adjusting screws held in reserve for wear take-up are enclosed and packed in grease. Tumblers have bushing type bearings protected by dust shields.

### Lubrication:

Conveniently located lubrication fittings on crawler unit. All bearings on driving, take-up and lower roller shafts are lubricated through end of the shafts.

### Propel and Steering:

Swing clutches provide power for propelling after engaging horizontal propel gear through vertical and horizontal propel shafts. Horizontal propel shaft is made up of three parts, which when the jaw clutches are engaged, act as a single unit for driving the tread belts through a heavy chain drive.

Horizontal propel shaft extensions are coupled to the ends of the horizontal propel shaft by splined couplings and are supported by outboard bearings mounted on top of the crawler side frames.

Machine may be propelled with crawlers in retracted position. The driving sprockets are supported by the outboard bearings when crawler side frames are in the retracted position. Propel chains do not have to be disassembled to remove crawler side frames from the axles. Dirt guards are provided for the shaft extensions.

Steering jaw clutches are spring set-air released. An interlock prevents simultaneous disengagement of the steering jaw clutches. Steering brakes are spring set with air assist for extra holding and air released. Brakes are located outboard of steering clutches and also serve as digging brakes.

# 30-B SUPER DRAGLINE AND CLAMSHELL ANGLE OR TUBULAR BOOM

DIMENSIONS OF CLAMSHELL BUCKETS	
Capacity	R
1	11'5"
1¼	11'9"
1½	12'3"

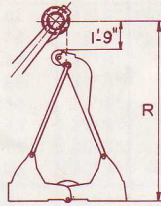

DIMENSIONS OF DRAGLINE BUCKETS	
Capacity	R
1	14'0"
1¼	15'0"
1½	16'0"

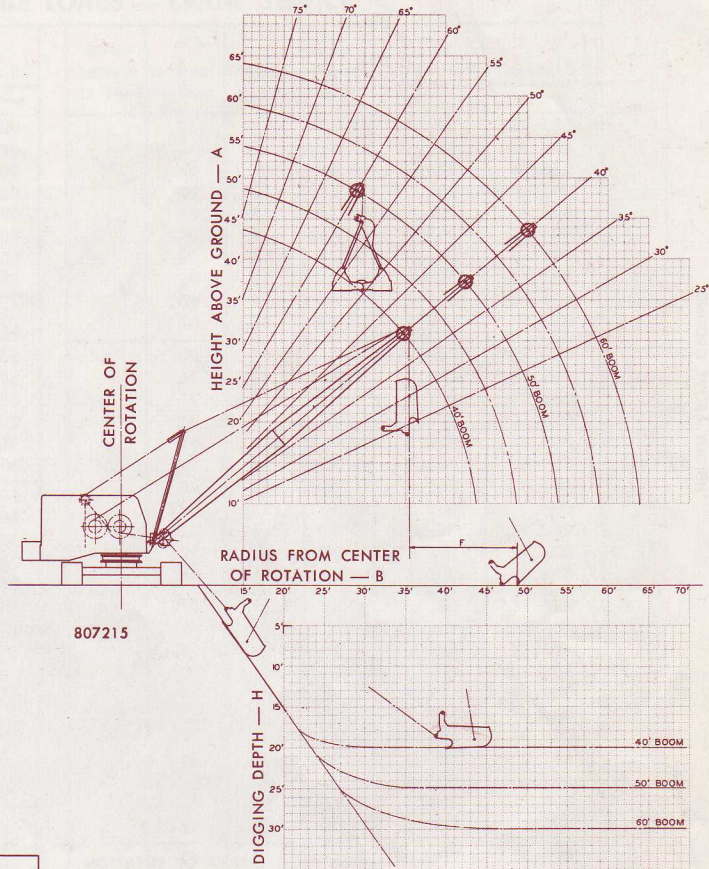
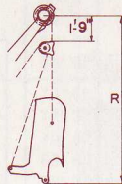

807215

MAXIMUM ALLOWABLE LOADS					
Boom Length Feet	Radius in Feet	Boom Angle in Degrees	Boom Point Pin Height	DRAGLINE	CLAMSHELL OR MAGNET
				Cwt. W-7	Cwt. W-7
40	25	58	39'6"	13,400	16,300
	30	49	35'9"	13,400	16,300
	35	39	30'9"	13,400	16,300
50	30	59	48'0"	13,400	16,300
	35	52	44'6"	13,400	16,300
	40	44	40'0"	13,300	13,300
60	45	35	36'9"	9,900	9,900
	35	59	56'9"	13,400	16,300
	40	53	53'6"	13,100	13,100
	45	47	49'3"	9,700	9,700
70	50	40	44'0"	7,250	7,250
	55	32	37'0"	5,450	5,450
	40	59	65'6"	12,700	12,700
	45	54	62'3"	9,300	9,300
70	50	49	58'3"	6,850	6,850
	55	43	53'0"	5,050	5,050

725660K1

Dragline loads do not exceed 75% of tipping loads with the boom in the least stable position and machine on firm level ground. Recommended maximum allowable loads for general dragline service are those shown in the chart, but not to exceed 13,400 lbs. for weight of bucket and contents.

Clamshell or magnet loads do not exceed 66-2/3% of tipping loads with the boom in the least stable position and machine on firm level ground. Recommended maximum allowable loads for general clamshell or magnet service are those shown in the chart, but not to exceed 16,300 lbs. for weight of bucket or magnet and material handled.

Boom angles less than 30° or greater than 60° are not recommended for dragline or clamshell service.

### DRAGLINE AND CLAMSHELL WORKING RANGES

- A - Dumping height; height of boom point sheave minus dimension "R" shown in table above.
- B - Dumping radius; approximately same as operating radius.
- F - Throw of dragline bucket; depends on ability of operator, usually 1/3 to 1/2 of boom length.
- H - Digging depth with dragline bucket; depends on character of material, size and type of dragline bucket and whether end cut or side cut. Because of these variables, digging depths shown cannot be guaranteed. Digging depths with clamshell bucket are approximately 8' greater than for dragline operation when using standard ropes. Tagline equipment has rope of sufficient length to reach depths greater than standard hoist rope allows.

**Notes:**

1. Recommended maximum length of boom for general dragline, clamshell, magnet or similar service is 70 feet.
2. Due to possibility of clamshell bucket or magnet striking the boom, care should be exercised when operating with boom angles greater than 60°.
3. Loads must be reduced when operating on soft or uneven ground, for bucket suction or other unfavorable conditions.

# 30-B SUPER CRANE—TUBULAR BOOM

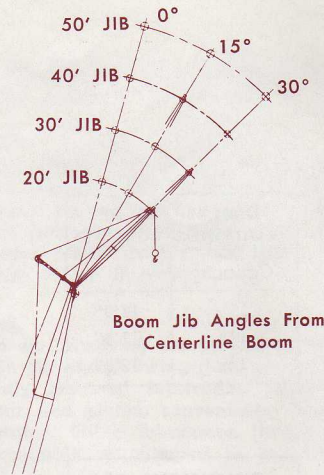
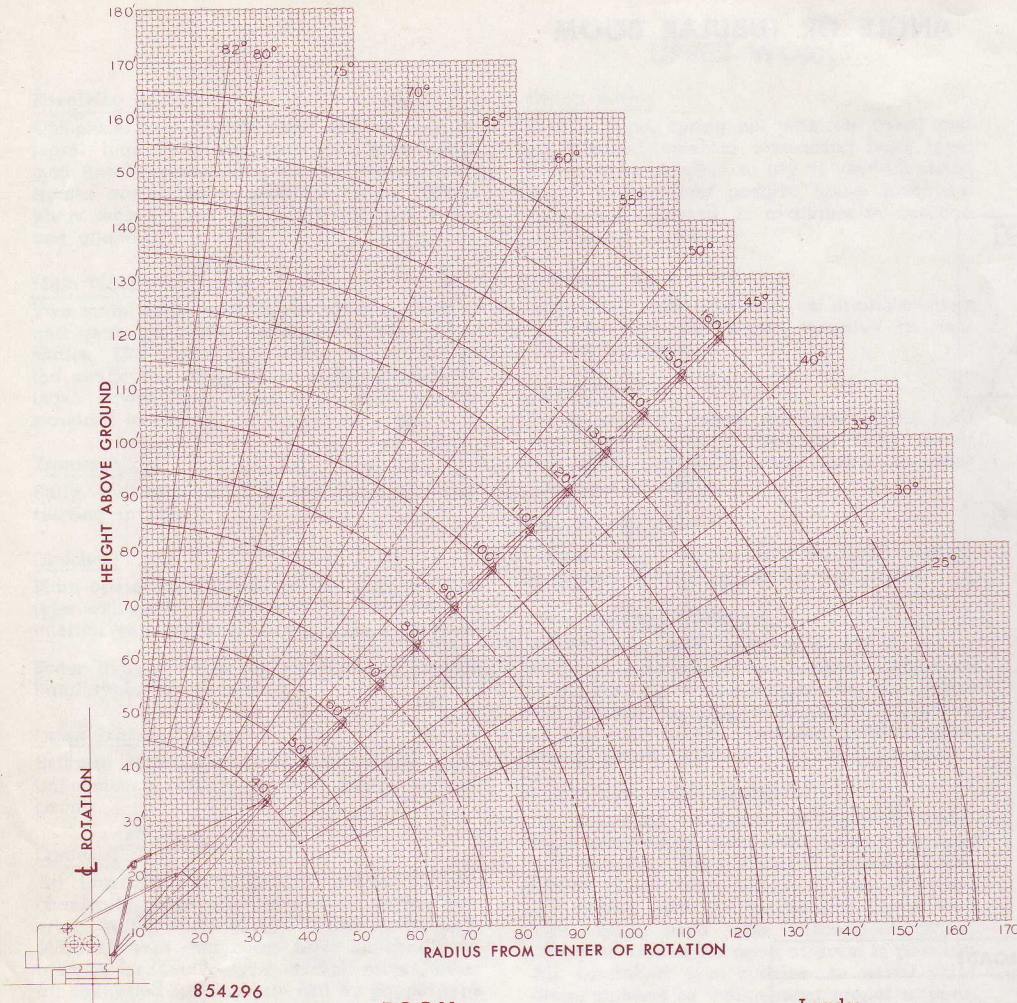

Boom Jib Angles From Centerline Boom

HOOK BLOCKS			
Capacity	No. Parts	Y	Weight
5 Ton	1	4'0"	375#
20 Ton	2	5'6"	390#
35 Ton	4	16'0"	580#
60 Ton	6	16'0"	1050#

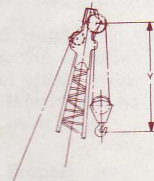

## BOOM

### Construction:

Standard boom is 40' long fabricated from alloy steel tubes, all-welded construction. Sections connected with single pin type joints. Insert sections 10', 20' and 30' long are available. Three boom point sheaves mounted on anti-friction bearings are standard. Four boom point sheaves optional.

### Suspension:

Twelve-part tackle with mast and pendant suspension is standard. Intermediate suspension required for booms 140' and longer.

### Maximum Length:

Maximum length of boom for crane service is 160'. Maximum boom and jib combination is 160' + 50'. Maximum boom or boom and jib combination lengths that can be lifted off the ground unassisted are:

	Over Side	Over End
Boom	160'	160'
Boom and Jib	140' + 50'	160' + 50'

The maximum boom length that can be propelled with the boom below cab height is 120'. The maximum boom and jib that can be carried over the end of the crawlers when propelling is 120' + 40'. Clearance height of jib mast with boom horizontal and jib in line with boom is 14'6".

Maximum length of boom to which a jib may be attached is 160'.

### Maximum Angle:

Maximum boom angle is 82°. Telescoping tubular type boom stops are standard on crane.

## JIB

### Construction:

Jibs are fabricated from alloy steel tubes, all welded construction. Jib lengths of 20', 30', 40' or 50' long are available. Point sheave mounted on anti-friction bearing is standard.

### Loads:

Use jibs for crane service only. Allowable load on main boom sheave, when jib is attached, must be reduced as follows:

20' Jib	900 Lbs.
30' Jib	1,000 Lbs.
40' Jib	1,200 Lbs.
50' Jib	1,500 Lbs.

## HOIST TACKLE

### Parts:

Suggested parts of hoist tackle are as follows:

Loads Over	20,000#	40,000#	60,000#	80,000#	100,000#
Parts of Line	2	3	4	5	6

Maximum allowable loads apply only to machines that are level and standing on hard level uniform supporting surfaces. Loads must be freely suspended. The radii specified are loaded radii. Ratings include blocks, hooks, slings or other equipment used in handling loads. Proper care must be exercised by the operator at all times to avoid shock or side loadings on the boom. Ratings apply only to machines having booms in first class condition built and recommended by Bucyrus-Erie Company.

\* Indicates that maximum allowable load is limited by factors other than tipping.

1† Loads in column one do not exceed 75% of tipping loads with the boom in the least stable position in accordance with U. S. Department of Commerce Commercial Standard CS90-58.

2‡ Loads in column two do not exceed 85% of tipping loads with the boom in the least stable position.

# 30-B SUPER CRANE—TUBULAR BOOM

## 60-TON CRAWLER CRANE (P.C.&S.A. CLASS 12-230)

MAXIMUM ALLOWABLE LOADS — CRANE SERVICE															
Boom Length In Feet	Radius In Feet	Boom Angle In Deg	Boom Point Pin Ht	Column 1†		Column 2‡		Boom Length In Feet	Radius In Feet	Boom Angle In Deg	Boom Point Pin Ht	Column 1†		Column 2‡	
				Cwt. W-8	Cwt. W-8	Cwt. W-8	Cwt. W-8					Cwt. W-8	Cwt. W-8		
40	10	81	45' 0"	*120,000	*120,000	120	25	80	123' 6"	41,500	47,100				
	12	78	44' 6"	*120,000	*120,000		30	77	122' 6"	32,100	36,400				
	15	74	43' 9"	94,100	106,600		40	73	119' 9"	21,600	24,500				
	20	66	42' 0"	59,300	67,200		50	67	116' 3"	15,900	18,100				
	25	58	39' 6"	43,100	48,800		60	62	111' 6"	12,400	14,000				
	30	49	35' 9"	33,700	38,200		70	57	105' 6"	9,900	11,200				
	35	39	30' 9"	27,600	31,200		80	51	98' 3"	8,100	9,200				
50	40	26	22' 9"	23,300	26,400	90	44	89' 0"	6,700	7,600					
	12	81	54' 9"	*110,000	*110,000	100	37	77' 6"	5,700	6,400					
	15	77	54' 3"	93,900	106,400	110	28	61' 9"	4,800	5,500					
	20	71	52' 9"	59,100	67,000	140	30	79	143' 0"	31,600	*32,000				
	25	65	50' 9"	42,900	48,600		40	75	140' 9"	21,200	24,000				
	30	59	48' 0"	33,400	37,900		50	71	137' 9"	15,500	17,500				
	35	52	44' 9"	27,300	30,900		60	66	133' 9"	11,900	13,500				
40	44	40' 0"	23,000	26,100	70		62	129' 9"	9,400	10,700					
50	23	25' 0"	17,300	19,600	80		57	123' 0"	7,600	8,700					
70	20	77	73' 6"	58,700	66,600		90	52	115' 9"	6,200	7,100				
	25	73	72' 3"	42,500	48,200	100	47	107' 3"	5,200	5,900					
	30	68	70' 6"	33,000	37,500	110	41	96' 9"	4,300	4,900					
	40	59	65' 6"	22,600	25,600	120	34	83' 9"	3,600	4,100					
	50	49	58' 3"	16,900	19,200	130	26	66' 6"	3,000	3,400					
	60	37	47' 6"	13,400	15,200	150	30	80	153' 3"	*29,000	*29,000				
	70	19	28' 9"	10,900	12,400		40	76	151' 0"	21,000	23,800				
80	20	78	83' 9"	58,500	66,300		50	72	148' 3"	15,300	17,300				
	25	75	82' 6"	42,300	47,900		60	68	144' 6"	11,700	13,300				
	30	71	81' 9"	32,800	37,200		70	64	140' 0"	9,200	10,500				
	40	63	76' 9"	22,400	25,400		80	60	134' 9"	7,400	8,400				
	50	55	70' 9"	16,700	18,900		90	55	128' 3"	6,100	6,900				
	60	46	62' 6"	13,100	14,900	100	50	120' 9"	5,000	5,700					
	70	34	50' 6"	10,700	12,100	110	45	111' 6"	4,100	4,700					
100	25	78	103' 3"	41,900	47,500	120	39	100' 6"	3,400	3,900					
	30	75	102' 0"	32,500	36,800	130	33	86' 9"	2,800	3,200					
	40	69	98' 9"	22,000	25,000	160	40	77	161' 3"	20,800	*21,900				
	50	63	94' 3"	16,300	18,500		50	73	158' 9"	15,100	17,100				
	60	56	88' 3"	12,700	14,500		60	70	155' 3"	11,500	13,000				
	70	49	80' 6"	10,300	11,700		70	66	151' 3"	9,000	10,200				
	80	41	70' 6"	8,500	9,600		80	62	146' 3"	7,200	8,200				
90	31	56' 6"	7,100	8,100	90		57	140' 3"	5,900	6,700					
110	25	79	113' 3"	41,700	47,300		100	53	133' 6"	4,800	5,400				
	30	76	112' 3"	32,300	36,600	110	49	125' 3"	3,900	4,500					
	40	71	109' 3"	21,800	24,700	120	44	115' 6"	3,200	3,000					
	50	65	105' 3"	16,100	18,300										
	60	59	100' 0"	12,500	14,200										
	70	53	93' 6"	10,100	11,400										
	80	46	85' 0"	8,300	9,400										

725677K1

MAXIMUM ALLOWABLE LOADS — JIB (LBS.)													
Boom Length In Feet	Boom Angle In Degrees	Jib Length											
		20' Jib			30' Jib			40' Jib			50' Jib		
		Offset Angle †			Offset Angle †			Offset Angle †			Offset Angle †		
		0°	15°	30°	0°	15°	30°	0°	15°	30°	0°	15°	30°
40 to 100	78	20,000	20,000	12,000	16,000	12,000	7,000	16,000	10,000	5,000	14,000	8,000	3,000
	75	20,000	18,000	12,000	16,000	12,000	6,000	16,000	9,000	5,000	13,000	6,000	3,000
	69	17,000	15,000	10,000	12,000	10,000	6,000	12,000	7,000	4,000	10,000	5,000	3,000
	63	12,800	11,700	10,000	9,000	8,000	6,000	8,000	5,000	4,000	6,000	4,000	3,000
	56	9,600	9,200	8,800	8,000	7,000	5,500	7,500	4,500	3,500	5,500	3,500	—
	49	7,600	7,400	7,300	7,000	6,000	5,000	6,200	4,000	3,000	5,000	3,000	—
	41	6,200	6,000	6,000	5,600	5,000	5,000	5,000	—	—	4,000	—	—
110 to 160	31	5,000	5,000	5,000	—	—	—	—	—	—	—	—	—
	77	14,000	14,000	12,000	14,000	12,000	6,000	10,000	8,000	4,500	5,000	4,000	3,000
	73	12,000	11,000	10,000	10,000	9,800	6,000	9,000	7,000	4,500	5,000	4,000	3,000
	70	9,500	8,500	8,000	8,000	8,000	6,000	8,000	6,000	4,500	5,000	4,000	3,000
	66	7,200	6,700	6,500	6,700	6,000	5,700	6,000	5,000	4,500	5,000	3,000	—
	62	5,600	5,400	5,200	5,000	4,700	4,500	4,500	4,300	4,000	4,000	3,000	—
	57	4,200	4,000	3,800	3,800	3,800	3,400	3,000	3,000	3,000	3,000	—	—
53	3,400	3,200	3,100	3,000	3,000	—	—	—	—	—	—	—	

The above jib loads are based on factors other than stability.  
 †Maximum offset (Angular) from centerline of boom to centerline of jib.  
 Machine equipped with super crawlers 30" or 36" links and counterweight W-8.

# 30-B SUPER CRANE — ANGLE BOOM

## 60 TON CRAWLER CRANE (P. C. & S. A. CLASS 12-227)

## BOOM

MAXIMUM ALLOWABLE LOADS — CRANE SERVICE					
Boom Length In Feet	Radius In Feet	Boom Angle In Deg	Boom Point Pin Ht	Column 1 †	Column 2 ‡
				Ctwt. W-8	Ctwt. W-8
40	10	82	45' 0"	*120,000	*120,000
	12	79	44' 9"	*120,000	*120,000
	15	74	43' 9"	93,800	*106,300
	20	67	42' 0"	59,100	67,000
	25	58	39' 6"	42,800	48,600
	30	50	35' 9"	33,400	37,900
	35	39	30' 9"	27,300	31,000
40	26	22' 9"	23,000	26,000	
50	12	81	54' 9"	*110,000	*110,000
	15	77	54' 3"	93,600	*100,000
	20	71	52' 9"	58,800	66,600
	25	65	50' 9"	42,500	48,200
	30	59	48' 0"	33,100	37,500
	35	52	44' 9"	27,000	30,600
	40	44	40' 0"	22,700	25,700
50	23	25' 0"	17,000	19,300	
60	15	79	64' 6"	93,400	* 94,000
	20	74	63' 3"	58,600	66,400
	25	70	61' 9"	42,400	48,000
	30	64	59' 6"	33,000	37,300
	40	53	53' 6"	22,500	25,500
	50	40	44' 0"	16,800	19,000
	60	21	27' 0"	13,200	15,000
70	20	77	73' 6"	58,400	66,100
	25	73	72' 3"	42,100	47,700
	30	68	70' 3"	32,700	37,000
	40	59	65' 6"	22,200	25,200
	50	49	58' 3"	16,500	18,700
	60	37	47' 6"	12,900	14,700
	70	19	28' 9"	10,500	11,900
80	20	78	83' 9"	58,100	65,000
	25	75	82' 6"	41,800	47,400
	30	71	81' 0"	32,400	36,700
	40	63	76' 9"	21,900	24,900
	50	55	70' 9"	16,300	18,400
	60	46	62' 6"	12,700	14,400
	70	34	50' 6"	10,200	11,600
100	30	75	102' 0"	32,000	36,200
	40	69	98' 9"	21,500	24,300
	50	63	94' 3"	15,800	17,900
	60	56	88' 3"	12,200	13,800
	70	49	80' 6"	9,700	11,000
	80	41	70' 6"	7,900	9,000
	90	31	56' 6"	6,600	7,500
120	30	77	122' 6"	31,500	* 32,500
	40	73	120' 0"	21,000	23,800
	50	67	116' 3"	15,300	17,300
	60	62	111' 6"	11,700	13,300
	70	57	105' 6"	9,300	10,500
	80	51	98' 3"	7,500	8,500
	90	44	89' 0"	6,100	6,900
	100	37	77' 6"	5,000	5,700
	110	28	61' 9"	4,200	4,700
	130	30	78	132' 9"	* 29,000
40		74	130' 3"	20,700	23,200
50		69	127' 0"	15,000	17,000
60		64	122' 9"	11,400	12,900
70		59	117' 6"	9,000	10,200
80		54	110' 9"	7,200	8,100
90		49	103' 0"	5,800	6,600
100		42	93' 0"	4,700	5,400
110		35	80' 9"	3,900	4,400
120		27	64' 0"	3,100	3,600

823324K1

The above ratings apply only to machines that are level and standing on hard level uniform supporting surfaces. Loads must be freely suspended. The radii specified are loaded radii. Ratings include blocks, hooks, slings or other equipment used in handling loads. Proper care must be exercised by the operator at all times to avoid shock or side loadings on the boom. Ratings apply only to machines having booms in first class condition built and recommended by Bucyrus-Erie Company.

\* Indicates that maximum allowable load is limited by factors other than tipping.

1† Loads in column one do not exceed 75% of tipping loads with the boom in the least stable position in accordance with U.S. Department of Commerce Commercial Standard CS90-58.

2‡ Loads in column two do not exceed 85% of tipping loads with the boom in the least stable position.

### Construction:

Standard boom is 40' long fabricated from alloy steel angles, all-welded construction. Sections connected with single bolt, butt type, machined joints. Insert sections 10', 20' and 30' long are available. Three boom point sheaves mounted on anti-friction bearings are standard. Four boom point sheaves optional.

### Suspension:

Twelve-part tackle with mast and pendant suspension is standard.

### Maximum Length:

Maximum length of boom for crane service is 130'. Maximum boom and jib combination is 130' + 50'. Maximum boom or boom and jib combination lengths that can be lifted off the ground unassisted are:

Boom	Butt Type Joint	Pin Type Joint
Over Side	130'	130'
Over End	130'	130'
Boom and Jib		
Over Side	120' + 50'	120' + 50'
Over End	130' + 50'	130' + 50'

The maximum boom length that can be carried with the boom and mast below cab height, over the end, when traveling is 120'. The maximum boom and jib that can be carried over the end of the crawlers when propelling is 120' + 40' clearance height of jib mast with boom horizontal and jib in line with boom is 13'4".

Maximum length of boom to which a jib may be attached is 130'.

### Maximum Angle:

Maximum boom angle is 82°. Telescoping tubular type boom stops are standard on crane.

## JIB

### Construction:

Jibs are fabricated from alloy steel angles, all-welded construction. Jib lengths of 10', 20', 30', 40' or 50' long are available. Point sheaves mounted on anti-friction bearing is standard.

### Loads:

Use jibs for crane service only. Allowable load on main boom sheave, when jib is attached, must be reduced as follows:

10' Jib .....	1,300 Lbs.
20' Jib .....	1,600 Lbs.
30' Jib .....	1,800 Lbs.
40' Jib .....	2,100 Lbs.
50' Jib .....	2,300 Lbs.

## HOIST TACKLE

### Parts:

Suggested parts of hoist tackle are as follows:

Loads Over	20,000 #	40,000 #	60,000 #	80,000 #	100,000 #
Parts of Line	2	3	4	5	6

# 30-B SUPER CRANE — ANGLE BOOM

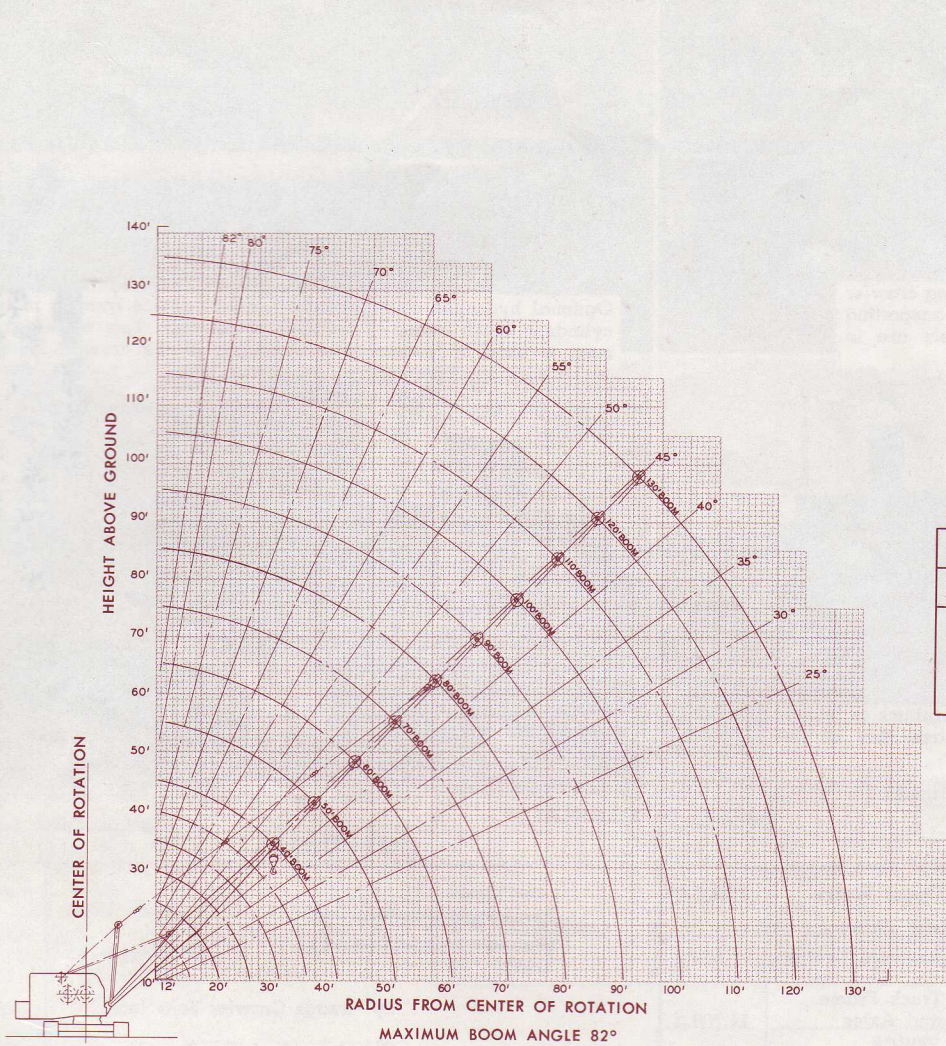

807209

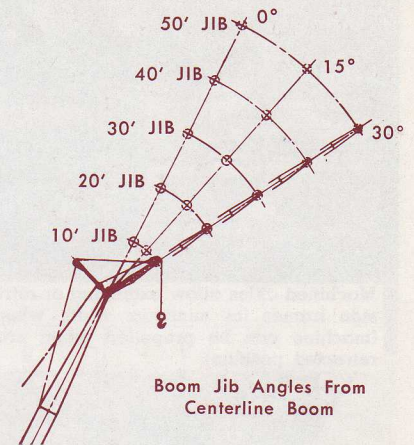

Boom Jib Angles From Centerline Boom

HOOK BLOCKS			
Capacity	No. Parts	Y	Weight
5 Ton	1	4'0"	220#
20 Ton	2	5'6"	390#
35 Ton	4	16'0"	580#
60 Ton	6	16'0"	1050#

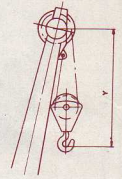

MAXIMUM ALLOWABLE LOADS — JIB (LBS.)																
Boom Length In Feet	Boom Angle In Degrees	Jib Length														
		10' Jib			20' Jib			30' Jib			40' Jib			50' Jib		
		Offset Angle †			Offset Angle †			Offset Angle †			Offset Angle †			Offset Angle †		
		0°	20°	40°	0°	15°	30°	0°	15°	30°	0°	15°	30°	0°	15°	30°
40' to 90'	77	20,000	20,000	14,000	20,000	20,000	12,000	16,000	12,000	7,000	15,800	10,000	5,000	11,200	8,000	3,000
	73	20,000	20,000	12,000	20,000	18,000	12,000	16,000	10,000	6,000	14,500	8,000	5,000	10,500	6,000	3,000
	66	18,000	18,000	10,000	16,000	14,000	10,000	10,000	9,000	6,000	10,000	6,000	4,000	8,000	4,000	3,000
	59	15,000	14,000	9,000	12,000	12,000	9,000	9,000	8,000	6,000	8,000	5,000	4,000	6,000	4,000	3,000
	52	11,500	11,000	8,000	10,000	9,500	8,000	8,000	6,000	5,000	7,000	4,000	3,500	5,000	3,500	—
	43	9,300	9,000	7,000	8,000	7,500	7,000	6,000	5,500	5,000	5,500	4,000	3,000	4,000	3,000	—
32	7,300	7,000	—	6,000	6,000	—	5,500	4,000	—	5,000	4,000	—	3,000	—	—	
100' to 130'	78	14,000	14,000	12,000	14,000	14,000	12,000	14,000	12,000	6,000	12,000	10,000	5,000	10,000	3,000	3,000
	74	13,000	13,000	12,000	13,000	13,000	12,000	12,000	12,000	6,000	12,000	9,000	5,000	10,000	3,000	3,000
	69	11,000	11,000	10,000	11,000	11,000	10,000	8,000	8,000	6,000	9,000	7,000	4,000	9,000	3,000	3,000
	64	8,000	8,000	8,000	8,000	8,000	8,000	7,000	7,000	6,000	7,000	6,000	4,000	7,000	3,000	3,000
	59	6,000	6,000	6,000	6,000	6,000	6,000	6,000	6,000	6,000	6,000	5,000	4,000	6,500	—	—
	54	5,000	5,000	5,000	5,000	5,000	5,000	5,000	5,000	4,700	4,700	4,200	4,000	4,200	—	—
49	4,000	4,000	4,000	4,000	4,000	4,000	4,000	4,000	4,000	3,700	3,700	3,200	3,000	—	—	
42	3,000	3,000	3,000	3,000	3,000	3,000	3,000	3,000	3,000	—	—	—	—	—	—	

731905K1

The above loads are based on factors other than stability.  
 †Maximum offset (Angular) from centerline of boom to centerline of jib.  
 Machine equipped with super crawlers 30" or 36" links and counterweight W-8.

# 30-B SUPER CRAWLER MACHINE

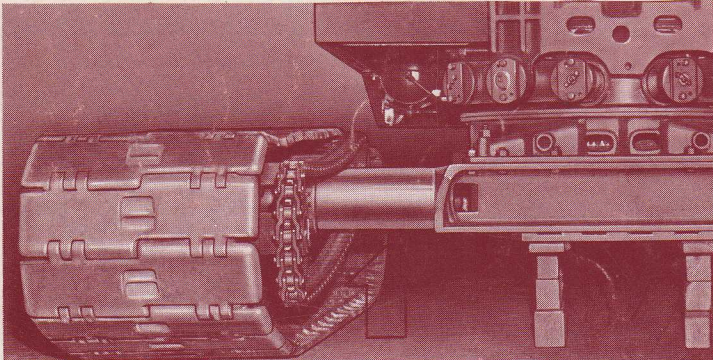

Machined axles allow extending or retracting crawler side frames for minimum width when transporting (machine can be propelled when crawlers are in retracted position).

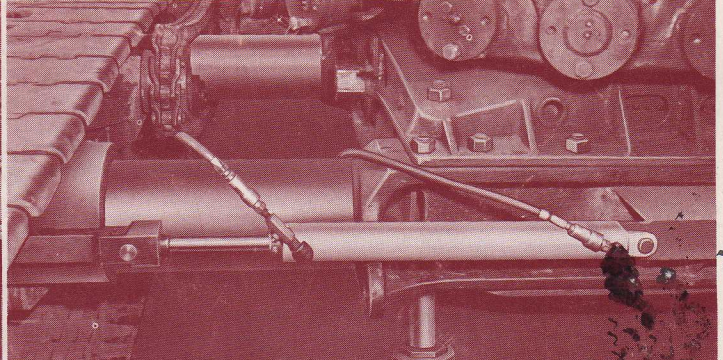

Optional hydraulic counterweight removal device consists of two cylinders which attach to the rear of the cab. This same equipment is used for extension or retraction of the crawler frames.

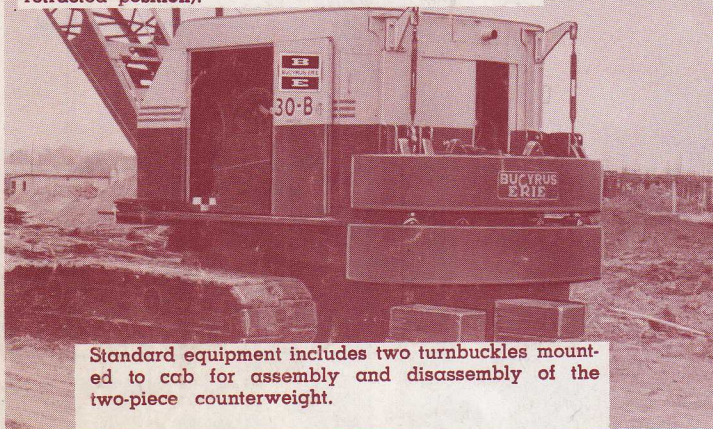

Standard equipment includes two turnbuckles mounted to cab for assembly and disassembly of the two-piece counterweight.

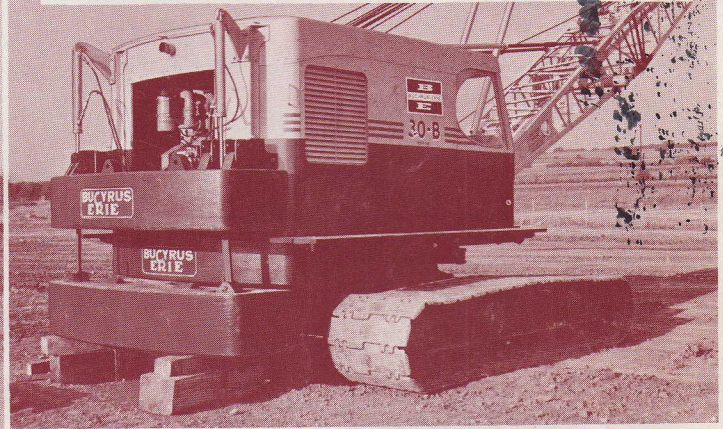

## WEIGHTS OF ASSEMBLIES

MACHINERY		CRAWLERS	
	Upper Works	33,900 #	
	Standard Cwt. Removal Device	500 #	
	Truck Frame and Axles	11,700 #	
	(For hydraulic Cwt. removal device add 215 lbs.)		
<b>Total</b>	<b>46,100 #</b>	30" treads Crawler Belts (each) 5,350 # Crawler side frame (each) 6,600 # (For 36" treads add 500 lbs. per belt.) Two Crawler assemblies <b>Total</b> 23,900 #	
COUNTERWEIGHT		FRONT END	
	Upper Cwt.	17,800 #	
	Lower Cwt.	17,300 #	
	<b>Total</b>	<b>35,100 #</b>	
	Standard Alloy Angle Boom 21'6" Upper Section 2,020 # 18'6" Lower Section 1,800 # 5' Pendant (2) 190 # 21' Pendant (2) 270 # Mast 500 # Bridle 380 # Boom Stop 240 # <b>Total</b> 5,400 #		



## BUCYRUS-ERIE COMPANY

Construction Machinery Division: Evansville, Indiana

General Offices: South Milwaukee, Wisconsin, U. S. A.

It is the policy of Bucyrus-Erie Company to improve its products continually. The right is reserved to make changes in specifications or design which in the opinion of this company are in accord with this policy, or which are necessitated by the unavailability of materials. The description herein is for the purpose of identifying the type of machine, and does not limit or extend the express warranty provisions in any contract of sale.

