

# Series 900H

**preliminary  
guide**

## features

- **New design**
- **105 ft (32.0 m) Four-section boom**
- **27 USt (24.5 t) rating**
- **Multi-position Easy Reach control panel**
- **Graphical LMI**

## contents

**Features**

**2**

**Mounting Configurations**

**3**

**Specifications**

**4**

**Capacities**

**5**

**Accessories**

**9**

**Dimensions  
Specifications**

**10**



\*Product may be shown with optional equipment.

# features

## Why Buy a National Crane Series 900H

2



\*Product may be shown with optional equipment.

- **27 USt (24.5 t) Rating** – The new 900H provides a 27 USt (24.5 t) capacity.
- **105 ft (32.0 m) Four-section Boom** – The longest in its size range. The longer boom allows the operator to perform more lifts without the use of a jib, reducing setup time and improving efficiency. A 69 ft (21.03 m) or a 95 ft (29.0 m) four-section boom is also available.
- **Overload Protection** – All National Cranes are equipped with overload protection:
  - New Graphical Load Moment Indicator (LMI) is standard on all Series 900H machines. The graphical LMI displays various real-time information about crane and truck operating conditions and includes work area definition system (WADS) and operating limits.
  - LMI display console is weatherproof.
  - 7" LCD color and polarized display is visible in full or low light.
  - All crane load lifting values are displayed simultaneously.
- **Easy Glide Boom Wear Pads** – Reduce the conditions that cause boom chatter and vibration. The net result is smoother crane operation.
- **“HO”-style Outriggers** – Two sets of “HO”-style outriggers with 20 ft (6.09 m) span, with 14 ft (4.27 m) mid span setting with manual locks and reduced capacity chart and fully retracted outrigger spread with reduced capacity chart. Main outriggers are equipped with removable ball and socket aluminum foot pads. Independent outrigger controls (umbilical design) are located at the Easy Reach control console and includes level indicator (sight bubble).
- **Rotation** – The series 900H is standard with 410° non-continuous rotation.
- **Adjustable Swing Speed** – Standard on the 900H. A control knob located on the swing motor brake release valve can be easily adjusted to the crane operator’s swing speed preference.
- **Heavier-duty Torsion Box** – The stronger standard torsion box improves rigidity, reduces truck frame flex and reduces the need for counterweight.
- **Speedy-reeve Boom Tip and Sheave Blocks** – These standard features simplify rigging changes by decreasing the time needed to change line reeving.
- **Two Speed Winch** – Provides faster winch payout and pickup of unloaded cable.
- **Pre-painted Components** – Painting crane components before assembly reduces the possibility of rust, improves serviceability and enhances the appearance of the machine.
- **Improved Serviceability** –
  - Bearings on the boom extend and retract cables can be greased through access holes in the boom side plates.
  - Number of internal boom parts has been reduced, decreasing service time when rebuilding the machine.
  - Internal anti-two-block wire routing eliminates damage potential.
- **Electronic versions of manuals available through Manitowoc Crane CARE.**
- **New State-of-the-art Control Valve** – Provides smoother operation. The new design eliminates parts, reducing repair costs and improving the machine’s serviceability.
- **National Crane Is the Market Leader** – National Crane is number one in the production of commercial truck-mounted boom trucks and has many programs and people directly and indirectly involved to provide our customers with reliable products.
  - National Crane has the boom truck industry’s leading test program. Every structural part of the crane is cycle tested up to 60,000 cycles at full capacity. In addition to cycle testing, each model is subjected to state-of-the-art strain gauge testing that measures metal deformation as small as one one-millionth of an inch. The net result is that any weak areas are caught in test, not on job sites where costly downtime occurs.
  - Lift and telescoping cylinders are manufactured by National Crane, so that the seals, packing glands, and end plates are traced for accurate shipment of replacement parts.
  - Parts are available for all National Crane models for the life of the crane.
  - National Crane has a formalized quality program and is ISO 9001 approved.
- **National Crane’s Quality Management System is ISO 9001:2000 Approved.**

- 27 USt (24.5 t) maximum capacity
- 158 ft (48.2 m) w/optional jib maximum vertical reach\*
- 114 ft (34.7 m) maximum vertical hydraulic reach\*
- Graphical Load Moment Indicator system (LMI)
- Proportional boom extension
- High performance planetary winch
- Heavy-duty Load Sensing Piston Pump Hydraulics
- \* Maximum vertical reach is ground-level to boom tip height at maximum extension and angle with outriggers/stabilizers fully extended.

900H  
006

# mounting configuration

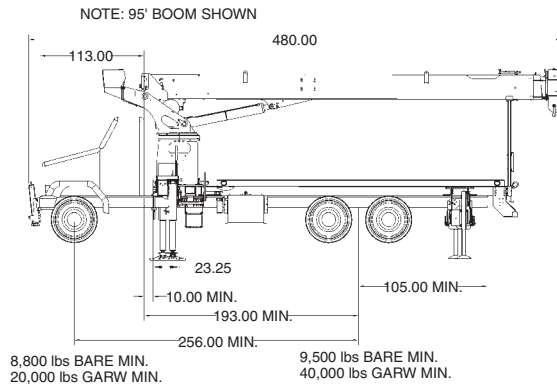
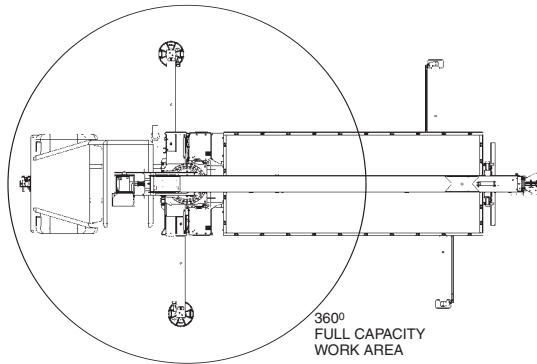

3

The mounting configuration is based on an 85% stability factor. If the bare truck weight requirements are not met, counterweight will be required. The complete unit must be installed on the truck in accordance with factory requirements. Since individual truck chassis vary, a test must be performed on the unit to verify actual stability after mounting and counter-weighting (if required). A summary of mounting and truck requirements are:

#### For 180 degree working area –

Gross Axle Weight Rating Front (GAWR) – 20,000 lb (9 072 kg)  
 Gross Axle Weight Rating Rear (GAWR) – 40,000 lb (18 144 kg)  
 Gross Vehicle Weight Rating (GVW) – 60,000 lb (27 216 kg)  
 Wheelbase (WB) – 256 in (6.50m)  
 Cab to Axle Trunnion (CT) – 193 in (4.90m)  
 After Frame (AF) – 105 in (2.67m) min.  
 Frame Section Modulus (SM) from outrigger to RSOD – 20 in<sup>3</sup> (327cm<sup>3</sup>) and 110,000 psi (759 MPa) material  
 Bare Chassis Weight required for stability prior to installation  
 Front – 8,880 lb (3 992 kg)  
 Rear – 9,500 lb (4 309 kg)

#### For 360 degree working area –

Optional Single Front Stabilizer (SFO)  
 Gross Axle Weight Rating Front (GAWR) – 20,000 lb (9 072 kg)  
 Gross Axle Weight Rating Rear (GAWR) – 40,000 lb (18 144 kg)  
 Gross Vehicle Weight Rating (GVW) – 60,000 lb (27 216 kg)  
 Wheelbase (WB) – 256 in (6.50m)  
 Cab to Axle Trunnion (CT) – 193 in (4.90m)  
 After Frame (AF) – 105 in (2.67m) min.  
 Frame Section Modulus (SM) from front spring hanger to end of after frame – 20 in<sup>3</sup> (327cm<sup>3</sup>) and 110,000 psi (759 MPa) material  
 Bare Chassis Weight required for stability prior to installation  
 Front – 8,800 lb (3 992 kg)  
 Rear – 9,500 lb (4 309 kg)

Note: Chassis will require extended front frame rails for SFO addition.

For 360° stability the truck frame must have a 20.0 in<sup>3</sup> (327 cm<sup>3</sup>) section modulus [2,200,000 in-lb (248,566 N-m) RBM] minimum under the crane frame, 15 in<sup>3</sup> (245 cm<sup>3</sup>) section modulus [1,650,000 in-lb (186,424 N-m) RBM] at the front spring rear hanger, 10 in<sup>3</sup> (163 cm<sup>3</sup>) section modulus [1,100,000 in-lb (124,283 N-m) RBM] through the front spring and 3 in<sup>3</sup> (49 cm<sup>3</sup>) section modulus [330,000 in-lb (37,284 N-m) RBM] at the stabilizer attachment point on each truck frame rail.

NOTE 1: Gross Vehicle Weight Rating (GVWR) is dependent on all components of the vehicle (axles, tires, springs, fame, etc.) meeting manufacturers' recommendations; always specify GVWR when purchasing trucks.

NOTE 2: Diesel engines require a variable speed governor and energize-to-run fuel solenoid for smooth crane operation; electronic fuel injection is required.

NOTE 3: All mounting data is based on a National Series 900H with subbase and an 85% stability factor.

NOTE 4: The complete unit must be installed in accordance with factory requirements, and a test performed to determine actual stability and counterweight requirements; contact the factory for details.

NOTE 5: Transmission neutral safety interlock switch is required.

H006

# specifications

## Boom and Jib Combinations Data

AVAILABLE IN THREE BASIC MODELS.

4

**Model 969H** — Equipped with a 22 to 69 ft (6.7-21.03 m) four-section boom. Maximum tip height is 78 ft (23.77 m).

22-69 ft (6.7-21.05 m) four-section boom.



**Model 995H** — Equipped with a 29 to 95 ft (8.83-29.0 m) four-section boom. This model can be equipped with a 25-44 ft (7.62-13.41 m) two section jib. Maximum tip height w/44 ft (13.41 m) jib is 153 ft (44.63 m).

29-95 ft (8.83-29.0 m) four-section boom.

**13FJ44M** 25-44 ft (7.62-13.41 m) two-section jib



**Model 9105H** — Equipped with a 33 to 105 ft (10.05-32.0 m) four-section boom. This model can be equipped with a 25-44 ft (7.62-13.41 m) two-section jib. Maximum tip height w/44 ft (13.41 m) jib is 163 ft (49.68 m).

33-105 ft (10.05-32.0 m) four-section boom.







**13FJ44M** 25-44 ft (7.62-13.41 m) two-section jib



**Note:** Maximum tip height is measured with outriggers/stabilizers fully extended.

## 900H Winch Data

- Do not deadhead line block against boom tip when extending boom.
- Keep at least 3 wraps of loadline on drum at all times.
- Use only 9/16 in diameter rotation-resistant cable with 38,500 pounds breaking strength on this machine.

			1 Part Line	2 Part Line	3 Part Line	4 Part Line	5 Part Line	6 Part Line	7 Part Line
									
MAXIMUM BOOM LENGTH AT MAXIMUM ELEVATION WITH RIGGING SHOWN WITH LOAD BLOCK AT GROUND LEVEL			69 ft boom	69 ft	69 ft	61 ft	51 ft	31 ft	21 ft
			139 ft boom & jib	95 ft	82 ft	56 ft	29 ft	29 ft	29 ft
			149 ft boom & jib	105 ft	90 ft	76 ft	32 ft	32 ft	32 ft
Winch	Average Cable Supplied	Breaking Strength	Lift and Speed	Lift and Speed	Lift and Speed	Lift and Speed	Lift and Speed	Lift and Speed	Lift and Speed
Standard Planetary Winch	9/16 in Diameter Rotation Resistant	38,500 lb (17 464 kg)	7,700 lb (3493 kg) 145 fpm (50 m/min)	15,400 lb (6986 kg) 73 fpm (25 m/min)	23,100 lb (10 478 kg) 48 fpm (16 m/min)	30,800 lb (13 971 kg) 36 fpm (12 m/min)	38,500 lb (17 464 kg) 29 fpm (10 m/min)	46,200 lb (20 956 kg) 24 fpm (8 m/min)	53,900 lb (24 449 kg) 21 fpm (7 m/min)
High Speed	9/16 in Diameter Rotation Resistant	38,500 lb (17 464 kg)	3,000 lb (1361 kg) 290 fpm (111 m/min)	6,000 lb (2722 kg) 145 fpm (40 m/min)	9,000 lb (4083 kg) 97 fpm (27 m/min)	12,000 lb (5443 kg) 73 fpm (20 m/min)	15,000 lb (6804 kg) 58 fpm (16 m/min)	18,000 lb (8 165 kg) 48 fpm (13 m/min)	21,000 lb (9 526 kg) 41 fpm (11 m/min)

All winch pulls and speeds in this chart are shown on the fourth layer. Winch line pulls would increase on the first, second and third layers. Winch line speed would decrease on the first, second and third layers. Winch line pulls may be limited by the winch capacity or the ANSI 5 to 1 cable safety factor. These are shown below:

Winch	4th Layer Drum Pull	Allowable Cable Pull
Standard planetary	7,700 lb (3493 kg) (low speed) 3,000 lb (1361 kg) ("burst of speed")	7,700 lb (3492 kg)

Block Type	Rating	Weight
Downhaul Weight	5 USt (4.53t)	150 lb (68 kg)
1 Sheave Block	12 USt (10.89t)	305 lb (139 kg)
2 Sheave Block	19 USt (17.24t)	350 lb (159 kg)
3 Sheave Block	30 USt (27.22t)	575 lb (261 kg)

900H

# capacities

## Load Rating Chart: Series 995H (29.0 m) Boom with 25-44 ft (7.62 m-13.41 m) Jib/Full-Span Outrigger & Stabilizer

Other Series 900H Load Rating Charts are available. National Crane will send you a chart on request – or you may secure needed load rating information through your nearest National Crane dealer.

**CAUTION:**

- Do not operate crane booms, jib extensions, any accessories or loads within 10 ft (3m) of live power lines or other conductors of electricity.
- Jib and boom capacities shown are maximum for each section.
- Do not exceed capacities at reduced radii.
- Load ratings shown on the appropriate charts are maximum allowable loads with the crane mounted on a factory-approved truck and all outriggers at either full span or at mid span range and set on a firm level surface so that the crane is level and all tires are suspended.
- Always level the crane with the level indicator located on the crane.
- The operator must reduce load to allow for factors such as wind, ground conditions, operating speeds and their effects on freely suspended loads.
- Overloading this crane may cause structural collapse or instability.
- Weights on any accessories attached to the boom or loadline must be deducted from the load chart capacities.
- Do not exceed jib capabilities at any reduced boom lengths.
- Do not deadhead lineblock against boom tip when extending boom or winching up.
- Keep at least three wraps of loadline on drum at all times.
- Use only specified cable with this machine.

**SERIES 995H  
(29.0 M) BOOM  
WITH 25-44 ft  
(7.62 M-13.41 M)  
JIB/FULL-SPAN  
OUTRIGGER &  
STABILIZER**

**NOTE:**

1. Operate with jib by radius when main boom is fully extended. If necessary increase boom angle to maintain loaded radius.
2. Operate with jib by boom angle when main boom is not fully extended. Do not exceed rated jib capacities at any reduced boom lengths.

**LOADLINE EQUIPMENT  
DEDUCT**

- Downhaul weight.....150 lb (68 kg)
- One sheave block .....305 lb (139 kg)
- Two sheave block.....350 lb (159 kg)
- Three sheave block.....575 lb (261 kg)

## Load Rating Chart: Series 995H (29.0 m) Boom with 25-44 ft (7.62 m-13.41 m) Jib/Full-Span Outrigger & Stabilizer

LOADED RADIUS (FT)	LOADED BOOM ANGLE (DEG)	29 FT BOOM (LB)	LOADED BOOM ANGLE (DEG)	42 FT BOOM (LB)	LOADED BOOM ANGLE (DEG)	55 FT BOOM (LB)	LOADED BOOM ANGLE (DEG)	69 FT BOOM (LB)	LOADED BOOM ANGLE (DEG)	82 FT BOOM (LB)	LOADED BOOM ANGLE (DEG)	95 FT BOOM (LB)
5	75.83	54,000										
8	69.50	42,000	76.66	29,000								
10	65.14	35,500	73.87	27,000								
12	60.60	31,750	71.04	25,000	75.87	28,000						
14	55.86	25,500	68.15	23,000	73.73	24,000	78.62	22,000				
16	50.80	23,000	65.19	21,000	71.55	22,000	77.06	18,000				
20	39.29	17,500	59.03	17,500	67.10	18,000	73.92	17,000	77.54	16,500		
25	17.36	13,000	50.67	13,250	61.31	13,500	69.90	13,000	74.25	13,250	75.85	12,000
30			41.11	10,500	55.14	10,500	65.73	10,250	70.77	10,500	72.73	10,500
35			29.07	8,250	48.46	8,500	61.43	8,250	67.60	8,250	69.33	8,500
40					41.65	7,000	57.32	6,750	64.03	6,750	66.17	7,000
45					32.91	5,750	52.58	5,500	60.30	5,500	62.61	5,750
50					21.15	4,750	47.51	4,500	56.35	4,500	58.94	4,750
55							41.97	3,700	52.28	3,750	55.15	4,000
60							35.73	2,950	47.90	3,000	51.13	3,250
65							28.32	2,300	43.19	2,500	46.82	2,600
70									38.02	2,000	42.25	2,000
75									32.16	1,600	37.19	1,500
80											31.53	1,250
85											24.66	1,000
90											14.66	500
	0.0	9,000	0.0	5,500	0.0	3,500	0.0	1,250	0.0	500		

25 - 44 ft JIB RATED LOADS				
LOADED RADIUS (FT)	LOADED BOOM ANGLE (DEG)	25 FT JIB (LB)	LOADED BOOM ANGLE (DEG)	44 FT JIB (LB)
25	79.01	4,900		
30	76.92	4,750		
35	74.74	4,500	76.98	2,500
40	72.37	4,000	75.20	2,500
45	69.90	3,500	73.38	2,500
50	67.64	3,500	71.54	2,500
55	64.99	3,000	69.66	2,500
60	62.40	2,750	67.51	2,300
65	59.71	2,500	65.40	2,200
70	56.71	2,000	63.22	2,100
75	53.64	1,800	60.97	2,000
80	50.41	1,200	58.42	1,750
85	47.02	850	55.62	1,400
90	43.50	600	52.75	1,100
95			49.81	850
100			46.55	500

\*SHADED AREAS ARE STRUCTURALLY LIMITED CAPACITIES

THIS CHART IS ONLY A GUIDE AND SHOULD NOT BE USED TO OPERATE THE CRANE. The individual crane's load chart, operating instructions and other instructional plates must be read and understood prior to operating the crane.

# capacities

6

## Load Rating Chart: Series 995H (29.0 m) Boom with 25-44 ft (7.62 m-13.41 m) Jib/Mid-Span Outrigger & Stabilizer

Other Series 900H Load Rating Charts are available. National Crane will send you a chart on request – or you may secure needed load rating information through your nearest National Crane dealer.

### CAUTION:

- Do not operate crane booms, jib extensions, any accessories or loads within 10 ft (3m) of live power lines or other conductors of electricity.
- Jib and boom capacities shown are maximum for each section.
- Do not exceed capacities at reduced radii.
- Load ratings shown on the load rating charts are maximum allowable loads with the outriggers properly extended and the outrigger lock pins engaged on a firm, level surface and the crane leveled and mounted on a factory recommended truck.
- Always level the crane with the level indicator located on the crane.
- The operator must reduce load to allow for factors such as wind, ground conditions, operating speeds and their effects on freely suspended loads.
- Overloading this crane may cause structural collapse or instability.
- Weights on any accessories attached to the boom or loadline must be deducted from the load chart capacities.
- Do not exceed jib capabilities at any reduced boom lengths.
- Do not deadhead lineblock against boom tip when extending boom or winching up.
- Keep at least three wraps of loadline on drum at all times.
- Use only specified cable with this machine.

**SERIES 995H  
(29.0 M) BOOM  
WITH 25-44 ft  
(7.62 M-13.41 M)  
JIB/MID-SPAN  
OUTRIGGER  
STABILIZER**

### NOTE:

1. Operate with jib by radius when main boom is fully extended. If necessary increase boom angle to maintain loaded radius.
2. Operate with jib by boom angle when main boom is not fully extended. Do not exceed rated jib capacities at any reduced boom lengths.

### LOADLINE EQUIPMENT DEDUCT

Downhaul weight.....150 lb (68 kg)  
One sheave block .....305 lb (139 kg)  
Two sheave block.....350 lb (159 kg)  
Three sheave block.....575 lb (261 kg)

## Load Rating Chart: Series 995H (29.0 m) Boom with 25-44 ft (7.62 m-13.41 m) Jib/Mid-Span Outrigger & Stabilizer

LOADED RADIUS (FT)	LOADED BOOM ANGLE (DEG)	29 ft BOOM (LB)	LOADED BOOM ANGLE (DEG)	A		B		C		D		95 ft BOOM (LB)
				42 ft BOOM (LB)	BOOM ANGLE (DEG)	55 ft BOOM (LB)	BOOM ANGLE (DEG)	69 ft BOOM (LB)	BOOM ANGLE (DEG)	82 ft BOOM (LB)	BOOM ANGLE (DEG)	
5	75.83	54,000										
8	69.50	42,000	76.7	29,000								
10	65.14	35,500	73.9	27,000								
12	60.60	31,750	71.0	25,000	75.9	28,000						
14	55.86	25,500	68.1	23,000	73.8	24,000	77.6	22000				
16	50.80	23,000	65.2	21,000	71.6	22,000	75.8	18000				
20	39.32	13,400	59.0	17,500	67.1	18,000	72.4	17000	76.2	16500		
25	17.41	8,500	50.6	9,000	61.2	9,200	67.6	9350	72.0	9500	75.9	12000
30			41.9	6,250	55.6	6,400	63.2	6550	68.4	6650	72.2	6750
35			30.2	4,500	48.9	4,700	58.3	4850	64.4	4950	68.8	5050
40					41.5	3,450	53.0	3550	60.3	3650	65.3	3750
45					32.8	2,500	47.5	2600	56.0	2700	61.8	2800
50					21	1800	41.4	1900	51.5	2000	58.1	2050
55								34.4	1350	46.7	1400	1500
60								25.8	850	41.5	950	1000
65								13	500	36	550	600
	0	9000	0	3,100	0	1,350						

25 - 44 ft JIB RATED LOADS				
LOADED RADIUS (FT)	LOADED BOOM ANGLE (DEG)	25 ft jib 95 ft BOOM (LB)	LOADED BOOM ANGLE (DEG)	44 ft jib 95 ft BOOM (LB)
25	79.0	4900		
30	76.9	4750		
35	74.7	4500	77.0	2500
40	72.4	4000	75.2	2500
45	69.9	3500	73.4	2500
50	66.7	1850	71.5	2500
55	63.9	1,200	69.7	2,500
60	61.1	750	66.5	1,350
65			63.9	900
70			61.3	550

\*SHADED AREAS ARE STRUCTURALLY LIMITED CAPACITIES

THIS CHART IS ONLY A GUIDE AND SHOULD NOT BE USED TO OPERATE THE CRANE. The individual crane's load chart, operating instructions and other instructional plates must be read and understood prior to operating the crane.

900H

# capacities

7

## Load Rating Chart: Series 9105H (29.0 m) Boom with 25-44 ft (7.62 m-13.41 m) Jib/Full-Span Outrigger & Stabilizer

Other Series 900H Load Rating Charts are available. National Crane will send you a chart on request – or you may secure needed load rating information through your nearest National Crane dealer.

**CAUTION:**

- Do not operate crane booms, jib extensions, any accessories or loads within 10 ft (3m) of live power lines or other conductors of electricity.
- Jib and boom capacities shown are maximum for each section.
- Do not exceed capacities at reduced radii.
- Load ratings shown on the appropriate charts are maximum allowable loads with the crane mounted on a factory-approved truck and all outriggers at either full span or at mid span range and set on a firm level surface so that the crane is level and all tires are suspended.
- Always level the crane with the level indicator located on the crane.
- The operator must reduce load to allow for factors such as wind, ground conditions, operating speeds and their effects on freely suspended loads.
- Overloading this crane may cause structural collapse or instability.
- Weights on any accessories attached to the boom or loadline must be deducted from the load chart capacities.
- Do not exceed jib capabilities at any reduced boom lengths.
- Do not deadhead lineblock against boom tip when extending boom or winching up.
- Keep at least three wraps of loadline on drum at all times.
- Use only specified cable with this machine.

**SERIES 9105H  
(29.0 M) BOOM  
WITH 25-44 ft  
(7.62 M-13.41 M)  
JIB/FULL-SPAN  
OUTRIGGER &  
STABILIZER**

**NOTE:**

1. Operate with jib by radius when main boom is fully extended. If necessary increase boom angle to maintain loaded radius.
2. Operate with jib by boom angle when main boom is not fully extended. Do not exceed rated jib capacities at any reduced boom lengths.

**LOADLINE EQUIPMENT  
DEDUCT**

Downhaul weight.....150 lb (68 kg)  
One sheave block .....305 lb (139 kg)  
Two sheave block.....350 lb (159 kg)  
Three sheave block.....575 lb (261 kg)

## Load Rating Chart: Series 9105H (29.0 m) Boom with 25-44 ft (7.62 m-13.41 m) Jib/Full-Span Outrigger & Stabilizer

LOADED RADIUS (ft)	LOADED BOOM ANGLE (deg)	32 ft BOOM (lb)	LOADED BOOM ANGLE (deg)	A		B		C		D		LOADED BOOM ANGLE (deg)	105 ft BOOM (lb)	25 - 44 ft JIB RATED LOADS					
				46 ft BOOM (lb)	LOADED BOOM ANGLE (deg)	61 ft BOOM (lb)	LOADED BOOM ANGLE (deg)	76 ft BOOM (lb)	LOADED BOOM ANGLE (deg)	90 ft BOOM (lb)	LOADED BOOM ANGLE (deg)			LOADED RADIUS (ft)	LOADED BOOM ANGLE (deg)	25 ft JIB (lb)	LOADED BOOM ANGLE (deg)	44 ft JIB (lb)	
5	77.2	54,000												30					
8	71.5	40,000	77.6	29,000										35					
10	67.6	34,000	75.0	27,000										40	73.9	4,400			
12	63.5	30,000	72.4	24,950	77.4	24,000								45	71.9	4,400	74.7	2,800	
14	59.4	24,000	69.7	22,850	75.4	22,000	78.6	19,000						50	69.6	4,100	72.9	2,700	
16	55.0	22,000	67.0	20,450	73.5	20,000	77.1	17,000						55	67.2	3,600	71.1	2,650	
20	45.4	16,500	61.3	16,950	69.4	16,000	73.9	14,500	77.5	13,000				60	64.5	2,850	69.2	2,500	
25	30.2	12,000	53.8	12,900	64.2	13,000	69.9	12,000	74.3	11,000	77.5	10,000		65	61.7	2,250	67.1	2,300	
30			45.4	10,000	58.7	10,000	65.7	9,500	70.8	8,750	74.7	9,000		70	58.9	1,750	65.1	2,200	
35			35.5	7,750	52.9	8,000	61.4	8,000	67.6	7,500	72.1	8,500		75	56.0	1,300	62.8	1,950	
40			23.3	6,300	47.1	6,650	57.3	6,750	64.0	6,500	69.2	7,100		80	53.1	900	60.2	1,550	
45					39.8	5,300	52.6	5,500	60.3	5,500	66.1	5,800		85	50.0	550	57.5	1,150	
50					31.5	4,300	47.5	4,550	56.4	4,450	62.8	4,850		90			54.8	850	
55					20.3	3,500	42.0	3,700	52.3	3,850	59.5	3,950		95			52.0	3,950	
60							35.7	2,950	47.9	3,100	56.0	3,200		100					
65							28.3	2,300	43.2	2,500	52.4	2,600		105					
70							18.3	1,800	38.0	2,000	48.6	2,100							
75									32.2	1,600	44.6	1,650							
80									25.0	1,200	40.3	1,300							
85									14.8	850	35.5	950							
90											30.1	650							
95																			
100																			
	0	8000	0	4500	0	2500	0	1300	0	500									

\*SHADED AREAS ARE STRUCTURALLY LIMITED CAPACITIES

THIS CHART IS ONLY A GUIDE AND SHOULD NOT BE USED TO OPERATE THE CRANE. The individual crane's load chart, operating instructions and other instructional plates must be read and understood prior to operating the crane.

**9006**

# capacities

8

## Load Rating Chart: Series 9105H (29.0 m) Boom with 25-44 ft (7.62 m-13.41 m) Jib/Mid-Span Outrigger & Stabilizer

Other Series 900H Load Rating Charts are available. National Crane will send you a chart on request – or you may secure needed load rating information through your nearest National Crane dealer.

**CAUTION:**

- Do not operate crane booms, jib extensions, any accessories or loads within 10 ft (3m) of live power lines or other conductors of electricity.
- Jib and boom capacities shown are maximum for each section.
- Do not exceed capacities at reduced radii.
- Load ratings shown on the load rating charts are maximum allowable loads with the outriggers properly extended and the outrigger lock pins engaged on a firm, level surface and the crane leveled and mounted on a factory recommended truck.
- Always level the crane with the level indicator located on the crane.
- The operator must reduce load to allow for factors such as wind, ground conditions, operating speeds and their effects on freely suspended loads.
- Overloading this crane may cause structural collapse or instability.
- Weights on any accessories attached to the boom or loadline must be deducted from the load chart capacities.
- Do not exceed jib capabilities at any reduced boom lengths.
- Do not deadhead lineblock against boom tip when extending boom or winching up.
- Keep at least three wraps of loadline on drum at all times.
- Use only specified cable with this machine.

**SERIES 9105H  
(29.0 M) BOOM  
WITH 25-44 ft  
(7.62 M-13.41 M)  
JIB/MID-SPAN  
OUTRIGGER  
STABILIZER**

**NOTE:**

1. Operate with jib by radius when main boom is fully extended. If necessary increase boom angle to maintain loaded radius.
2. Operate with jib by boom angle when main boom is not fully extended. Do not exceed rated jib capacities at any reduced boom lengths.

**LOADLINE EQUIPMENT DEDUCT**  
 Downhaul weight.....150 lb (68 kg)  
 One sheave block .....305 lb (139 kg)  
 Two sheave block.....350 lb (159 kg)  
 Three sheave block.....575 lb (261 kg)

## Load Rating Chart: Series 9105H (29.0 m) Boom with 25-44 ft (7.62 m-13.41 m) Jib/Mid-Span Outrigger & Stabilizer

LOADED RADIUS (ft)	LOADED BOOM ANGLE (deg)	32 ft BOOM (lb)	LOADED BOOM ANGLE (deg)	A 46 ft BOOM (lb)	LOADED BOOM ANGLE (deg)	B 61 ft BOOM (lb)	LOADED BOOM ANGLE (deg)	C 76 ft BOOM (lb)	LOADED BOOM ANGLE (deg)	D 90 ft BOOM (lb)	LOADED BOOM ANGLE (deg)	105 ft BOOM (lb)
5	77.2	54,000										
8	71.5	40,000	77.6	29,000								
10	67.6	34,000	75.0	27,000								
12	63.5	30,000	72.4	24,950	77.4	24,000						
14	59.4	24,000	69.7	22,850	75.4	22,000	78.6	19,000				
16	55.0	18,000	67.0	20,450	73.5	20,000	77.1	17,000				
20	45.4	12,500	61.3	13,150	69.4	16,000	73.9	14,500	77.5	13,000		
25	31.8	7,700	53.7	8,350	63.8	8,700	69.7	8,900	74.3	11,000	77.5	10,000
30			46.1	5,700	58.8	5,900	65.8	6,100	70.7	6,350	74.4	6,500
35			36.3	3,900	53.0	4,250	61.5	4,400	67.1	4,600	71.3	4,750
40			23.3	2,650	46.7	2,950	57.0	3,150	63.4	3,300	68.1	3,450
45					39.7	2,050	52.3	2,200	59.6	2,350	65.0	2,500
50					31.4	1,350	47.2	1,500	55.7	1,650	61.7	1,750
55					20.1	750	41.6	950	51.5	1,050	58.4	1,150
60							35.4	500	47.2	600	55.0	700
65												
70												
75												
80												
85												
90												
	0	5,200	0	1,950								

25 - 44 ft JIB RATED LOADS				
LOADED RADIUS (ft)	LOADED BOOM ANGLE (deg)	25 ft jib 100 ft BOOM (lb)	LOADED BOOM ANGLE (deg)	44 ft jib 100 ft BOOM (lb)
40	73.9	4,400		
45	70.7	2,250		
50	68.0	1,450	72.9	2,700
55	65.4	850	70.0	1,550
60			67.5	1,000
65			65.1	550
70				
75				
80				

\*SHADED AREAS ARE STRUCTURALLY LIMITED CAPACITIES

THIS CHART IS ONLY A GUIDE AND SHOULD NOT BE USED TO OPERATE THE CRANE. The individual crane's load chart, operating instructions and other instructional plates must be read and understood prior to operating the crane.

900H



## Radio Remote Control –

Four-function radio remote control for standard unit and 6-function remotes with auger.

• **NB6R**

## Steel Bulkhead

• **BHSD**

## Outrigger Motion Alarms –

Available for HO outriggers and RSOD stabilizers.

• **OMA-2**

## Steel Tool Box Options

### Spanish-Language Danger Decals, Control Knobs, and Operators' Manuals

• **SDD**

• **SOM**

## One-Person Basket –

Strong but lightweight steel basket with 300 lb (139 kg) capacity, gravity hung with swing lock and full body harness.

• **B1-S**

• **2B1-S** (for dual locking baskets)

## Heavy-duty Personnel Basket –

1,200 lb (544 kg) capacity steel basket with safety loops for four passengers. Gravity leveling 72 x 42 inch (183 x 107 cm) platform. Fast attachment and secure locking systems. Load chart must show 2,300 lb (1043 kg) minimum to operate this accessory.

• **BSA-1**

• **BSA-R1** (provides rotation)

## Winch Drum Rotation Indicator

• **WDRI**

**Last Wrap Indicator Option** on winch with indicator on Easy Reach console.

• **LLI**

## Auger Option 95-ft. Boom Only

14,000 ft/lb two speed auger  
Max digging radius 39 ft

## Oil Cooler

Oil coolers recommended for duty cycle applications

• **OC**

# dimensions specifications

10

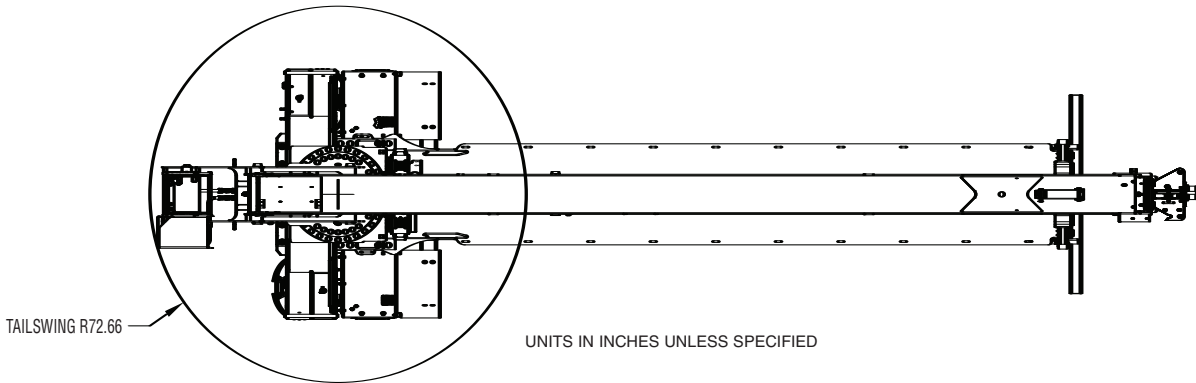

UNITS IN INCHES UNLESS SPECIFIED

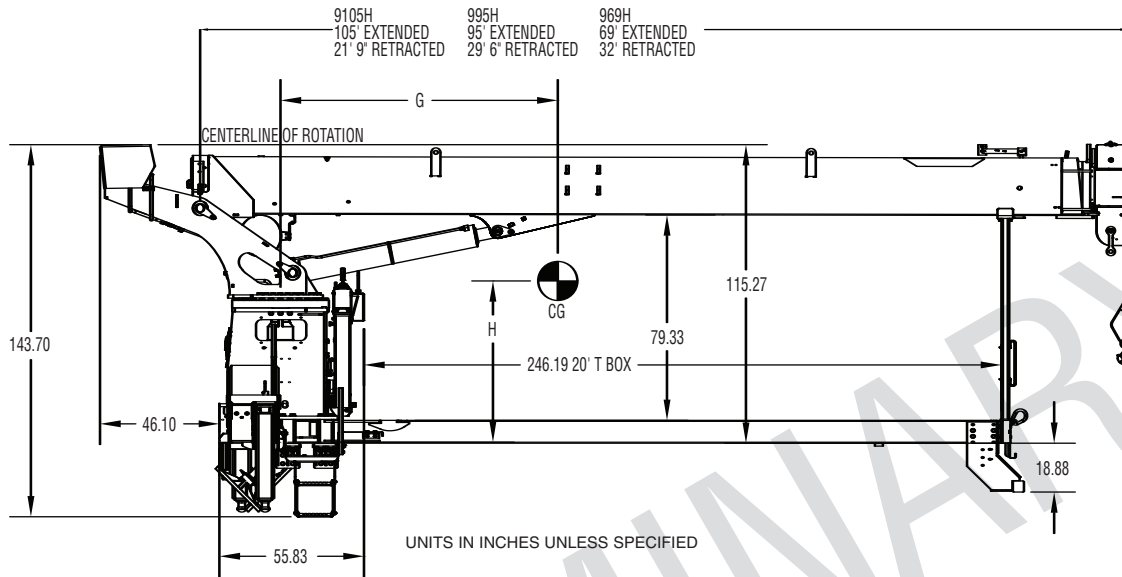

UNITS IN INCHES UNLESS SPECIFIED

WEIGHT AND CENTERS OF GRAVITY INCLUDES BOOM, WINCH, ROPE, TURRET, LIFT CYLINDER, FRAME, CONTROLS, OUTRIGGERS, PLATFORMS, TORQUE BOX, BOOM REST, BUMPER, DOWNHAUL WEIGHT

	G	H	WEIGHT*
969H	66.9 in	53.7 in	18,206 lb
995H	95.4 in	59.2 in	20,352 lb
9105H	104.9 in	60.6 in	21,090 lb

\*ABOVE WEIGHTS AND CENTERS OF GRAVITY DO NOT INCLUDE RESERVOIR, RSOD, JIB, PTO, PUMP, BED SFO

	THRUST	MOMENT
MAX THRUST CASE	65,537 LB	3,280,362 LB-IN
MAX MOMENT CASE	21,530 LB	5,038,990 LB-IN

OVERALL TURNABLE TORQUE 595,354 LB-IN  
 BRAKE TORQUE 3,363 LB-IN\*\*  
 PINION TORQUE 82,336.59 LB-IN\*\*

\*\*USING NATIONAL GEARBOX

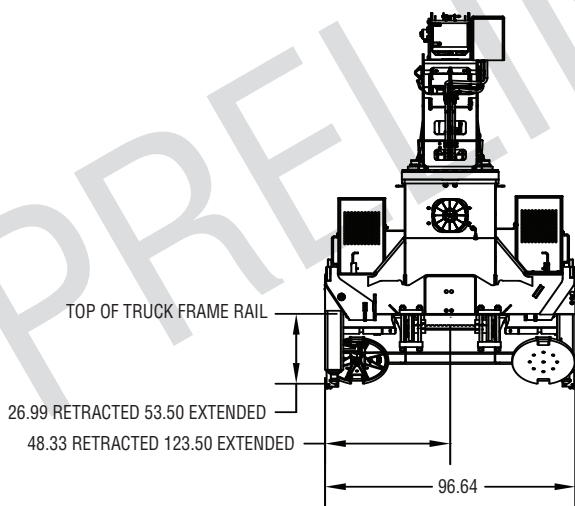

UNITS IN INCHES UNLESS SPECIFIED

900H



## **Regional Headquarters**

### **Americas**

Manitowoc, Wisconsin, USA

Tel: +1 920 684 6621

Fax: +1 920 683 6278

Shady Grove, Pennsylvania, USA

Tel: +1 717 597 8121

Fax: +1 717 597 4062

## **Regional Offices**

### **Americas**

#### **Brazil**

Alphaville

Tel: +55 11 3103 0200

Fax: +55 11 4688 2013

#### **Mexico**

Monterrey

Tel: +52 81 8124 0128

Fax: +52 81 8124 0129

### **Europe, Middle East, Africa**

#### **Algeria**

Hydra

Tel: +21 3 21 48 1173

Fax: +21 3 21 48 1454

#### **Czech Republic**

Netvorice

Tel: +420 317 78 9313

Fax: +420 317 78 9314

#### **France**

Baudemont

Tel: +33 385 28 2589

Fax: +33 385 28 0430

#### **Cergy**

Tel: +33 130 31 3150

Fax: +33 130 38 6085

#### **Decines**

Tel: +33 472 81 5000

Fax: +33 472 81 5010

#### **Germany**

Langenfeld

Tel: +49 21 73 8909-0

Fax: +49 21 73 8909 30

#### **Hungary**

Budapest

Tel: +36 13 39 8622

Fax: +36 13 39 8622

#### **Italy**

Parabiago

Tel: +390 331 49 3311

Fax: +390 331 49 3330

### **Europe, Middle East, Africa**

Ecully, France

Tel: +33 472 18 2020

Fax: +33 472 18 2000

#### **Netherlands**

Breda

Tel: +31 76 578 3999

Fax: +31 76 578 3978

#### **Poland**

Warsaw

Tel: +48 22 843 3824

Fax: +48 22 843 3471

#### **Portugal**

Alfena

Tel: +351 229 69 8840

Fax: +351 229 69 8848

Lisbon

Tel: +351 212 109 340

Fax: +351 212 109 349

#### **Russia**

Moscow

Tel: +7 495 641 2359

Fax: +7 495 641 2358

#### **U.A.E.**

Dubai

Tel: +971 4 3381 861

Fax: +971 4 3382 343

#### **U. K.**

Middlesex

Tel: +44 1 895 43 0053

Fax: +44 1 895 45 9500

Sunderland

Tel: +44 191 522 2000

Fax: +44 191 522 2052

### **Asia – Pacific**

#### **Australia**

Melbourne

Tel: +61 3 9 336 1300

Fax: +61 3 9 336 1322

Sydney

Tel: +61 2 9 896 4433

Fax: +61 2 9 896 3122

### **Asia – Pacific**

Shanghai, China

Tel: +86 21 51113579

Fax: +86 21 51113578

Singapore

Tel: +65 6264 1188

Fax: +65 6862 4142

#### **China**

Beijing

Tel: +86 10 58674761

Fax: +86 10 58674760

Xi'an

Tel: +86 29 87891465

Fax: +86 29 87884504

#### **Korea**

Seoul

Tel: +82 2 3439 0400

Fax: +82 2 3439 0405

#### **Philippines**

Makati City

Tel: +63 2 844 9437

Fax: +63 2 844 4712

#### **Factories**

Brazil

Alphaville

China

Zhangjiagang

France

Charlieu

La Clayette

Moulins

Germany

Wilhelmshaven

India

Calcutta

Pune

Italy

Niella Tanaro

Portugal

Baltar

Fânzeres

Slovakia

Saris

U.S.A.

Manitowoc

Port Washington

Shady Grove



Constant improvement and engineering progress make it necessary that we reserve the right to make specification, equipment and price changes without notice. Illustrations shown may include optional equipment and accessories, and may not include all standard equipment.