

Series **600E**

product guide

features

- **All New Design**
- **90' Four-Section Boom**
- **20 Ton Rating**
- **Self-lubricating "Easy Glide" Wear Pads**
- **Internal Anti-two-block**
- **Auxiliary Stabilizers**
- **Variable Displacement Hydraulic System**



contents

Features	2
Mounting Configurations	3
Specifications	4
Capacities: With 45' Jib	5
Capacities: No Jib	6
Accessories	7

features

Why Buy a National Series 600E?

2



- **20 ton Rating** – The new 600E provides a 20-ton capacity.
- **New 90 ft. Four-section Boom** – The longest in its size range. The longer boom allows the operator to perform more lifts without the use of a jib, reducing setup time and improving efficiency.
- **Self-lubricating “Easy glide” Wear Pads** – The self-lubricating pads, standard on the 600E reduce the conditions that cause boom chatter and vibration. The net result is smoother crane operation.
- **Internal Anti-two-block** – The patent-pending design, standard on the 600E eliminates the external reel and wire. No more snagging reel or wire on obstructions.
- **Adjustable Swing Speed** – A control knob located on the swing motor brake release valve can be easily adjusted to the crane operator’s swing speed preference.
- **Optional New Integral Steel Torsion Bedbox** – Integral welded torsion box and flatbed. Further reduces frame flex.
- **Auxiliary Stabilizers** –
 - Independent stabilizer control
 - Bolt/Clamp on rear stabilizers
- **Quick-reeve Boom Tip and Sheave Blocks** – These standard features simplify rigging changes.
- **Pre-painted Components** – Painting crane components before assembly reduces the possibility of rust, improves serviceability and enhances the appearance of the machine.
- **Burst-of-Speed Winch** – Provides faster winch payout and pickup of unloaded cable.
- **Improved Serviceability** –
 - A removable winch allows the internal telescoping cylinder to be removed quickly, without dismantling the boom.
 - Bearings on the boom extend and retract cables can be greased through access holes in the boom side plates.
 - Internal anti-two-block wire routing eliminates damage potential.
 - The boom sheave case is open, allowing access to replace the internal anti-two-block wire and to observe internal boom components.
 - Pre-paint reduces rust.
 - Internal boom parts have been reduced, decreasing service time when rebuilding the machine.
- **New State-of-the-Art Hydraulic System** – Provides smoothest operation in the market.
 - The hydraulic system features a control strategy of constant pressure, flow on demand to optimize performance. This control strategy matches the required flow to the demand (speed) of the function while the variable displacement piston pump is regulated to maintain a constant pressure to the eight section main valve. Because the pump pressure is constant, multi-function operation is very good, and precise, smooth metering is assured regardless of load.
 - Main valve spools are designed to both meter the flow and limit the maximum flow to each function. Available oil flow is optimized by using “gravity” for Boom down – no pump flow is necessary.
- **National Crane Is the Market Leader** – National is number one in the production of commercial truck-mounted boom trucks.
 - National has the boom truck industry’s leading test program. Every structural part of the crane is fully life cycle tested at full capacity. In addition to cycle testing, each model is subjected to state-of-the-art strain gauge testing that measures metal deformation as small as one-millionth of an inch. The net result is that weak areas are caught in test, not on job sites where costly downtime occurs.
 - All outrigger, lift and telescoping cylinders are manufactured to National Crane Designs, so that the seals, packing glands, and end plates are traced for accurate shipment of replacement parts.
 - National has a formalized quality program and is ISO 9001 approved.
- **National Crane Is a Quality Product That Will Provide Years of Service**
 - Parts are available for all National Crane machines, even if they are over 20 years old.

- 20-ton (18.1-t) maximum capacity
- 140 ft. (42.7 m) maximum vertical reach with jib*
- 100 ft. (30.5 m) maximum vertical hydraulic reach main boom*
- Hydraulic Capacity Alert system (HCA)
- Proportional boom extension
- High performance planetary winch
- Heavy-duty piston pump hydraulics
- * Maximum vertical reach is ground-level to boom tip height at maximum extension and angle with outriggers/stabilizers fully extended.

600E

mounting configurations

The configurations are based on the Series 600E with an 85% stability factor. The complete unit must be installed in accordance with factory requirements and a test performed to determine actual stability and counterweight requirements since individual truck chassis vary.

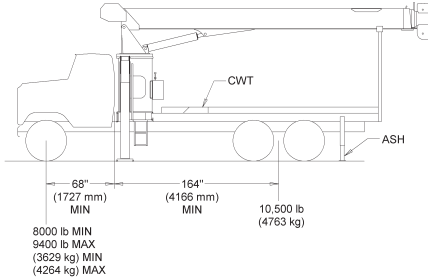

Configuration 1 with Torsion Box – 180° Full Capacity Work Area

Working area	180°
Gross Axle Weight Rating Front	14,000 lb (6350 kg)
Gross Axle Weight Rating Rear	34,000 lb (15,442 kg)
Gross Vehicle Weight Rating.....	48,000 lb (21,773 kg)
Wheelbase.....	232 in (589 cm)
Cab to Axle/trunnion (CA/CT).....	164 in (417 cm)
Frame Section Modulus (SM) under crane:	
110,000 PSI (758 MPa).....	15.9 in ³ (261 cm ³)
Frame Section Modulus (SM) over rear stabilizers:	
110,000 PSI (758 MPa).....	13 in ³ (213 cm ³)
Stability Weight, Front	8,000 lb (3629 kg) minimum*
Stability Weight, Rear.....	10,500 lb (4763 kg) minimum*
Estimated Average Final Weight	30,000 lb (13,608 kg)

3

This configuration is the least expensive method for the Model 600E. This mount, with the crane mounted behind the cab, requires the least weight of all mounts for stability; thus, you can haul larger payloads on your truck. It requires standard subbase and rear (ASH) stabilizers.

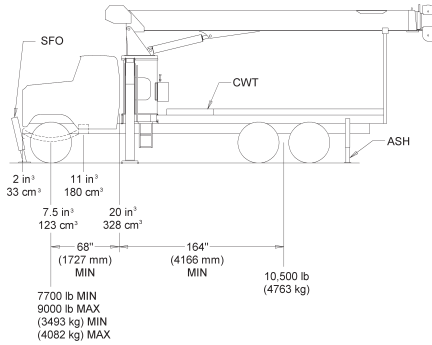

Configuration 2 with Torsion Box – 360° Full Capacity Work Area

Working area	360°
Gross Axle Weight Rating Front.....	14,000 lb (6350 kg)
Gross Axle Weight Rating Rear	34,000 lb (15,442 kg)
Gross Vehicle Weight Rating.....	48,000 lb (21,773 kg)
Wheelbase.....	232 in (589 cm)
Cab to Axle/trunnion (CA/CT).....	164 in (417 cm)
Frame Section Modulus (SM) under crane:	
110,000 PSI (758 MPa).....	20 in ³ (328 cm ³)
Frame Section Modulus (SM) over rear stabilizers:	
110,000 PSI (758 MPa).....	13 in ³ (213 cm ³)
Stability Weight, Front	7,700 lb (3130 kg) minimum*
Stability Weight, Rear.....	10,500 lb (3175 kg) minimum*
Estimated Average Final Weight	30,600 lb (13,879 kg)

Requires front SFO stabilizer to give machine full capacity 360° around the truck. Truck must meet the minimum requirements above. Front stabilizer gives the machine a solid base, helping the operator control loads precisely.

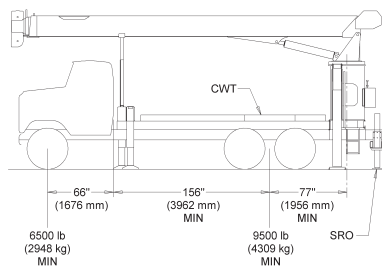

Configuration 3 with Torsion Box – Rear Mount

Working area	180°
Gross Axle Weight Rating Front.....	12,000 lb (5443 kg)
Gross Axle Weight Rating Rear	34,000 lb (15,442 kg)
Gross Vehicle Weight Rating.....	46,000 lb (20,865 kg)
Wheelbase.....	222 in (564 cm)
Cab to Axle/trunnion (CA/CT).....	156 in (396 cm)
Frame Section Modulus (SM) under crane:	
110,000 PSI (758 MPa).....	15.9 in ³ (261 cm ³)
Frame Section Modulus (SM) over rear stabilizers:	
110,000 PSI (758 MPa).....	15.9 in ³ (213 cm ³)
Stability Weight, Front	6,500 lb (3629 kg) minimum*
Stability Weight, Rear.....	9,500 lb (4763 kg) minimum*
Estimated Average Final Weight	28,750 lb (13,040 kg)

Allows the installation of the Model 600E on a chassis. In most cases, the chassis will not require reinforcing, and the amount of counterweight required is minimized, increasing payload capacities.

Notes:

- Gross Vehicle Weight rating (GVWR) is dependent on all components of the vehicle (axles, tires, springs, frame, etc.) meeting manufacturers' recommendations: always specify GVWR when purchasing trucks
- Diesel engines require a variable speed governor and energize-to-run fuel solenoid for smooth crane operation; electronic fuel injection requires EET engine remote throttle

- All mounting data is based on a National Series 600E with an 85 percent stability factor
- The complete unit must be installed in accordance with factory requirements, and a test performed to determine actual stability and counterweight requirements per SAE J765; contact the factory for details
- Transmission neutral safety interlock switch is required with optional remote control

*Estimated axle scale rates prior to installation of crane, stabilizers and subbase for 85% stability.

specifications

Boom and Jib Combinations Data

Available in five basic models.

4

Model 638E – Equipped with a 16-38 ft. (4.88-11.58 m) three-section boom. Maximum tip height is 48 ft. (14.63 m) (no jib option available).

16-38 ft. (4.88-11.58 m) three-section boom.



Model 647E – Equipped with 19-47 ft. (5.79-14.33 m) three-section boom. This model can be equipped with an 18-29 ft. (5.49-8.84 m) two section jib. Maximum tip height w/29 ft. (8.84 m) jib is 86 ft. (26.24 m).

19-47 ft. (5.79-14.33 m) three-section boom.



19-47 ft. (5.79-14.33 m) three-section boom.

6FJ29M 18-29 ft. (5.49-8.84 m) two-section jib



Model 671E – Equipped with a 27-71 ft. (8.23-21.64 m) three-section boom. This model can be equipped with a 25-45 ft. (7.62-13.72 m) two-section jib. Maximum tip height w/45 ft. (13.72 m) jib is 125 ft. (38.25 m).

27-71 ft. (8.23-21.64 m) three-section boom.



27-71 ft. (8.23-21.64 m) three-section boom.

6FJ45M 25-45 ft. (7.62-13.72 m) two-section jib



Model 680E – Equipped with a 24-80 ft. (7.32-24.38 m) four-section boom. Maximum tip height is 90 ft. (27.44 m). (no jib option available).

24-80 ft. (7.32-24.38 m) four-section boom.



Model 690E – Equipped with a 27-90 ft. (8.23-27.43 m) four-section boom. This model can be equipped with a 25-45 ft. (7.62-13.72 m) two section jib. Maximum tip height w/45 ft. (13.72 m) jib is 144 ft. (43.95 m).

27-90 ft. (8.23-27.43 m) four-section boom.



27-90 ft. (8.23-27.43 m) four-section boom.

6FJ45M 25-45 ft. (7.62-13.72 m) two-section jib



Note: Maximum tip is measured with outriggers/stabilizers fully extended.

600E Winch Data

600E Winch Data

- All winch pulls and speeds in this chart are shown on the fourth layer
- Winch line pulls would increase on the first and second layers
- Winch line pulls may be limited by the winch capacity or the ANSI 5 to 1 cable safety factor, shown below this chart
- Hook blocks are rated at maximum capacity for the block. **Do not exceed rated cable pull with any block.**

600E Winch Data			1 Part Line	2 Part Line	3 Part Line	4 Part Line	5 Part Line	6 Part Line
Winch	Cable Supplied	Average Breaking Strength	Lift and Speed	Lift and Speed	Lift and Speed	Lift and Speed	Lift and Speed	Lift and Speed
Standard Planetary Winch	9/16" Diameter Rotation Resistant	38,600 lb (17,463 kg)	7,700 lb (3,492.66 kg) 110 fpm (33.53 m/m)	15,400 lb (6,985.32 kg) 55 fpm (16.76 m/m)	23,100 lb (10,477.98 kg) 37 fpm (11.28 m/m)	30,800 lb (13,970.65 kg) 28 fpm (8.54 m/m)	38,500 lb (14,514.96 kg) 22 fpm (6.71 m/m)	40,000 lb (14,514.96 kg) 18 fpm (6.71 m/m)
Standard With "Burst-of-Speed"	9/16" Diameter Rotation Resistant	38,600 lb (17,463 kg)	7,700 lb (3,492.66 kg) 193 fpm (58.83 m/m)	15,400 lb (6,985.32 kg) 97 fpm (29.57 m/m)	23,100 lb (10,477.98 kg) 64 fpm (19.51 m/m)	30,800 lb (13,970.65 kg) 49 fpm (14.94 m/m)	38,500 lb (14,514.96 kg) 39 fpm (11.89 m/m)	40,000 lb (14,514.96 kg) 32 fpm (11.89 m/m)

Winch	Bare Drum Pull	Allowable Cable Pull
With standard rotation resistant rope	10,200 lb (4627 kg)	7,700 lb (3493 kg)

Block Type	Rating	Weight
Downhaul Weight	3.85 ton (3.49 t)	150 lb (68 kg)
1 Sheave Block	11.55 ton (10.48 t)	200 lb (91 kg)
2 Sheave Block	19.25 ton (17.46 t)	355 lb (161 kg)

600E

capacities

5

Load Rating Chart: Series 690E with 45 ft. Jib

Other series 600E Load Rating Charts are available. National will send you a chart on request – or you may secure needed load rating information through your nearest National dealer.

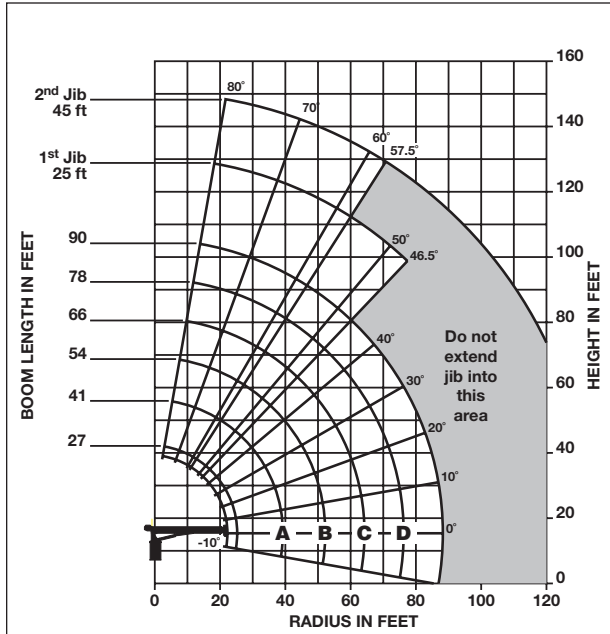

CAUTION:

- Do not operate crane booms, jib extensions, any accessories or loads within 10 ft (3m) of live power lines or other conductors of electricity.
- Jib and boom capacities shown are maximum for each section.
- Do not exceed capacities at reduced radii
- Load ratings shown on the load rating charts are maximum allowable loads with the outriggers properly extended on a firm, level surface and the crane leveled and mounted on a factory recommended truck.
- Always level the crane with the level indicator located on the crane.
- The operator must reduce load to allow for factors such as wind, ground conditions, operating speeds and their effects on freely suspended loads.
- Overloading this crane may cause structural collapse or instability.
- Weights on any accessories attached to the boom or loadline must be deducted from the load chart capacities.
- Do not exceed jib capabilities at any reduced boom lengths.
- Do not deadhead lineblock against boom tip when extending boom or winching up.
- Keep at least three wraps of loadline on drum at all times.
- Use only specified cable with this machine.

**SERIES 690E
WITH
45 FT JIB**

NOTE:

1. Operate with jib by radius when main boom is fully extended. If necessary increase boom angle to maintain loaded radius.
2. Operate with jib by boom angle when main boom is not fully extended. Do not exceed rated jib capacities at any reduced boom lengths.

LOADLINE EQUIPMENT DEDUCT (lb)

Downhaul weight	150
One sheave block	200
Two sheave block	355

Load Rating: Series 690E with 45 ft. Jib

LOADED RADIUS (FT)	LOADED BOOM ANGLE (DEG)	27 FT BOOM (LB)	LOADED BOOM ANGLE (DEG)	A 41 FT BOOM (LB)	LOADED BOOM ANGLE (DEG)	B 54 FT BOOM (LB)	LOADED BOOM ANGLE (DEG)	C 66 FT BOOM (LB)	LOADED BOOM ANGLE (DEG)	D 78 FT BOOM (LB)	LOADED BOOM ANGLE (DEG)	90 FT BOOM (LB)	LOADED BOOM ANGLE (DEG)	25 FT JIB (LB)	LOADED BOOM ANGLE (DEG)	45 FT JIB (LB)
5	77	40,000														
8	70	25,200														
10	66	20,800	74	20,550												
12	61.5	17,850	71	17,350	76	16,700										
14	57	15,800	68	14,850	74	14,700	77.5	14,250								
16	51	14,150	65.5	12,900	71.5	12,900	75.5	12,350								
20	40	10,650	58.5	10,400	67.5	10,200	72	9,700	76	9,500	77.5	7,700				
25	19	6,900	50	8,650	61.5	7,850	67	7,650	71.5	7,550	74.5	7,400	78	2,800		
30			40	7,150	55	6,450	62.5	6,200	68	6,050	71.5	6,000	75.5	2,500	78	1,700
35			26.5	4,850	48	5,400	58	5,200	63.5	5,000	68	4,850	73	2,200	76	1,500
40					40	4,300	52	4,300	59.5	4,200	64.5	4,000	70	1,900	74	1,300
45					32	3,550	46.5	3,600	54.5	3,500	61	3,350	67.5	1,600	71.5	1,100
50					16.5	2,150	39.5	2,900	50	2,950	57	2,800	64.5	1,400	69.5	1,000
55							31	2,300	44.5	2,450	53.0	2,350	62	1,200	67	900
60							21.5	1,550	39.5	2,050	48.5	1,950	59	1,000	65	800
65									32.5	1,550	44	1,650	56	800	62.5	700
70									24	1,050	39	1,300	53	700	60	600
75											33	950	50	600	57.5	500
80											26.5	600	46.5	500		
85																
	0	3,550	0	1,550	0	550										

THIS CHART IS ONLY A GUIDE AND SHOULD NOT BE USED TO OPERATE THE CRANE. The individual crane's load chart, operating instructions and other instructional plates must be read and understood prior to operating the crane.

capacities

Load Rating Chart: Series 690E with No Jib

6

Other series 600E Load Rating Charts are available. National will send you a chart on request – or you may secure needed load rating information through your nearest National dealer.

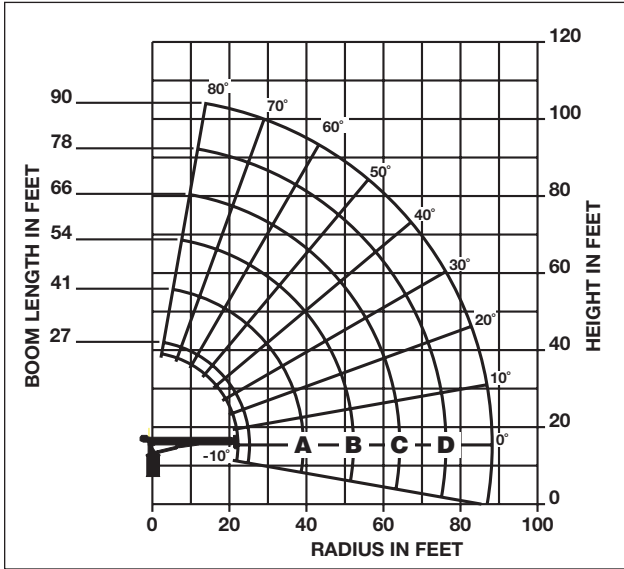

CAUTION:

- Do not operate crane booms, jib extensions, any accessories or loads within 10 ft (3m) of live power lines or other conductors of electricity.
- Jib and boom capacities shown are maximum for each section.
- Do not exceed capacities at reduced radii
- Load ratings shown on the load rating charts are maximum allowable loads with the outriggers properly extended on a firm, level surface and the crane leveled and mounted on a factory recommended truck.
- Always level the crane with the level indicator located on the crane.
- The operator must reduce load to allow for factors such as wind, ground conditions, operating speeds and their effects on freely suspended loads.
- Overloading this crane may cause structural collapse or instability.
- Weights on any accessories attached to the boom or loadline must be deducted from the load chart capacities.
- Do not exceed jib capabilities at any reduced boom lengths.
- Do not deadhead lineblock against boom tip when extending boom or winching up.
- Keep at least three wraps of loadline on drum at all times.
- Use only specified cable with this machine.

**SERIES 690E
WITH
NO JIB**

LOADLINE EQUIPMENT DEDUCT (lb)

Downhaul weight	150
One sheave block	200
Two sheave block	355

Load Rating Chart: Series 690E with No Jib

LOADED RADIUS (FT)	LOADED BOOM ANGLE (DEG)	27 FT BOOM (LB)	LOADED BOOM ANGLE (DEG)	A 41 FT BOOM (LB)	LOADED BOOM ANGLE (DEG)	B 54 FT BOOM (LB)	LOADED BOOM ANGLE (DEG)	C 66 FT BOOM (LB)	LOADED BOOM ANGLE (DEG)	D 78 FT BOOM (LB)	LOADED BOOM ANGLE (DEG)	90 FT BOOM (LB)
5	77	40,000										
8	70	25,750										
10	66	21,400	74	20,950								
12	61.5	18,450	71	17,750	76	17,000						
14	57	16,400	68	15,250	74	15,000	77.5	14,450				
16	51	14,750	65.5	13,300	71.5	13,200	75.5	12,600				
20	40	11,250	58.5	10,800	67.5	10,500	72	9,950	76	9,700	77.5	7,850
25	19	7,500	50	9,050	61.5	8,150	67	7,900	71.5	7,750	74.5	7,550
30			40	7,550	55	6,750	62.5	6,450	68	6,250	71.5	6,150
35			26.5	5,250	48	5,700	58	5,450	63.5	5,200	68	5,050
40					40	4,600	52	4,550	59.5	4,400	64.5	4,200
45					32	3,850	46.5	3,850	54.5	3,700	61	3,550
50					16.5	2,450	39.5	3,150	50	3,150	57	3,000
55							31	2,550	44.5	2,650	53.0	2,550
60							21.5	1,800	39.5	2,250	48.5	2,150
65									32.5	1,750	44	1,850
70									24	1,250	39	1,500
75									11	450	33	1,150
80											26.5	800
85												
	0	4,150	0	1,950	0	850						

600E

THIS CHART IS ONLY A GUIDE AND SHOULD NOT BE USED TO OPERATE THE CRANE. The individual crane's load chart, operating instructions and other instructional plates must be read and understood prior to operating the crane.

Radio Remote Controls –

Eliminate the handling and maintenance concerns that accompany cabled remotes. Operate to a range of about 250 feet (76 m), varying with conditions.

- **Model R4R**

One-Person Basket –

Strong but lightweight steel basket with 300-lb (139-kg) capacity, gravity hung with swing lock and full body harness.

- **Model B1-S**
- **Model 2B1-S** (for dual locking baskets)

Heavy-duty Personnel Basket –

1,200-lb. (544-kg) capacity steel basket with safety loops for four passengers. Gravity leveling 72- x 42-inch (183- x 107-cm) platform. Fast attachment and secure locking systems. Load chart must show 2,300 lb. (1043 kg) minimum to operate this accessory.

- **Model BSA-1**
- **Model BSA-R1** (provides rotation)

Hydraulic Oil Cooler –

Automatic, self-contained radiator system with electric fans cools oil under continuous operation.

- **Model OC**

Continuous Rotation –

Allows rotation of turret/boom without rotation stop.

- **Model CR**

Dimensions Specifications

WEIGHT INCLUDES ALL ITEMS EXCEPT ASH (830lb / 363kg) AND BED

SERIES	RETRACTED LENGTH	EXTENDED LENGTH	G (wet) Inches (m)	DRYWT lb (kg)	WITH OILWT lb (kg)
690E	27'10"	90'	83 (2.11)	16,705 (7,576)	17300**
690E	27'10"	90'	87.5 (2.22)	16,090 (6,206)	18685***

*INCLUDES STANDARD 18' SUBBASE
 **INCLUDES STANDARD 20' SUBBASE
 ***INCLUDES 20' INTEGRAL BED/BOX

SUBBASE	WEIGHT lb (kg)	C.G. LENGTH (m)
STANDARD 18'	2710 (1229)	113 (2.87)
STANDARD 20'	2945 (1336)	116 (2.95)
20' INTEGRAL BED/BOX	4330 (1964)	124 (3.15)

SUBBASE C.G. ARE LOCATED FROM CENTER OF ROTATION

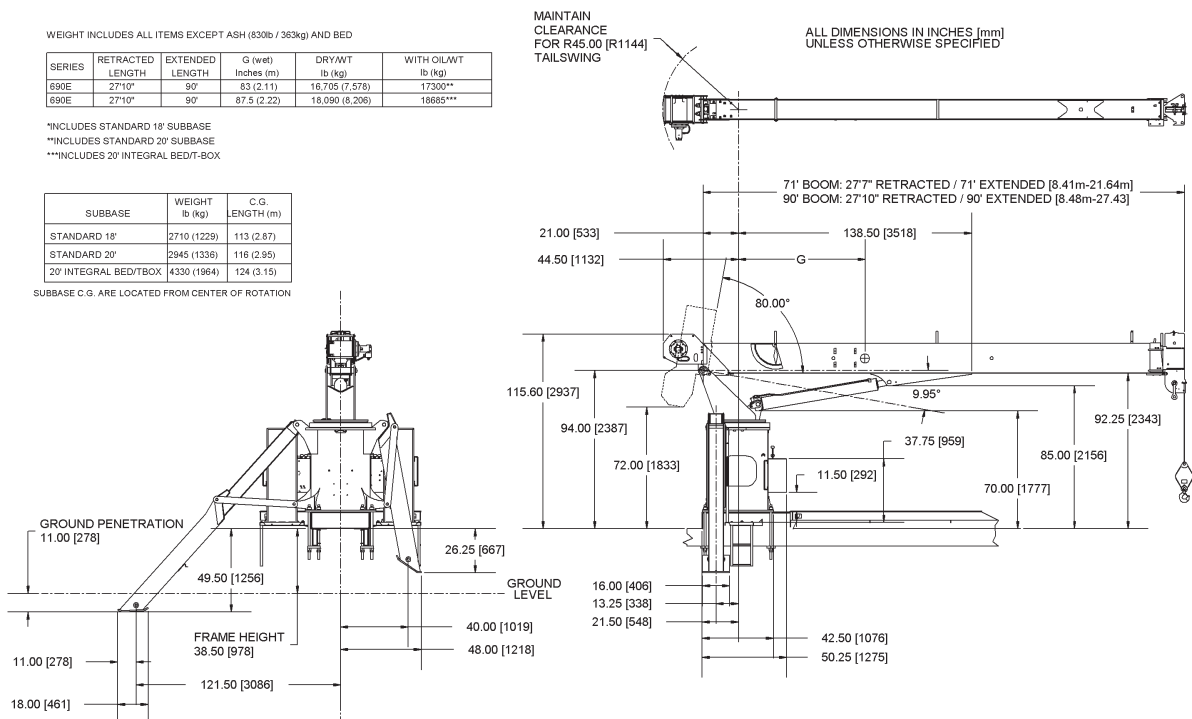



Manitowoc Crane Group - Americas
 Manitowoc, Wisconsin Facility
 Tel: [Int + 001] 920 684 6621
 Fax: [Int + 001] 920 683 6277
 Shady Grove, Pennsylvania Facility
 Tel: [Int + 001] 717 597 8121
 Fax: [Int + 001] 717 597 4062

Manitowoc Crane Group - EMEA
 Europe Middle East & Africa
 Tel: [Int + 33] (0) 191 565 6281
 Fax: [Int + 33] (0) 4 72 18 20 20

Manitowoc Crane Group - UK
 Europe Middle East & Africa
 Tel: [Int + 44] (0) 191 565 6281
 Fax: [Int + 44] (0) 191 564 0442

Manitowoc Crane Group - Germany
 (Sales, Parts & Service)
 Tel: [Int + 49] (0) 2173 8909 0
 Fax: [Int + 49] (0) 2173 8909-30

Manitowoc Crane Group - France
 France & Africa (Sales, Parts & Service)
 Tel: [Int + 33] (0) 1 303 13150
 Fax: [Int + 33] (0) 1 303 86085

Manitowoc Crane Group - Netherlands
 (Sales, Parts & Service)
 Tel: [Int + 31] (0) 76 578 39 99
 Fax: [Int + 31] (0) 76 578 39 78

Manitowoc Crane Group - Italy
 Italy & Southern Europe (Sales, Parts & Service)
 Tel: [Int + 39] (0) 331 49 33 11
 Fax: [Int + 39] (0) 331 49 33 30

Manitowoc Crane Group - Portugal
 Portugal & Spain (Sales, Parts & Service)
 Tel: [Int + 351] (0) 22 968 08 89
 Fax: [Int + 351] (0) 22 968 08 97

Manitowoc Crane Group - Singapore
 Asia/Pacific excl China (Sales, Parts & Service)
 Tel: [Int + 65] 6861 1733
 Fax: [Int + 65] 6862 4040 / 4142

Manitowoc Crane Group - Shanghai
 China (Sales, Parts & Service)
 Tel: [Int + 86] (0) 21 64955555
 Fax: [Int + 86] (0) 2164852038

Manitowoc Crane Group - Beijing
 China (Sales, Parts & Service)
 Tel: [Int + 86] (0) 10 646 71690
 Fax: [Int + 86] (0) 10 646 71691

Manitowoc Crane Group - Middle East
 Sales
 Tel: [Int + 971] (0) 4 348 4478
 Fax: [Int + 971] (0) 4 348 4478
 (Parts & Service)
 Tel: [Int + 973] (0) 9 660 899
 Fax: [Int + 973] (0) 2 707 740

Distributed By:



www.manitowoccrane.com



Constant improvement and engineering progress make it necessary that we reserve the right to make specification, equipment, and price changes without notice. Illustrations shown may include optional equipment and accessories, and may not include all standard equipment.