

# AC 4100XPC

Electric Mining Shovel  
Digital AC Drive Control

## Operating Specification

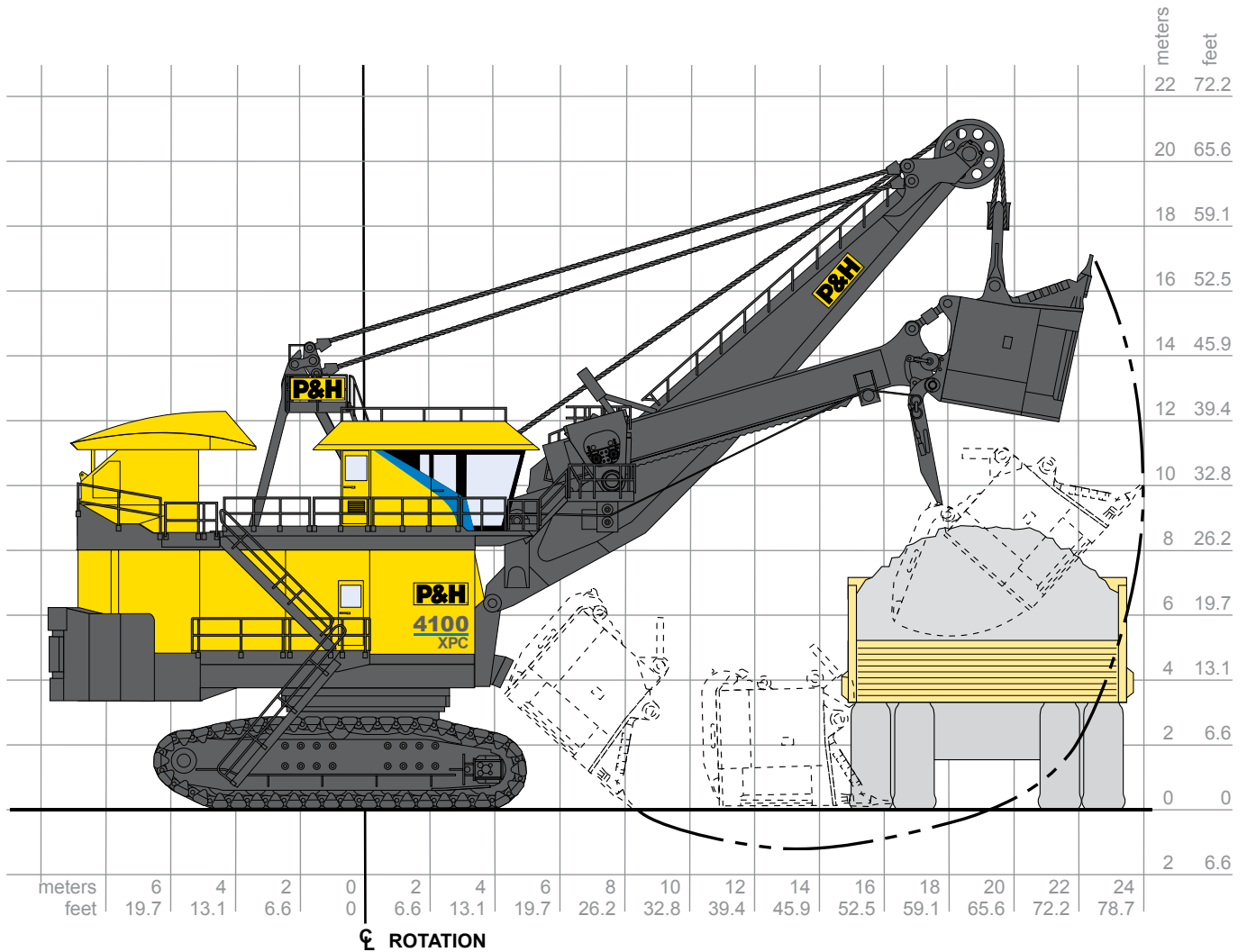

⊕ ROTATION

Working Ranges		
Height of Cut	16.8 m	55 ft. 2 in.
Radius of Cut	23.9 m	78 ft. 8 in.
Dumping Height* (Door Open)	9.5 m	31 ft. 0 in.
Floor Level Radius	16.0 m	52 ft. 6 in.
Tail Swing Radius	9.8 m	32 ft. 3 in.
Operator Eye Level	10.1 m	33 ft. 1 in.

\* Height shown with bail-type dipper. Heights will be greater with bail-less or compact-bail dippers. Actual dumping height can be greater than door clearance height.

Capacity		
Nominal Pay Load	99.8-108.9 mt	110-120 st
Nominal Dipper Capacity		
SAE struck	53.5-62.7 m <sup>3</sup>	70-82 yd <sup>3**</sup>
SAE 2:1	67.6 m <sup>3</sup>	88.4 yd <sup>3</sup>
Rated Suspended Load	195 mt	215 st
Optimum Truck Size (400 st truck shown)	172-363 mt	190-400 st

\*\*Capacity and payload dependent on the application.



## Electrical Control

- P&H Centurion™ Supervisory Controller provides direct integrated communication with motor drives giving precise motor control and fast cycle times. Real-time multi-tasking capability allows for optimal machine logic sequencing, monitoring and control.
- Centurion I/O System uses 'Profibus' communication protocol for seamless integration of all shovel subsystems and future expandability. Low-voltage 24V DC I/O drop points feature open and short circuit detection for improved diagnostics and troubleshooting.
- Centurion Information System's enhanced Graphical User Interface (GUI) features intuitive, icon-based screens to display vital information such as shovel status, troubleshooting information, and optional production monitoring data and operator feedback.



## Electrical Control Systems

### ELECTRICAL DRIVE RATINGS

(50°C, 2000m) Drive Power

IGBT Supply Unit (ISU)	4550 kVA
Crowd Motion	1160 kVA
Hoist Motion	4640 kVA
Propel Motion	2320 kVA
Swing Motion	2320 kVA

The electrical drive system is comprised of a multi drive platform, sharing a common DC bus between the IGBT Supply Unit (ISU) and the motor drive Inverter Units (INU). The fully regenerative ISU controls the power flow to and from the shovel, maintaining a unity power factor with extremely low harmonic content. The fully regenerative INU controls the power flow to and from the individual AC motors.

### P&H AC FAST RESPONSE MAIN MACHINERY MOTORS

Hoist Motor (Two used)	Continuous rating @ 690 volts Peak developed power	Total 2388kW/3200hp 2976kW/3990hp
Swing Motor (Three used)	Continuous rating @ 690 volts Peak developed power	Total 1090kW/1460hp 1380kW/1850hp
Crowd Motor (One used)	Continuous rating @ 690 volts Peak developed power	Total 545kW/730hp 774kW/1037hp
Propel Motor (Two used)	Continuous rating @ 690 volts Peak developed power	Total 1090kW/1460hp 1678kW/2250hp



## Power Requirements

Supply Voltage\* 7200 or 13800V 6000, 6600, 7200 or 11000  
3 Phase, 60 Hz 3 Phase, 50 Hz.

Supply Transformer (Minimum) 3750 kVA

Minimum Short Circuit VA Available at Shovel 30 MVA

\*Voltage per customer requirements

### TRANSFORMER

Main Transformer	4000 kVA
Auxiliaries Transformer	400 kVA
Control/Lighting Supply Winding	50 kVA

Note: Transformer capacities may vary depending on options.



## Dipper & Dipper Trip

- P&H® OPTIMA® dippers combine consistent productivity with high durability and maintainability. Dippers are configured to mine specific conditions and capacity requirements from a variety of combinations of body and lip designs, as well as other unique P&H technologies. Specific wear packages and GET styles can be cooperatively specified.
- P&H TripRite™ system utilizes a brushless DC electric motor with sealed planetary drive unit for reliable trip and slack take up operation.



## Hoist

- All gearing housed in single enclosed gear case with filtered and cooled oil fed to all bearings in addition to splash lubrication for reliable operation and ease of maintenance.
- Large 68" diameter hoist drum for extended rope bending life. Ferrule becket system and dual electric tuggers are standard for efficient rope change.
- Spring set air release disc brakes - one per motor.



## Crowd

- Powerband V-belt drive between motor and gear case absorbs shock loads.
- First and second reduction gearing in enclosed gear case for reliable splash lubrication, ease of maintenance, and extended component life.
- Twin leg dipper handle with torsion box and rack and pinion drive has inherent stability in the bank for optimal digging.
- Spring set air release disc brake.



## Swing

- Three modular P&H planetary gear cases of proven design and a single piece forged swing gear transmit torque for fast cycle times.
- Spring set air release disc brakes - one per motor.
- Splash lube optional filtration system.



## Propel

- Propel on demand provides rapid transfer to propel mode. Rapid transfers allow frequent positioning of the shovel to the bank resulting in faster cycle times and more efficient digging.
- Two rugged P&H planetary gear cases of proven design independently transmit torque to the drive sprockets, producing the tractive effort required for fast, efficient propel and positioning operations.
- P&H DELTA™ Drive low tension sprocket drive system with heavy duty cast crawler shoes.
- Spring set air release disc brakes - one per motor.



## Cable Data

Hoist (wire rope)	73 mm	2.87 in. dia.
Suspension (bridge strand)	102 mm	4.00 in. dia.
Dipper Trip (wire rope)	19 mm	0.75 in. dia.

## Overall Dimensions

A	Width	14.4 m	47 ft. 1 in.
B	Length	15.0 m	49 ft. 4 in.
C	Height Over Gantry	14.7 m	48 ft. 3 in.
D	Width of Crawler Shoes	1930 mm (std.) 2210 mm	76 in. (std.) 87 in.
E	Width of Crawlers (std.)	10.5 m	34 ft. 5 in.
F	Length of Crawlers	11.7 m	38 ft. 6 in.
G	Ground Clearance	0.7 m	2 ft. 2 in.
H	Height — Ground to Bottom of Counterweight Slabs	3.6 m	11 ft. 10 in.
I	Height — Ground to Bottom of Counterweight	3.6 m	11 ft. 10 in.

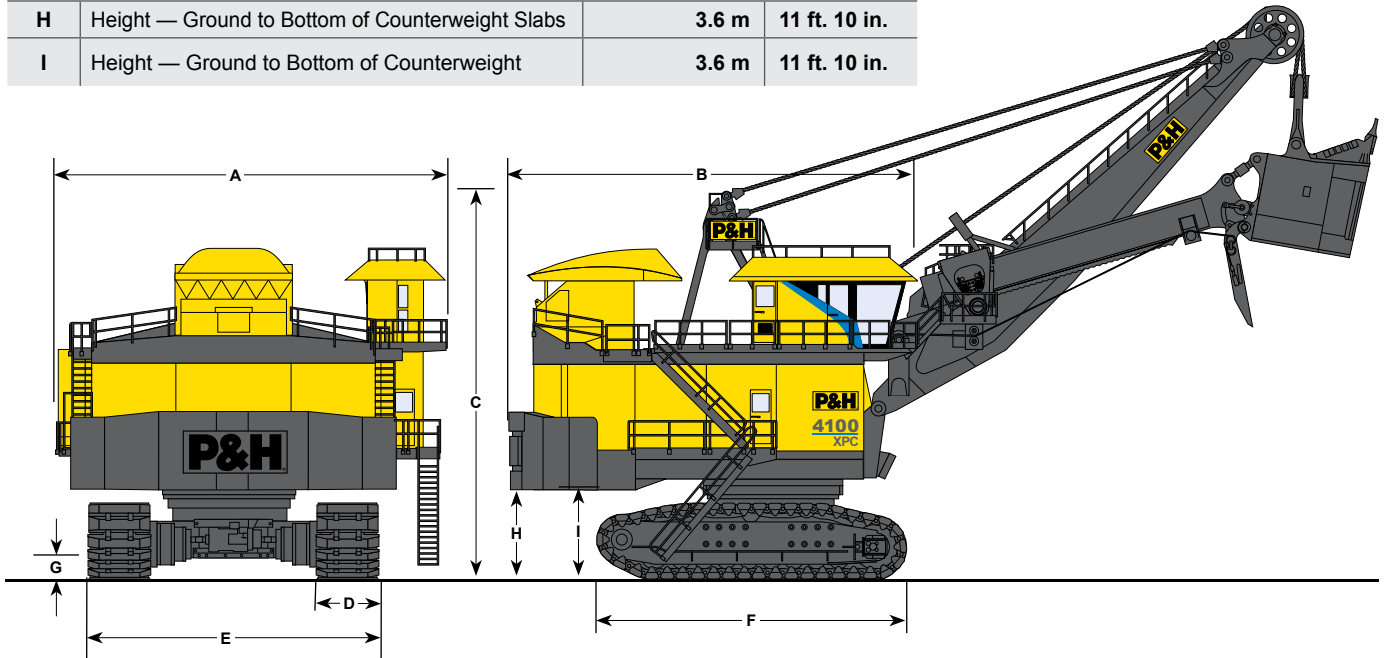

## Machinery Deck Plan

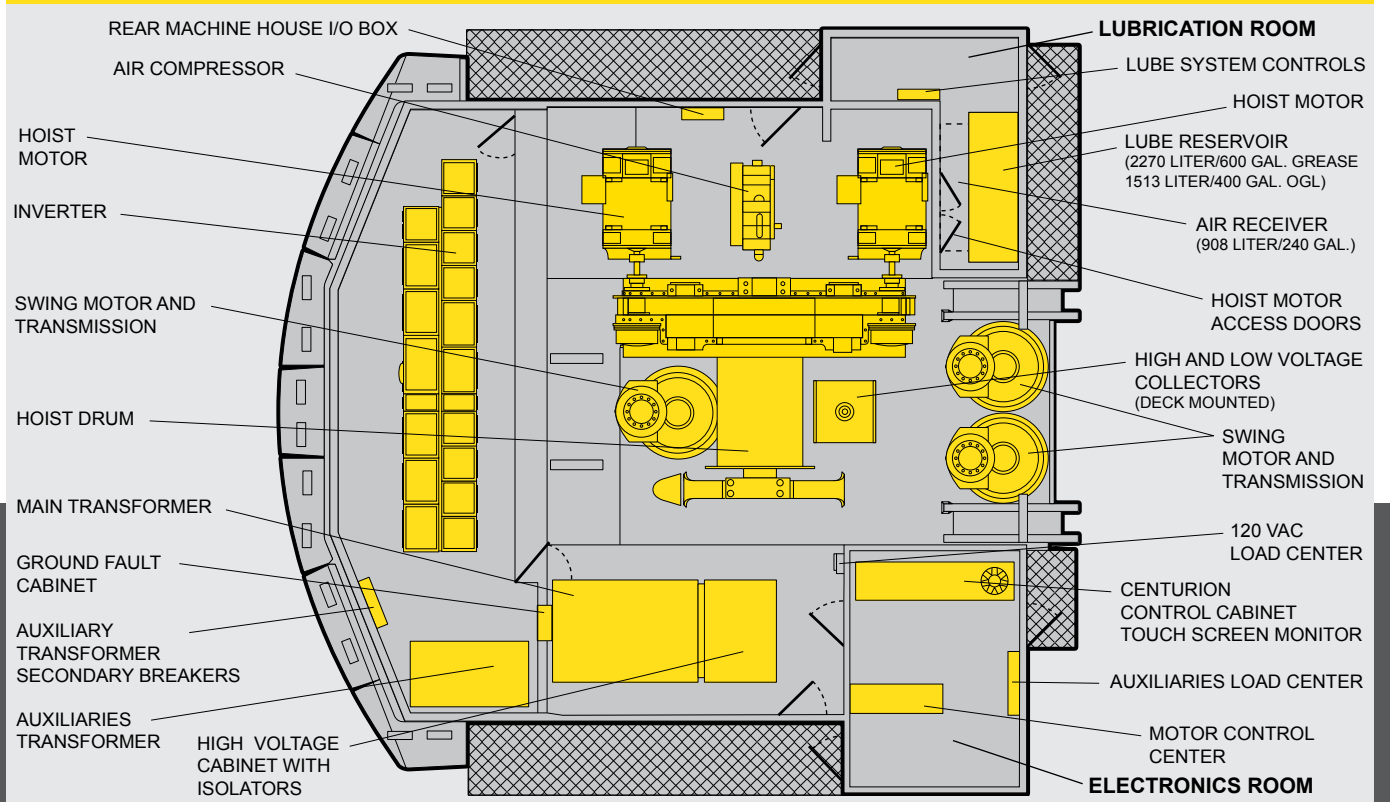



## Ground Pressure & Weight

### BEARING AREA - GROUND PRESSURE

Standard:

Crawler Bearing Area 76" Shoes/ 1930mm	34.58 m <sup>2</sup>	53,597 in <sup>2</sup>
Crawler Ground Pressure 76" Shoes/ 1930mm	434.4 kPa	63.0 psi

Optional:

Crawler Bearing Area 87" Shoes/ 2210mm	39.58 m <sup>2</sup>	61,354 in <sup>2</sup>
Crawler Ground Pressure 87" Shoes/ 2210mm	379.9 kPa	55.1 psi

### WEIGHTS - APPROXIMATE\*

Working Weight (with Dipper, Approx. Wt.)

76" Shoes/1930mm	1,532,235 kg	3,378,000 lbs
87" Shoes/2210mm	1,536,771 kg	3,388,000 lbs
Counterweight (Punchings)**	204,100 kg	450,000 lbs

\* All weights subject to 5% variation.

\*\* To be furnished by customer.



## Features And Customization

The 4100XPC is built with several features to enhance safety, reliability, and productivity over the life cycle of the operation.

- Automatic Lubrication and Compressed Air Systems with advanced diagnostic and control
- Temperature Monitoring System for all motors, drum shaft bearings, shipper shaft bearings
- Automatic Boom Soft Setdown System (ABSS) and Boom Profile Protection Envelope to help prevent excessive loading to the attachment during operation
- Anti-Swing-in-Bank system to reduce excessive side loading on handle and attachment
- Remote hoist control pendant and hoist rope winch to assist in safe and efficient rope changeouts
- House Pressurization System to provide filtered air for cooling and dust repression

The standard shovel can be customized for local and minesite specific conditions in the following areas:

- Operator Cab
- Climate Control
- Cold Weather Equipment
- Technology and Software
- Electrical and Mechanical Systems
- Maintenance Systems



## Lighting

**Standard:** Metal Halide, 400 W, high intensity discharge (HID) primary exterior floodlights (11) mounted on the operator's cab, RH room, LH room and machinery house. Secondary exterior floodlight combination of Halogen, 500 W (3) and fluorescent lights (6) mounted under revolving frame. Incandescent lights (5) outside cab and house doors and (1) inside operator's cab. Fluorescent lights (23) illuminate interior of the machinery house, RH and LH room.

**Optional:** High Pressure Sodium, 400 W or 1000 W primary exterior floodlights.



## Loading Control Center

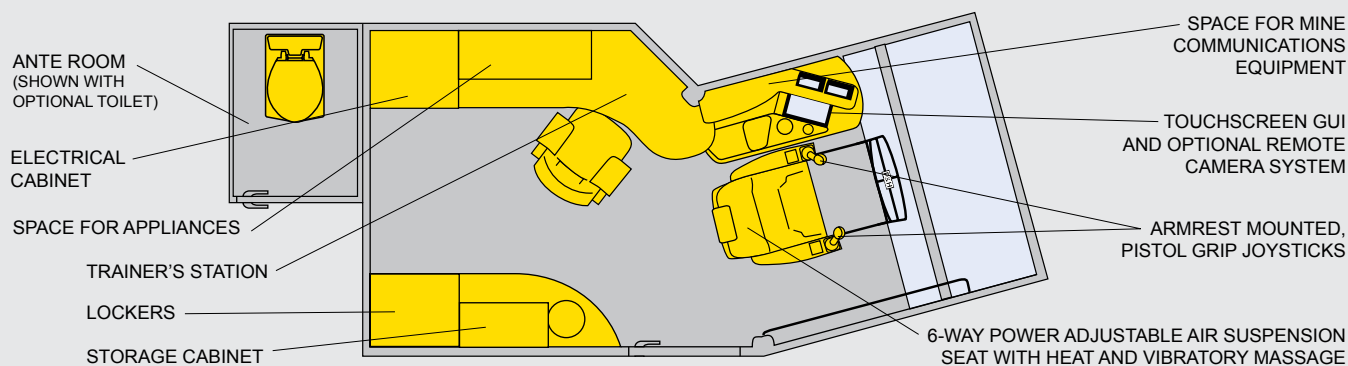

P&H MinePro Services  
 1-888-MINEPRO  
 Outside the U.S. and Canada  
 Phone: (414) 671-4400  
 Fax: (414) 670-7306  
[www.minepro.com](http://www.minepro.com)  
[www.phmining.com](http://www.phmining.com)

NOTE: All designs, specifications and components of the equipment described above are subject to change at manufacturer's sole discretion at any time without advance notice. Data published herein is informational in nature and shall not be construed to warranty the suitability of the equipment for any particular purpose as performance may vary with conditions encountered. The only warranty applicable is our standard written warranty for this equipment.

P&H, P&H MinePro Services, P&H Centurion, Optima, Delta and TripRite are trademarks of Joy Global Inc. or one of its affiliates.  
 © 2011 P&H Mining Equipment Inc. All rights reserved.