

CLASSIC

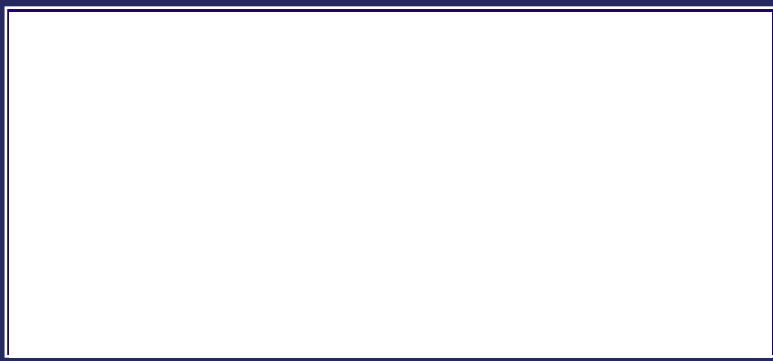

EN12999

CONFORME ALLE NORME DI SICUREZZA EU
IN ACCORDANCE TO THE EU SAFETY STANDARDS
CONFORME AUX NORMES DE SECURITE EU
GEMÄß EU SICHERHEITSRICHTLINIEN
CONFORME CON LAS NORMAS DE SEGURIDAD EU

H1B3

CLASSE DI SOLLECITAZIONE A FATICA H1B3
FATIGUE-TESTED IN CLASS H1B3
ESSAIS EN FATIGUE EN CLASSE H1B3
ERMÜDUNGSTEST NACH KLASSE H1B3
COMPROBACIÓN DEFATIGA EN LA CLASE H1B3

[3]

3 ANNI DI GARANZIA SULLE PARTI STRUTTURALI
3 YEARS OF WARRANTY ON THE STRUCTURAL PARTS
3 ANS DE GARANTIE SUR LES PARTIES STRUCTURELLES
3 JAHRE GARANTIE AUF STRUKTURBAUTEILE
3 AÑOS DE GARANTÍA EN LAS PARTES ESTRUCTURALES

[IIA]

DICHIARAZIONE DI CONFORMITÀ DEL PRODUTTORE
DECLARATION OF CONFORMITY OF THE MANUFACTURER
DECLARATION DE CONFORMITE DU PRODUCTEUR
KONFORMITÄTSEKTLÄRUNG DES HERSTELLERS
DECLARACIÓN DE CONFORMIDAD DEL PRODUCTOR

PQS

SISTEMA DI VERNICIATURA DI QUALITÀ CERTIFICATA
CERTIFIED PAINTING QUALITY SYSTEM
SYSTÈME DE PEINTURE DE QUALITÉ CERTIFIÉ
ZERTIFIZIERTES QUALITÄTS-LACKIERSYSTEM
SISTEMA DE BARNIZADO DE CALIDAD CERTIFICADA

Tutte le gru PM sono coperte da polizza assicurativa internazionale per la responsabilità verso terzi.
All PM Cranes are covered by international insurance policy for civil liability third party.
Toutes les grues sont couvertes par une police d'assurance internationale de responsabilité civile envers tiers.
PM Krane sind durch eine internationale Haftpflichtversicherung gegen Dritte abgesichert.
Todas las grúas PM cuentan con una póliza de seguros internacional contra las responsabilidades civiles hacia terceros.

EQUIPAGGIAMENTO DI SERIE - CONFIGURATION STANDARD EQUIPMENT - CONFIGURATION EQUIPEMENT STANDARD - SERIENMÄSSIG - EQUIPO DE SERIE



Cremagliera
Slewing by rack
Rotation avec crémaillère
Zahnstangenschwenkwerk
Rotación con cremallera



Bracci stabilizzatori a sfilo manuale
Manual pull-out outrigger booms
Bras stabilisateurs avec extension manuelle
Manuelle Abstützungen
Brazos estabilizadores a salida manual



Uscita sequenziale sfilo bracci
Sequential extension booms' output
Sortie bras séquentiel
Anzahl der Ausschubzylinder
Salida secuencial de los brazos



Dispositivo automatico sicurezze stabilizzatori inserite
Safety Kit for outriggers
Dispositif de sécurité stabilisateurs
Sicherheitskit für die Abstützungen
Kit de Seguridad para estabilizadores

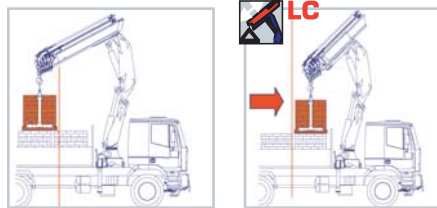

- Gru PM, versione LC, con primo braccio retraibile idraulicamente, agevola le movimentazioni ingombranti e gravose a corto raggio, ottimizzando anche le posizioni di carico sotto colonna.
- PM crane in LC version, with first hydraulic retractable boom, optimizes the load positioning close to the column, and makes easy the placement of heavy and bulky loads.
- La version LC, le premier bras rétractable hydrauliquement, facilite le chargement du matériel lourd et encombrant en augmentant la hauteur disponible sous crochet et la capacité de soulèvement près de la colonne.
- Die LC Ausführung, d.h. der hydraulisch einfahrbare erste Ausleger ermöglicht es sperrige Güter und große Lasten nah an der Säule zu heben. Dies wird auch durch die hohe Hakenfreiheit ermöglicht.
- En la versión LC, el primer brazo se recoge hidráulicamente, así que permite de elevar, mover y también colocar material pesado y de gran tamaño cerca de la columna.

OPTIONAL



Configurazione LC
LC configuration
Configuration LC
LC Ausführung
Configuración LC



Scambiatore di calore
Oil cooler
Réfrigérisseur
Ölkühler
Enfriador de aceite



Antenna
Fly-Jib
Jib
Jib
Jib



Terzo punto di manovra
Stand up control
Poste debout
Hochstand
Mando en pié



Posto in alto
Top seat
Siège à la colonne
Hochsitzsteuerung
Mando en altura



Verricello idraulico su gru
Hydraulic winch on crane
Treur hydraulique sur la grue
Hydraulische Winde am Kran
Cabrestante hidráulico sobre la grúa



Canaline raccogli tubo
Activations with racks
Activations avec gouttières
Schlauchketten für Zusatzgeräte
Bandejas



Bracci stabilizzatori a sfilo idraulico
Hydraulic pull-out outrigger booms
Bras stabilisateur à extension hydraulique
Hydraulische Abstützungen
Brazos estabilizadores a salida hidráulica



Blocco Rotazione Elettroidraulico
Slewing limiter locking device electronic/hydraulic
Soupape d'arrêt rotation électronique/hydraulique
Elektronische Schwenkbereichsbegrenzung
Bloqueo rotación electrónico/hidráulico



Serbatoio
Oil tank
Réservoir
Öltank
Depósito de Aceite



Prolunghe manuali
Manual extensions
Rallonges manuelles
Mechanische Verlängerungen
Prolongas manuales



LMU: sistema di controllo CE per prolunghe meccaniche
LMU Device: control system for manual extensions
Dispo LMU: système de contrôle CE pour rallonges manuelles
LMU: CE Kontrollsystem für mechanische Verlängerungen
LMU: Sistema de control CE por prolongas manuales

- Martinetti stabilizzatori rotanti manuali
- Manual tilting outriggers
 - Vérins pivotant manuellement
 - Manuell schwenkbare Abstützungen
 - Brazos estabilizadores giratorios manuales

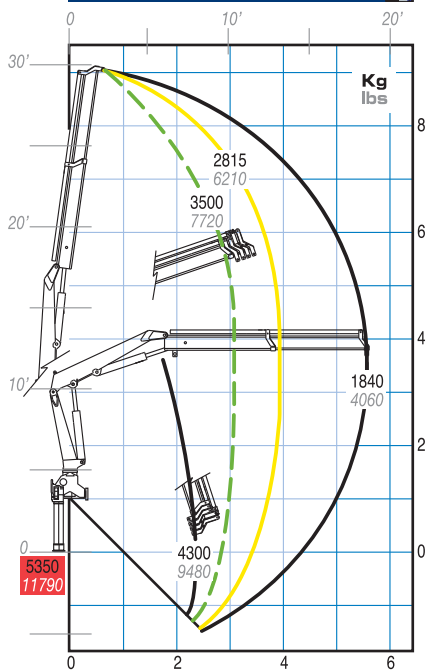
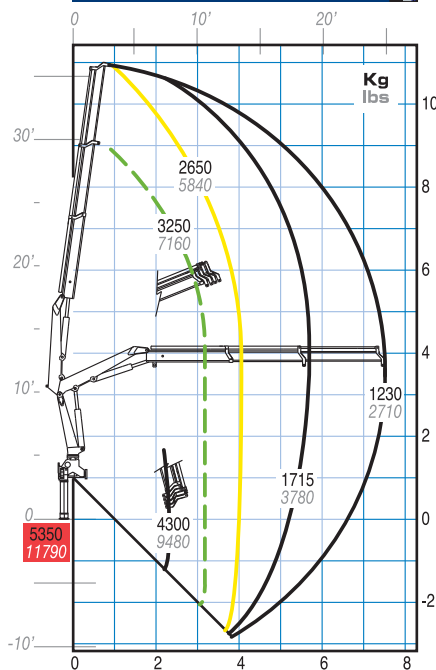
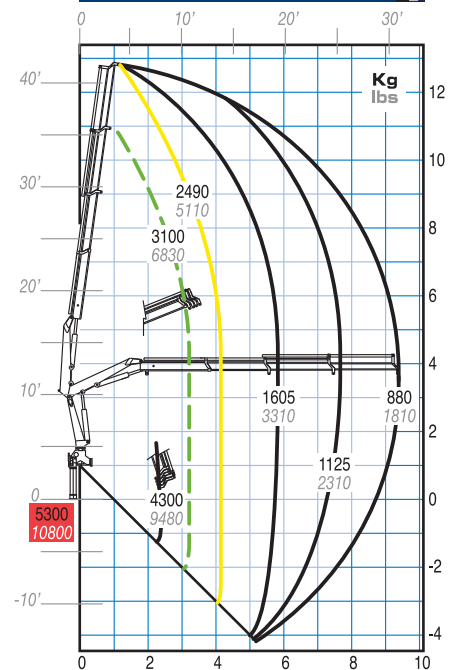
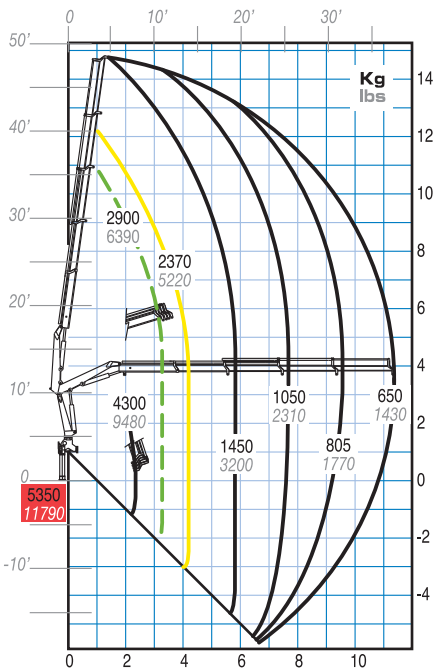
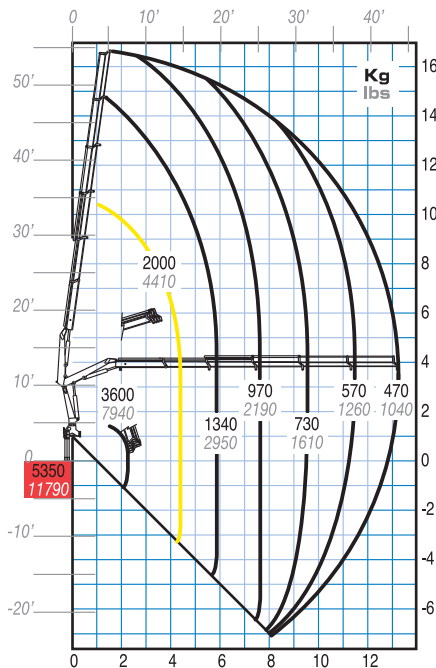

- Disponibile fino a 5 sfili idraulici
- Available up to 5 hydraulic extensions
- Disponible jusqu'à 5 extensions hydraulique
- Bis zu 5 hydraulische Ausschübe erhältlich
- Disponible hasta 5 extensiones hidráulicas

11021 - 11021 LC**11022 - 11022 LC****11023 - 11023 LC****11024 - 11024 LC****11025**

— Portata massima passante per l'orizzontale - Max. capacity from horizontal to vertical - Capacité maxi passant par l'horizontale - Max. Tragkraft von horizontal bis zu vertical - Máxima capacidad de la horizontal a la vertical

■ Portata massima nominale al gancio fisso - Max. nominal capacity with fixed hook - Capacité maxi nominale au crochet fixe - Max. Nenntragkraft an der inneren Hakenbefestigung - Capacidad máxima en el gancho fijo

- - Solo con gru in versione LC - Only with LC version - Seulement avec version LC - Nur LC Version - Solo con grúa en versión LC

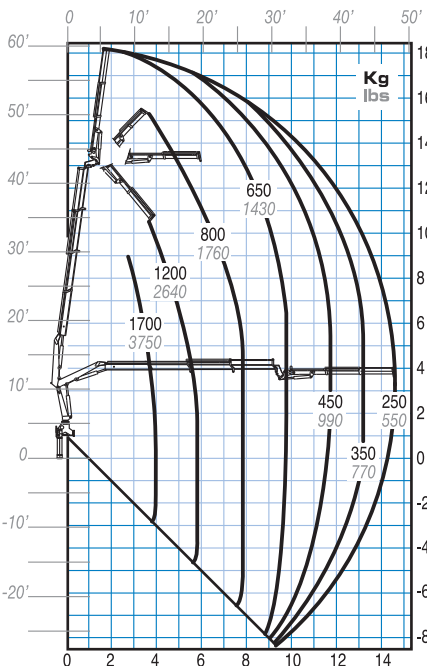
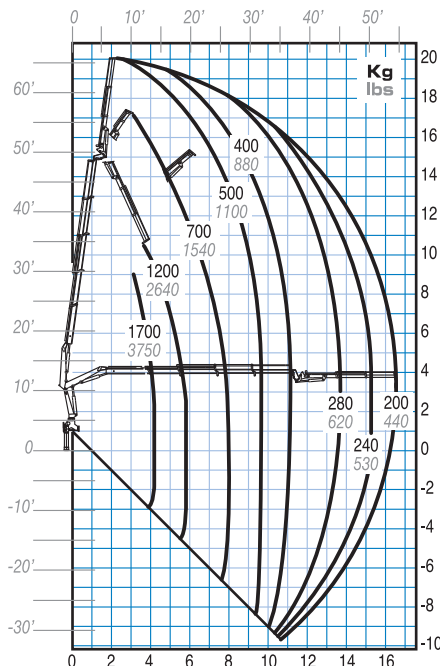
11023 + J12**11024 + J12**

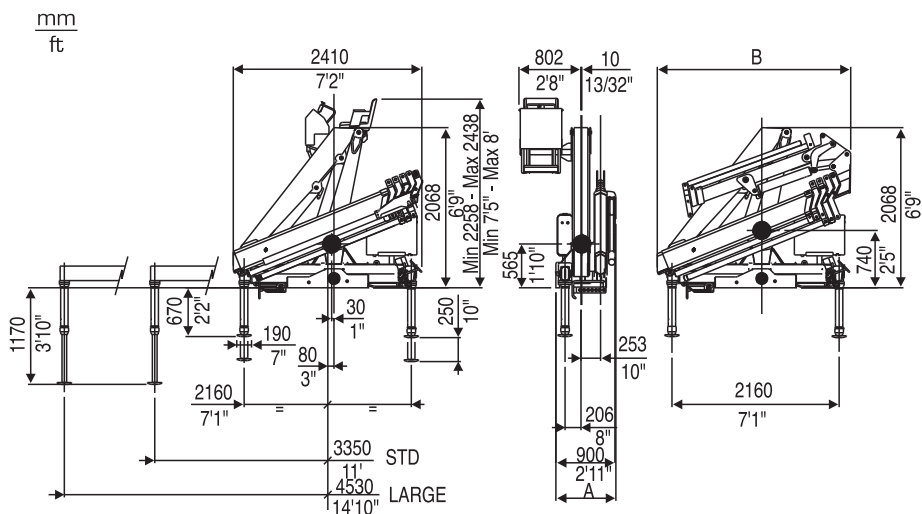

Abbinamento gru/veicolo Trucking crane combination Accouplement grue/véhicule Kran zusammen mit LKW Combinación grúa/camión

PTT/GVW	11		
12,0 ton			2 stabilizzatori STD 2 outriggers STD 2 stabilisateurs STD 2 Abstützungen STD 2 gatos de apoyo STD
13,5 ton			2 stabilizzatori STD 2 outriggers STD 2 stabilisateurs STD 2 Abstützungen STD 2 gatos de apoyo STD
15,0 ton			2 stabilizzatori XL 2 outriggers XL 2 stabilisateurs XL 2 Abstützungen XL 2 gatos de apoyo XL
18,0 ton			2 stabilizzatori XL 2 outriggers XL 2 stabilisateurs XL 2 Abstützungen XL 2 gatos de apoyo XL
19,0 ton			2 stabilizzatori XL 2 outriggers XL 2 stabilisateurs XL 2 Abstützungen XL 2 gatos de apoyo XL
26,0 ton			4 stabilizzatori 4 outriggers 4 stabilisateurs 4 Abstützungen 4 gatos de apoyo
32,0 ton			4 stabilizzatori 4 outriggers 4 stabilisateurs 4 Abstützungen 4 gatos de apoyo

	11021	11022	11023	11024	11025
A (mm)	780	780	780	780	920
A (ft)	2'7"	2'7"	2'7"	2'7"	3'

	11023+J12	11024+J12
B (mm)	2410	2500
B (ft)	7'11"	8'2"

PTT: Peso totale a terra - G.V.W. - P.T.A.C.
LKW Gesamtgewicht - Peso total del vehículo

		11021	11022	11023	11024	11025	11023 +J12	11024 +J12	
	Momento di sollevamento massimo - Maximum lifting moment - Moment de levage maxi - Max. Lastmoment - Momento de elevación máxima	tm	11,1	10,7	10,3	10,0	8,8	-	
		ft lbs	80430	77630	74750	72000	63850	-	
	Sbraccio oleodinamico - Maximum hydraulic reach - Allongement hydraulique Hydraulische Reichweite, Standard - Alcance hidráulico orizzontale - horizontal - horizontal - horizontal	m	5,80	7,70	9,60	11,60	13,50	14,90	
		ft	19'0"	25'3"	31'6"	38'1"	44'3"	48'11"	55'1"
	verticale - vertical - vertical - vertikal - vertical	m	9,10	11,00	12,90	14,80	16,40	18,00	20,10
		ft	29'10"	36'1"	42'4"	48'7"	53'10"	59'1"	65'11"
	Sbraccio con prolunghe - Maximum reach with manual extensions - Allongement avec rallonges manuelles - Reichweite, manuelle Verlängerungen - Alcance con prolongas manuales orizzontale - horizontal - horizontal - horizontal	m	-	-	15,30	15,30	15,30	16,30	
		ft	-	-	50'2"	50'2"	50'2"	53'6"	60'4"
	verticale - vertical - vertical - vertikal - vertical	m	-	-	18,70	18,70	18,70	19,40	21,50
		ft	-	-	61'4"	61'4"	61'4"	63'8"	70'6"
	Impianto oleodinamico - Hydraulic system - Circuit hydraulique - Hydraulikanlage - Sistema hidráulico portata raccomandata - recommended oil flow - débit recommandé - empfohlene Fördermenge - caudal requerido	l/min	30	30	30	30	30	30	
		gals/min	8	8	8	8	8	8	
	pressione massima - rated pressure - pression max - Betriebsdruck - presión máxima	Mpa	27,5	27,5	27,5	27,5	27,5	27,5	
		Psi	3990	3990	3990	3990	3990	3990	
	capacità del serbatoio - tank capacity - capacité du réservoir - Tankinhalt - capacidad del depósito de aceite	l	88	88	88	88	88	88	
	Gals	23	23	23	23	23	23		
	Gruppo di rotazione - Slewing system - Rotation - Schwenksystem - Sistema de giro angolo di rotazione - slewing angle - angle de rotation - Schwenkbereich - ángulo de giro	°	400	400	400	400	400	400	
	coppia di rotazione - slewing moment - couple de rotation - Schwenkmoment momento de giro	kNm	14	14	14	14	14	14	
		ft lbs	10330	10330	10330	10330	10330	10330	
	pendenza massima di lavoro - max. working heel - devers max de travail - max Arbeitsneigung - inclinación máxima de trabajo	%(°)	8,7(5)	8,7(5)	8,7(5)	8,7(5)	8,7(5)	0	
	Peso della gru standard - Standard crane weight Poids de la grue standard - Eigengewicht - Peso de la grúa estandar Con serbatoio non rifornito - Empty oil tank - réservoir huile non garni - Leerer Öltank - depósito de aceite vacío	kg	1265	1350	1436	1512	1576	1710	
		lbs	2790	2980	3170	3335	3470	3770	
	Versione LC - LC version - LC version - LC Version - versión LC	kg	1345	1430	1518	1592	-	-	
		lbs	2965	3150	3350	3510	-	-	