

**Tech
Spec**

RT-300-C

**30,000 Pounds
at 10' Radius**

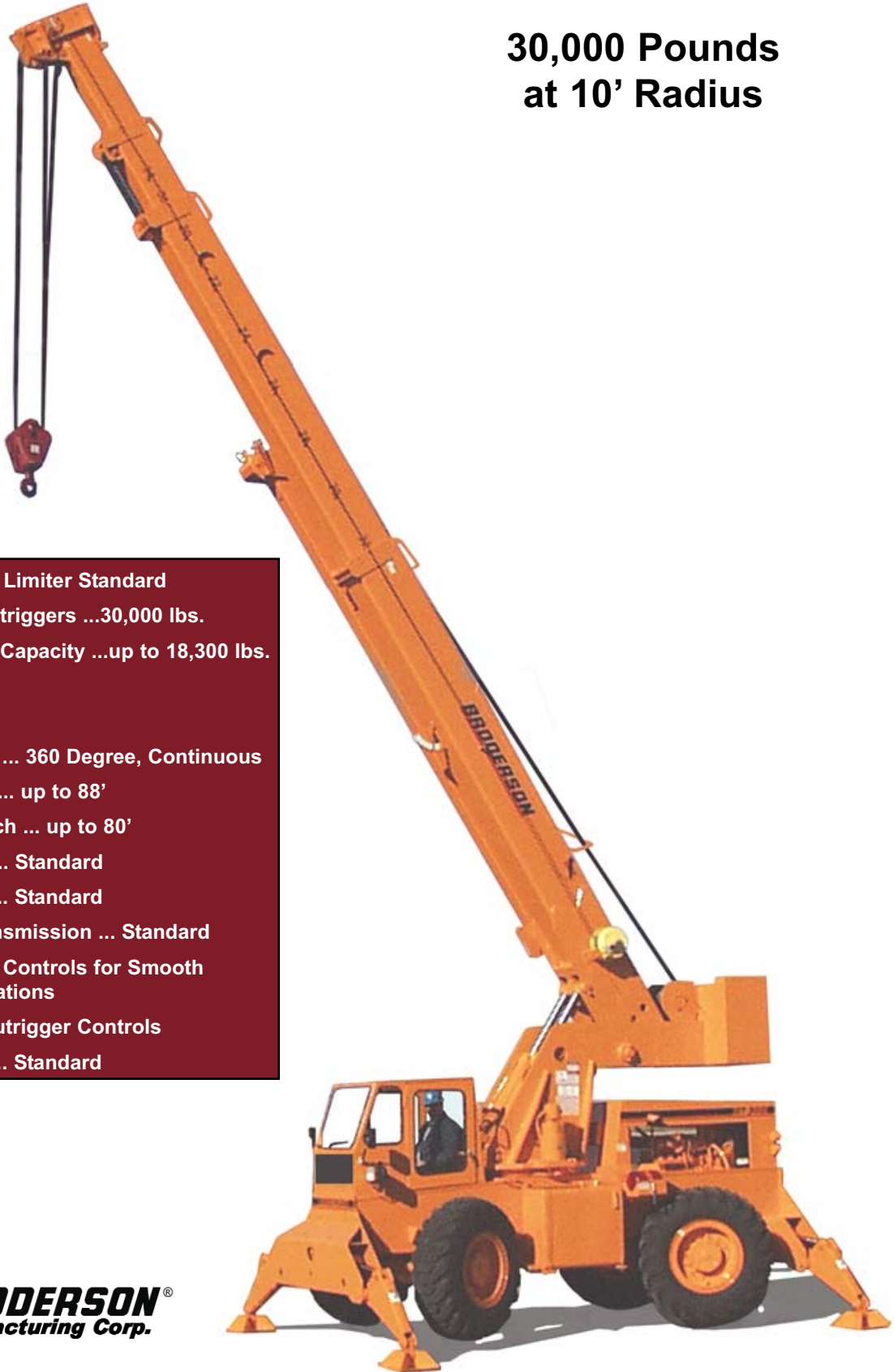

- Rated Capacity Limiter Standard
- Capacity on Outriggers ...30,000 lbs.
- Pick and Carry Capacity ...up to 18,300 lbs.
- Height ... 11' 2"
- Width ... 8' 2"
- Boom Rotation ... 360 Degree, Continuous
- Sheave Height ... up to 88'
- Horizontal Reach ... up to 80'
- 4-Wheel Drive ... Standard
- 4-Wheel Steer ... Standard
- Powershift Transmission ... Standard
- Fully Hydraulic Controls for Smooth Precise Operations
- Independent Outrigger Controls
- Diesel Engine ... Standard

DMC[®] BRODERSON[®]
Manufacturing Corp.

RT-300-2C

CAPACITIES APPLY TO OPERATION ON FIRM LEVEL SURFACE

LOAD RADIUS FEET	MAIN BOOM CAPACITIES IN POUNDS			
	360° ROTATION		OVER FRONT	
	ON RUBBER	ON OUTRIGGERS	ON RUBBER	ON OUTRIGGERS
10	18300	30000	26300	30000
12	13500	28500	22500	28500
14	10400	25900	17600	25900
16	8300	22500	14000	22500
18	6700	19500	11400	19500
20	5500	16900	9400	17000
22	4500	14200	7900	15000
24	3700	12100	6800	13300
26	3100	10500	5700	11900
28	2500	9100	4800	10600
30	2000	7900	4200	9600
32	1600	6900	3600	8600
34	1400	6300	3200	8000
36	1200	5700	2900	7500
38	900	5200	2600	6900
40	800	4800	2400	6500
44	600	4100	1900	5600
48	----	3500	1600	4900
52	----	3100	1300	4200
56	----	2700	1000	3700
60	----	2300	800	3200
64	----	1950	----	2300
68	----	1750	----	2300
72	----	1500	----	2250
76	----	1300	----	1950
80	----	1000	----	1600

CAPACITIES ON OUTRIGGERS ARE 85% OF TIPPING LOADS – ON RUBBER 75% OF TIPPING. CAPACITIES ABOVE BOLD LINES ARE LIMITED BY STRUCTURAL OR HYDRAULIC CAPABILITIES. CAPACITIES BELOW BOLD LINES ARE LIMITED BY TIPPING. DO NOT POSITION BOOM AT LOAD RADII WHERE NO LOAD CAPACITIES ARE SHOWN.

20 FOOT - BOOM EXTENSION CAPACITIES

BOOM EXTENSION OFFSET ANGLE	MAIN BOOM ANGLE						
	0°	15°	30°	40°	50°	60°	70°
0°	2300	2400	2700	3100	3700	4800	6200
15°	0	2300	2400	2600	2900	3400	4100
30°	0	0	2300	2400	2500	2700	3100

CAUTION: BOOM EXTENSION LOADS MUST NOT EXCEED MAIN BOOM CAPACITY.
BOOM EXTENSION DEDUCT: 500 LBS. WHEN STOWED ON BASE BOOM.
1000 LBS. IN WORK POSITION WITH LOAD ON MAIN BOOM.

LOAD HOIST ROPE

1/2" 6 X 25 IWRC ROPE WITH MIN. BREAKING STRENGTH OF 13.3 TONS (26,600 LBS.)



USE SINGLE PART LOAD LINE FOR LOADS TO 7500 LBS.

180 LBS.



USE FOUR PART LOAD LINE FOR LOADS TO 30000 LBS.

440 LBS.

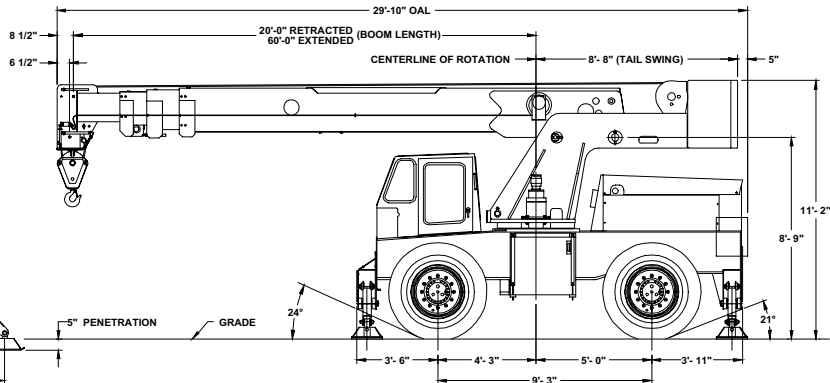
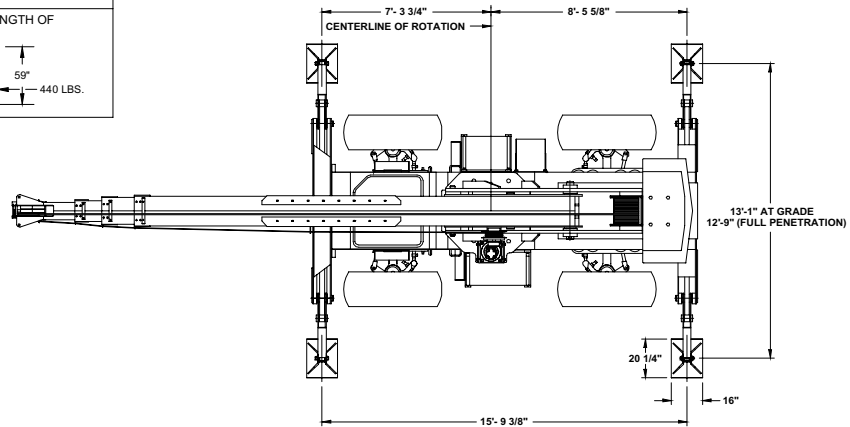
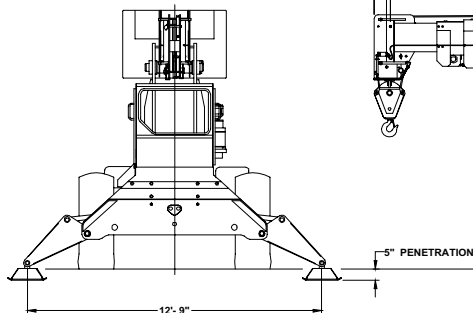
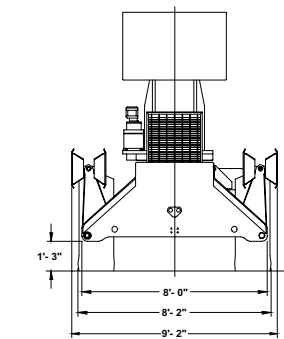
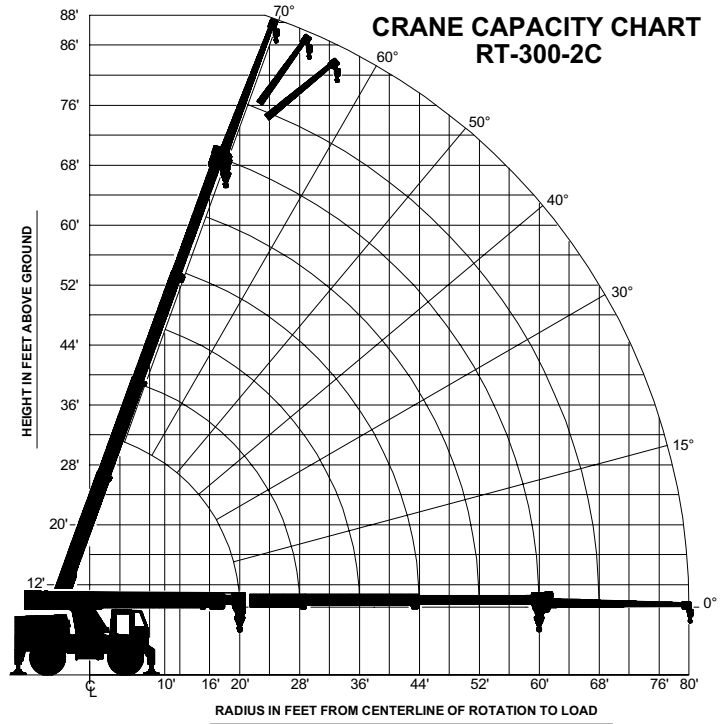

Tech Spec

GENERAL:

Weight:	RT-300-2C
Total	44,000 lbs.
Front Axle	23,300 lbs.
Rear Axle	20,700 lbs.
Angle of Approach	26 Degrees
Angle of Departure	24 Degrees
Gradeability	70 Percent Grade
Turning Radius: 4-Wheel Steer: (Min.)	
Outside Tire C/L Radius	15 Feet 3 Inches
Vehicle Clearance Circle (Dia.)	35 Feet 0 Inches
Drawbar Pull	30,000 pounds
Road Speed	24 Miles Per Hour (Max.)

ENGINE:

Make	Cummins
Model	QSB 5.9 Turbo
Type	Turbo Diesel
C.I.D.	5.9L
Max. Torque	440 @ 1500 RPM
Rated HP	155 @ 2500 RPM
FUEL TANK:	50 Gallon Capacity

TRANSMISSION

Make	Funk	
Model	2000	
Type	6-Speed Powershift With Torque Converter, Oil Cooler and Filter	
Gear Ratios:	Forward	Reverse
First	8.20:1	8.20:1
Second	4.64:1	3.53:1
Third	3.53:1	1.41:1
Fourth	2.00:1	
Fifth	1.41:1	
Sixth	.80:1	

AXLES:

Front and Rear Axles:	
Make	Axle Tech
Gear Ratio	20.06:1

BRAKES:

Service - 4-Wheel Drum Type with Hydraulic Booster
Parking - Spring-Applied and Hydraulically-Released Mounted On Transmission

STEERING:

Hydraulic steering unit with two 3.5 inch cylinders attached to each axle. Allows limited steering when engine is not running. A switch on the control panel is used to select front-wheel steering, 4-wheel steering or crab steering. Electronic sensors and control box automatically align the steering when a new mode is selected.

TIRES:

Standard - 17.5 x 25, 20-Ply Rating Mud Lug.

CHASSIS:

Outriggers:

Four independently controlled outriggers of swing-down design. Hydraulic cylinders are equipped with direct-connected holding valves.

OPERATOR'S COMPARTMENT:

Operator control station provides one-position access to all chassis and crane controls.

ELECTRICAL SYSTEM:

12 Volt DC System

Instrument Group:

Fuel, transmission oil temperature, voltmeter, engine oil pressure, water & hydraulic oil temperature gauges and hourmeter.

Outrigger Alarm System:

Two-tone alarm is activated when "outrigger down" controls are operated.

HYDRAULIC SYSTEM:

Triple vane pump, mounted and driven by main transmission. Rated 9, 26 and 44 GPM at 3,000 PSI at 2,500 RPM engine speed. Hydraulic oil tank capacity of 70 gallons.

BOOM ASSEMBLY:

	Boom Movement	Boom Speeds
Rotation	Continuous	3.5 RPM
Elevation	0 - 70 Degrees	18 Seconds
Extension	40 Feet	23 Seconds

Boom Assembly:

Boom assembly equipped with bearing pads. Double-acting hydraulic cylinders, equipped with a holding valve, extend and retract the second and third boom sections. Double runs of high strength leaf chain extend and retract the fourth section. Boom angle indicator included on left side of boom. Twin, double-acting hydraulic cylinders control the boom elevation and are equipped with direct-connected holding valves.

Boom Rotation:

Heavy-duty ball bearing rotation gear with external teeth. Rotation is powered by hydraulic motor and compound planetary gear drive. A spring-applied hydraulically released brake and an overrunning load valve are provided. Hydraulic centerpost and electric slip rings allow continuous rotation.

Boom Hoist:

Turret Mounted	
Hydraulic Powered	
Bare Drum Line Pull	10,000 Pounds
Wire Rope	375 Feet of 1/2 inch dia.
Line Speed:	
Bare Drum	280 FPM
Full Drum	360 FPM

4-Part-Line Sheave Block:

Double sheave block for four-part-line requirements.

Anti-Two-Block Device:

Prevents damage to hoist rope and/or machine components from accidentally pulling load hook against boom tip.

Rated Capacity Limiter

Warns operator of impending overload with audible and visual signals. Prevents overloads by stopping boom functions that cause overloads. Displays boom length, angle, load radius, load and capacity.

RT-300-C

Listed below are brief descriptions of each option available for the RT-300-2C Rough Terrain Crane. Consult the RT-300-2C Engineering Spec for additional information on each option.

ENGINE OPTIONS:

Engine Heater

Engine coolant heater installed to circulate warm water through engine, plugs into 120 volt AC.

Ether Injection System

Ether starting aid controlled by switch in operator's compartment and injects ether directly into intake manifold.

Engine Side Covers

Quick detach, to fit fixed hood and grille.

TIRE OPTIONS:

Spare Wheel & Tire:

17.5 x 25, 20-Ply Tire

CHASSIS OPTIONS:

Lifting Eyes

Lifting eyes on corners of chassis and turntable so slings can be attached for lifting crane.

Towing Eyes

Consists of four eyes, two on front and two on rear for towing.

Spreader Bar & Sling Assembly:

Spreader bar with four wire rope assemblies to allow balanced lifting of crane. Must be used with lifting eyes (ordered separately).

Pintle Hook, Front

Pintle hook mounted on front outrigger housing, 24 ton capacity.

Pintle Hook, Rear

Pintle hook mounted on rear outrigger housing, 24 ton capacity.

OPERATOR'S COMPARTMENT OPTIONS:

All Weather Cab

Consists of rigid-mounted canopy section and two removable hinged doors. Includes heater with two-speed fan, 12-volt electric windshield wiper. Defroster fan included.

Window Wiper - Top Window

12-volt electric wiper on top window operated with its own switch.

Operator Guard

Tubular steel weldment with heavy expanded steel mesh top & grille front section.

Operator's Suspension Seat Seats Inc. - Cloth

Full-suspension with adjustments for height, tilt, fore/aft, operator weight with armrest angle adjustment.

Operator's Suspension Seat Seats Inc. - Vinyl

Full-suspension with adjustments for height, tilt, fore/aft, operator weight with armrest angle adjustment.

Noise Reduction Kit

Consists of noise reduction panel over control valves and grille on front of unit to vent heat from valve area.

Air Conditioning

Air Conditioning with R134 coolant.

ELECTRICAL OPTIONS:

Strobe Light

Yellow strobe light mounted on top of engine hood for high visibility.

Lighting Kit

Includes two modular, dual-beam headlights with turn signal lights. Taillights with brake & turn signal lights. Back-up lights & lights installed in back of instrument gauges.

Amber Rotating Beacon

Amber rotating beacon mounted on top of engine hood for high visibility.

Boom Work Lights

One halogen work light mounted to boom to light boom tip and one work light mounted to turret to light ground under boom tip.

BOOM ATTACHMENT OPTIONS:

20 Ft. Offsettable Boom Extension

Boom stowable. Offsets include 0 (in-line), 15 or 30 degree. Downhaul weight & hook option required.

Downhaul Weight & Hook

Downhaul weight & 5-ton swivel hook to use with existing wedge socket for 1-part line.

Should you, as the end user, require an option or special equipment on your RT-300-2C that is not listed on our sales literature, please contact your dealer salesperson or the factory to receive a special quoted price.

BMC[®] BRODERSON[®]
Manufacturing Corp.
P.O. Box 14770, Lenexa, KS 66285-4770
(913) 888-0606 • FAX (913) 888-8431
website: bmccranes.com