

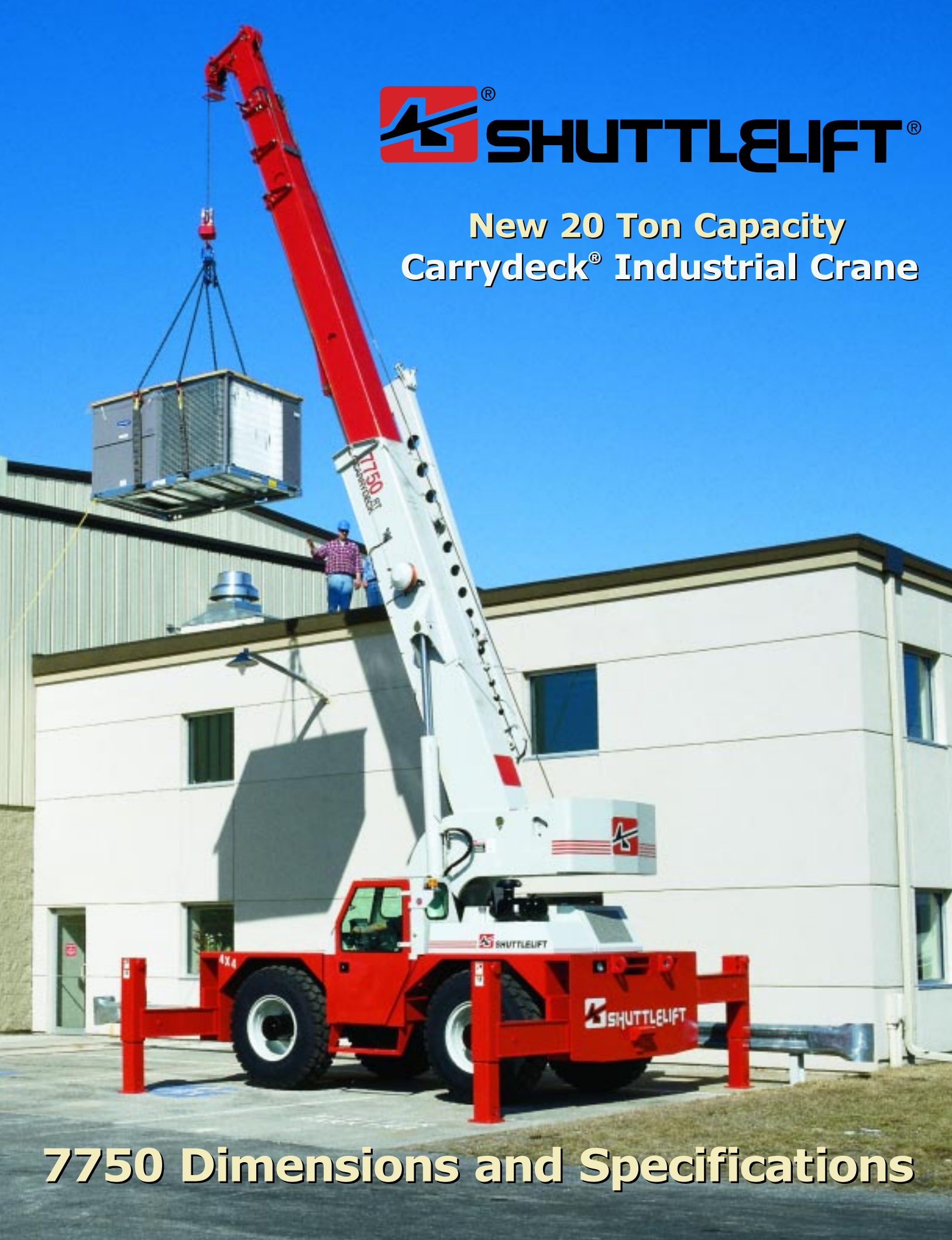

**New 20 Ton Capacity
Carrydeck® Industrial Crane**



7750 Dimensions and Specifications

Dimensional Data

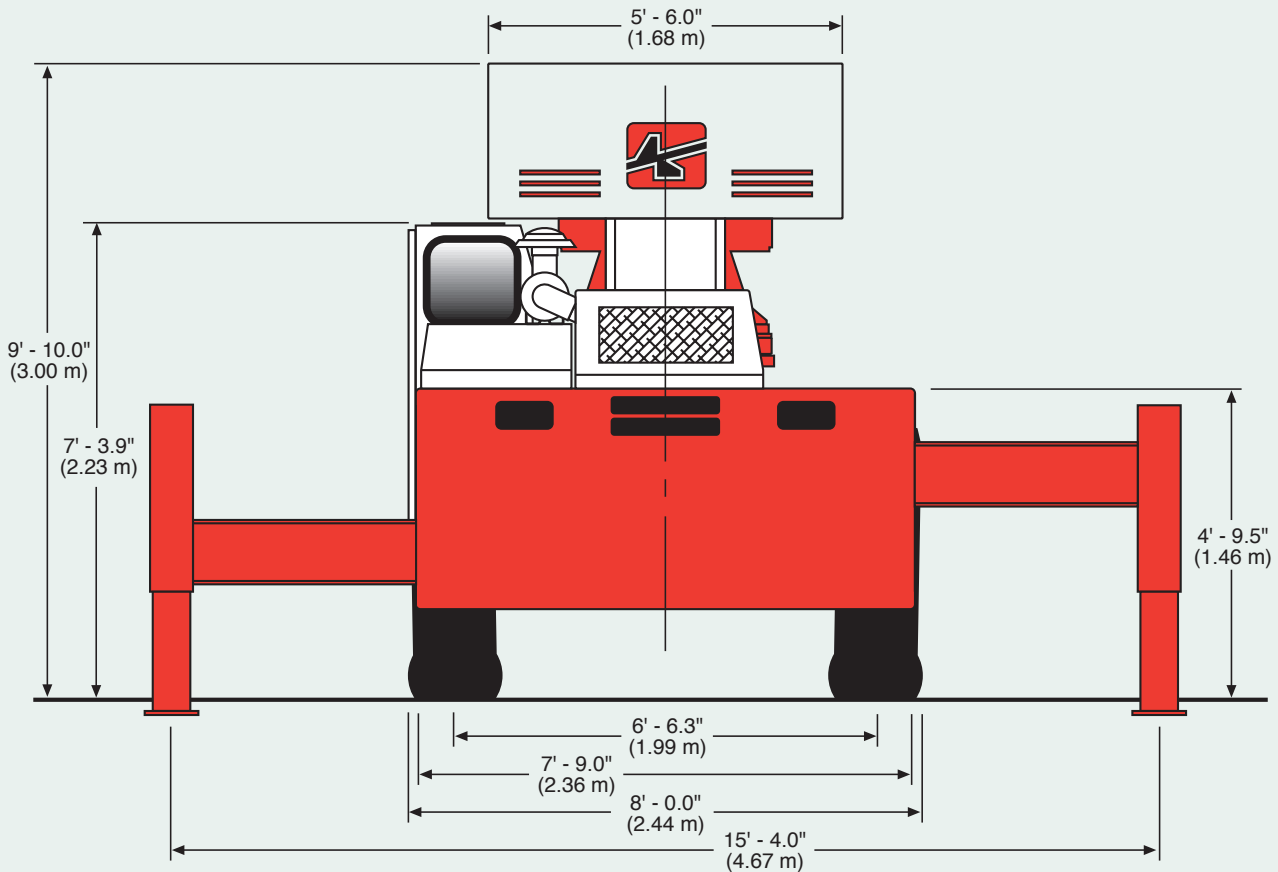
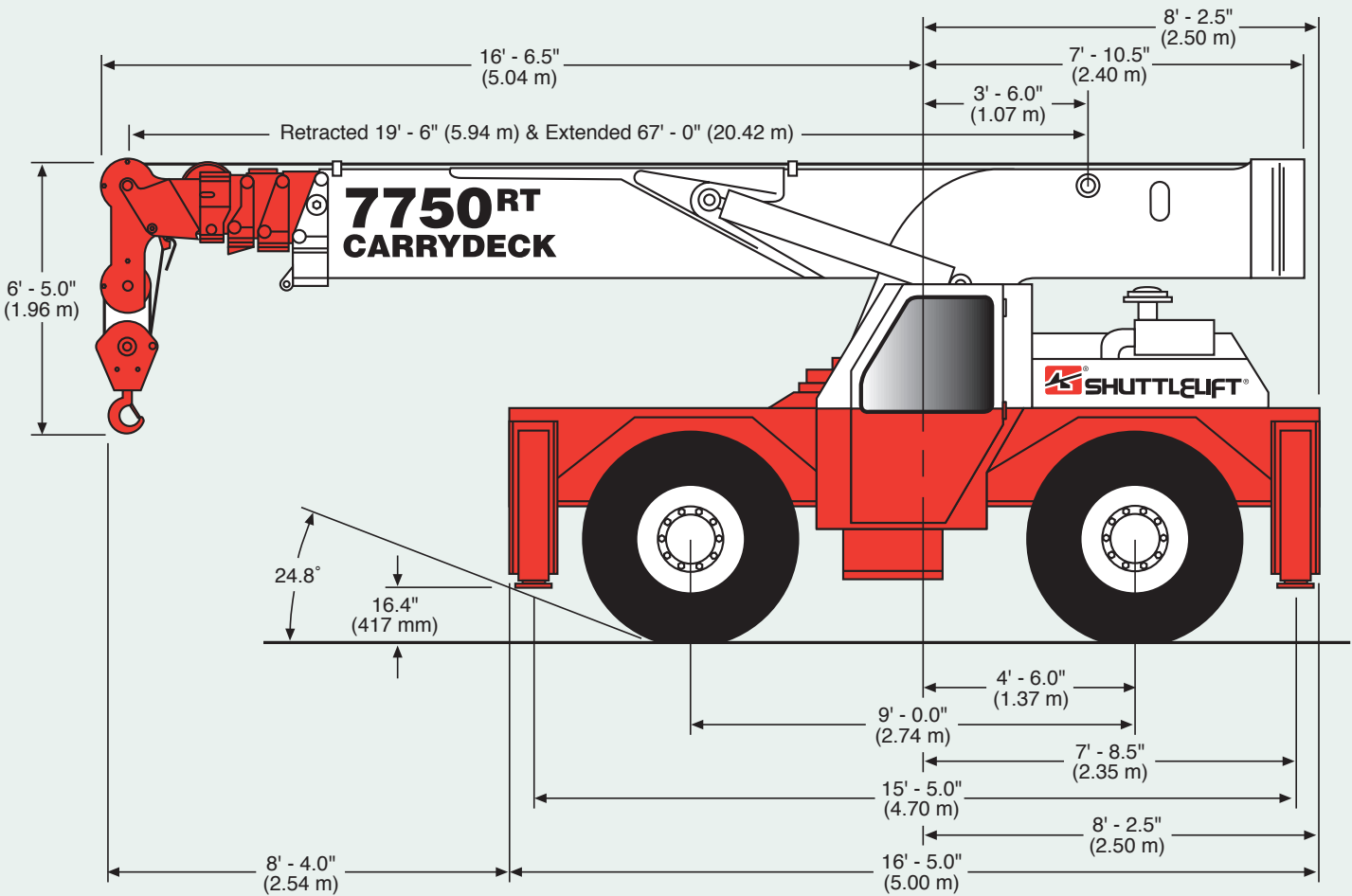

Rated Load Capacities

MAIN BOOM LOAD RATINGS ON OUTRIGGERS

Retracted and Down 360°

Radius ft (m)	19.5 ft (5.94 m) BOOM		31.0 ft (9.45 m) BOOM		43.0 ft (13.11 m) BOOM		55.0 ft (16.76 m) BOOM		67.0 ft (20.42 m) BOOM	
	Boom Angle (deg)	Rated Load lb (kg)	Boom Angle (deg)	Rated Load lb (kg)	Boom Angle (deg)	Rated Load lb (kg)	Boom Angle (deg)	Rated Load lb (kg)	Boom Angle (deg)	Rated Load lb (kg)
10 (3.05)	52	24,000 (10 886)	68	22,300 (10 115)	74	22,000 (9979)	78	22,000 (9979)	-	-
12 (3.66)	44	17,200 (7802)	64	16,300 (7394)	72	17,000 (7711)	76	17,100 (7756)	78	16,300 (7394)
14 (4.27)	33	13,300 (6033)	59	12,500 (5700)	69	13,600 (6169)	74	14,000 (6350)	77	13,600 (6169)
16 (4.88)	0	10,200 (4627)	55	9,800 (4445)	66	11,100 (5035)	71	11,200 (5080)	75	11,500 (5216)
18 (5.49)	-	-	50	7,900 (3583)	63	9,100 (4128)	69	9,300 (4218)	73	9,400 (4264)
20 (6.10)	-	-	45	6,500 (2948)	60	7,500 (3402)	67	7,800 (3538)	71	7,700 (3493)
22 (6.71)	-	-	39	5,300 (2404)	56	6,200 (2812)	64	6,600 (2994)	69	6,500 (2948)
24 (7.32)	-	-	31	4,300 (1950)	53	5,200 (2359)	62	5,600 (2540)	67	5,600 (2540)
26 (7.92)	-	-	22	3,500 (1588)	49	4,400 (1996)	60	4,800 (2177)	66	5,000 (2268)
27.5 (8.38)	-	-	0	2,900 (1315)	47	3,900 (1769)	58	4,300 (1950)	64	4,600 (2087)
30 (9.14)	-	-	-	-	42	3,200 (1451)	55	3,600 (1633)	62	3,900 (1769)
32 (9.75)	-	-	-	-	37	2,700 (1225)	52	3,100 (1406)	60	3,400 (1542)
34 (10.36)	-	-	-	-	32	2,300 (1043)	49	2,700 (1225)	58	2,900 (1315)
36 (10.97)	-	-	-	-	26	1,900 (862)	46	2,300 (1043)	56	2,500 (1134)
38 (11.58)	-	-	-	-	18	1,600 (726)	43	2,000 (907)	53	2,100 (953)
39.5 (12.04)	-	-	-	-	0	1,400 (635)	41	1,750 (794)	52	1,850 (839)
42 (12.80)	-	-	-	-	-	-	36	1,450 (658)	49	1,500 (680)
44 (13.41)	-	-	-	-	-	-	32	1,200 (544)	47	1,300 (590)
46 (14.02)	-	-	-	-	-	-	28	1,000 (454)	44	1,100 (499)
48 (14.63)	-	-	-	-	-	-	23	850 (386)	42	950 (431)
50 (15.24)	-	-	-	-	-	-	16	700 (318)	39	800 (363)
51.5 (15.70)	-	-	-	-	-	-	0	600 (272)	37	700 (318)
54 (16.46)	-	-	-	-	-	-	-	-	33	500 (227)
56 (17.07)	-	-	-	-	-	-	-	-	29	350 (159)
58 (17.68)	-	-	-	-	-	-	-	-	25	250 (113)
60 (18.29)	-	-	-	-	-	-	-	-	20	150 (68)
62 (18.90)	-	-	-	-	-	-	-	-	14	50 (23)
63.5 (19.35)	-	-	-	-	-	-	-	-	0	-

Main Boom on Rubber Any Boom Length

Radius ft (m)	Front Rating lb (kg)	360° Rating lb (kg)
6 (1.83)	30,000 (13 608)	21,000 (9525)
8 (2.44)	28,000 (12 701)	17,900 (8119)
10 (3.05)	25,000 (11 340)	15,000 (6804)
12 (3.66)	19,600 (8890)	12,400 (5625)
14 (4.27)	15,600 (7076)	9,900 (4491)
16 (4.88)	12,700 (5761)	7,700 (3493)
18 (5.49)	10,300 (4672)	6,300 (2858)
20 (6.10)	8,300 (3765)	4,900 (2223)
22 (6.71)	6,800 (3084)	3,900 (1769)
24 (7.32)	5,800 (2631)	3,100 (1406)
26 (7.92)	4,900 (2223)	2,500 (1134)
28 (8.53)	4,200 (1905)	2,100 (953)
30 (9.14)	3,700 (1678)	1,800 (816)
32 (9.75)	3,300 (1497)	1,550 (703)
34 (10.36)	3,000 (1361)	1,300 (590)
36 (10.97)	2,700 (1225)	1,100 (499)
38 (11.58)	2,500 (1134)	950 (431)
40 (12.19)	2,200 (998)	800 (363)
42 (12.80)	2,000 (907)	675 (306)
44 (13.41)	1,800 (816)	550 (249)
46 (14.02)	1,650 (748)	450 (204)
48 (14.63)	1,400 (635)	350 (159)
50 (15.24)	1,300 (590)	250 (113)
52 (15.85)	1,150 (522)	200 (91)
54 (16.46)	1,050 (476)	150 (68)
56 (17.07)	950 (431)	75 (34)
58 (17.68)	875 (397)	25 (11)
60 (18.29)	800 (363)	-
62 (18.90)	700 (318)	-
63.5 (19.35)	600 (272)	-

Rating Reductions for Load Handling Devices Installed lb (kg)

	FROM MAIN BOOM	FROM JIB
MAIN BLOCK	400 (181)	NOT APPLICABLE
HOOK & BALL	100 (45)	100 (45)
JIB STOWED	NO REDUCTION	NOT APPLICABLE
JIB DEPLOYED	500 (227)	NO REDUCTION

* This chart is only a guide and should not be used to operate the crane. The individual crane load chart, operating instructions and other instructional plates must be read and understood prior to operating the crane.

7750RT FEATURES:

- Two-position square outrigger stance
- 20 ton lift capacity
- 15 ton deck carrying capacity
- Extremely compact
- Pivoting boom head
- Pressure compensated hydraulic system
- Pilot-operated crane controls
- 4-wheel drive w/oscillating rear axle lockouts
- One year/2000 hour warranty (5-year structure)
- 90' (27.43 m) maximum hook height with optional jib boom extension

Rated Load Capacities

MAIN BOOM LOAD RATINGS ON OUTRIGGERS										
Extended and Down 360° or Retracted and Down Front/Rear										
	19.5 ft (5.94 m) BOOM		31.0 ft (9.45 m) BOOM		43.0 ft (13.11 m) BOOM		55.0 ft (16.76 m) BOOM		67.0 ft (20.42 m) BOOM	
Radius ft (m)	Boom Angle (deg)	Rated Load lb (kg)	Boom Angle (deg)	Rated Load lb (kg)	Boom Angle (deg)	Rated Load lb (kg)	Boom Angle (deg)	Rated Load lb (kg)	Boom Angle (deg)	Rated Load lb (kg)
10 (3.05)	52	40,000 (18 144)	68	26,500 (12 020)	74	25,400 (11 521)	78	22,300 (10 115)	-	-
12 (3.66)	44	33,800 (15 331)	64	25,300 (11 476)	72	24,200 (10 977)	76	20,100 (9117)	78	17,500 (7938)
14 (4.27)	33	28,500 (12 927)	59	22,900 (10 387)	69	22,600 (10 251)	74	18,000 (8165)	77	15,600 (7076)
16 (4.88)	0	23,700 (10 750)	55	20,900 (9480)	66	20,000 (9072)	71	16,300 (7394)	75	14,000 (6350)
18 (5.49)	-	-	50	19,300 (8754)	63	17,900 (8119)	69	14,900 (6759)	73	12,700 (5761)
20 (6.10)	-	-	45	17,800 (8074)	60	16,100 (7303)	67	13,700 (6214)	71	11,700 (5307)
22 (6.71)	-	-	39	16,400 (7439)	56	14,600 (6622)	64	12,700 (5761)	69	10,800 (4899)
24 (7.32)	-	-	31	14,700 (6668)	53	13,300 (6033)	62	11,800 (5352)	67	10,000 (4536)
26 (7.92)	-	-	22	13,200 (5987)	49	12,300 (5579)	60	11,000 (4990)	66	9,300 (4218)
27.5 (8.38)	-	-	0	11,600 (5262)	47	11,600 (5262)	58	10,400 (4717)	64	8,800 (3992)
30 (9.14)	-	-	-	-	42	10,500 (4763)	55	9,400 (4264)	62	8,100 (3674)
32 (9.75)	-	-	-	-	37	9,800 (4445)	52	8,700 (3946)	60	7,600 (3447)
34 (10.36)	-	-	-	-	32	8,700 (3946)	49	8,100 (3674)	58	7,200 (3266)
36 (10.97)	-	-	-	-	26	7,800 (3538)	46	7,600 (3447)	56	6,800 (3084)
38 (11.58)	-	-	-	-	18	7,000 (3175)	43	7,100 (3221)	53	6,500 (2948)
39.5 (12.04)	-	-	-	-	0	6,400 (2903)	41	6,800 (3084)	52	6,300 (2858)
42 (12.80)	-	-	-	-	-	-	36	6,300 (2858)	49	5,900 (2676)
44 (13.41)	-	-	-	-	-	-	32	5,800 (2631)	47	5,600 (2540)
46 (14.02)	-	-	-	-	-	-	28	5,300 (2404)	44	5,300 (2404)
48 (14.63)	-	-	-	-	-	-	23	4,800 (2177)	42	5,000 (2268)
50 (15.24)	-	-	-	-	-	-	16	4,400 (1996)	39	4,700 (2132)
51.5 (15.70)	-	-	-	-	-	-	0	4,000 (1814)	37	4,600 (2087)
54 (16.46)	-	-	-	-	-	-	-	-	33	4,200 (1905)
56 (17.07)	-	-	-	-	-	-	-	-	29	3,900 (1769)
58 (17.68)	-	-	-	-	-	-	-	-	25	3,600 (1633)
60 (18.29)	-	-	-	-	-	-	-	-	20	3,300 (1497)
62 (18.90)	-	-	-	-	-	-	-	-	14	3,000 (1361)
63.5 (19.35)	-	-	-	-	-	-	-	-	0	2,800 (1270)

17' (5.18 m) JIB CAPACITIES ON EXTENDED OUTRIGGERS					
Jib Offset Angle					
	0 degrees		15 degrees		30 degrees
Main Boom Angle (deg)	To 55.0 ft (16.8 m) Main Boom lb (kg)	To 67.0 ft (20.4 m) Main Boom lb (kg)	To 55.0 ft (16.8 m) Main Boom lb (kg)	To 67.0 ft (20.4 m) Main Boom lb (kg)	Any Boom Length lb (kg)
80	-	-	5,000 (2268)	5,000 (2268)	3,500 (1588)
75	7,500 (3402)	-	4,400 (1996)	4,400 (1996)	3,100 (1406)
70	6,100 (2767)	-	3,900 (1769)	3,900 (1769)	2,800 (1270)
65	5,000 (2268)	4,600 lb (2087)	3,500 (1588)	3,500 (1588)	2,550 (1157)
60	4,300 (1950)	3,800 lb (1724)	3,150 (1429)	3,150 (1429)	2,350 (1066)
55	3,800 (1724)	3,300 (1497)	2,850 (1293)	2,850 (1293)	2,200 (998)
50	3,400 (1542)	2,900 (1315)	2,600 (1179)	2,600 (1179)	2,100 (953)
45	3,050 (1383)	2,600 (1179)	2,400 (1089)	2,400 (1089)	2,000 (907)
40	2,800 (1089)	2,400 (1021)	2,250 (1021)	2,250 (1021)	1,950 (885)
35	2,600 (1179)	2,150 (975)	2,150 (975)	2,050 (930)	1,900 (862)
30	2,400 (1089)	1,930 (875)	2,080 (943)	1,850 (839)	-
25	2,300 (1043)	1,750 (794)	2,050 (930)	1,720 (780)	-
20	2,200 (998)	1,600 (726)	2,000 (907)	1,590 (721)	-
15	2,100 (953)	1,500 (680)	1,950 (885)	1,520 (689)	-
10	2,050 (930)	1,460 (662)	-	-	-
5	2,020 (916)	1,450 (658)	-	-	-
0	2,000 (907)	1,440 (653)	-	-	-

Shaded areas are governed by structural strength, do not rely on tipping.

WIRE ROPE: 9/16" diameter (14 mm) 6 x 19 EEIPS IWRC BRIGHT

Minimum required breaking strength = 37,000 lb (16 783 kg)

Maximum permissible single line pull = 10,000 lb (4536 kg)

7750 General Specifications

STANDARD EQUIPMENT

- 19' 6"-67' 0" (5.94 m-20.42 m) five-section full power boom
- Quick reeve dropplock with swing/swivel hook
- Hydraulic oscillating rear axle lockouts
- 4-wheel drive & 4-wheel steer
- 60 ft² (18.29 m²) carrydeck
- All steel cab structure less glass (top safety plate standard)
- Lights - head, tail, rear, work, stop & turn signals
- Outriggers - two-stage hydraulic telescoping box-front & rear
- Power steering - hydraulic, load sense
- 375' x 9/16" diameter 6 X 19 EEIPS wire rope
- Anti-two block cut-out for telescope, boom, & hoist
- Pivoting boom head
- 14.00R24 tires
- Independent outrigger control
- Cummins 4BTA 3.9 diesel engine
- Non-skid deck surface
- Backup alarm
- Boom angle indicators
- Pilot-operated controls
- Dual rearview mirrors

OPTIONAL EQUIPMENT

- Enclosed cab with windshield wiper & sliding right window
- Adjustable operator cushion seat with seat belt
- 17.5R25 tires
- CE compliance

ACCESSORIES & ATTACHMENTS

- Cold start kit
- Flashing strobe light
- Rear hitch
- Front hitch
- 17' (5.18 m) offsettable/swingaway boom extension
- Heater & defroster
- Spare wheel & tire
- Engine shut-down gauges
- 5 ton overhaul ball
- LMI indicator system
- Recessed auxiliary winch (hydraulic)
- Head & tail light grilles
- Foam-filled tires
- Lift & tie-down lugs
- Catalytic converter for diesel
- Fire extinguisher
- Air-conditioned cab
- Two-man work platform

CAPACITIES

Fuel tank..... 50 gal (189L)
 Hydraulic reservoir 60 gal (227L)
 Cooling system 23 qts (21.9L)
 Transmission..... 6 gal (22.7L)

GENERAL

Unit weight (approximate) 43,000 lb (19 504 kg)
 Maximum boom angle 80°
 Outrigger pad size..... 11.5" X 11.5" (29.21 cm X 29.21 cm)
 Swing system 360° continuous rotation
 Swing speed 2.5 rpm

HYDRAULIC SYSTEM

Main pump..... Variable displacement piston pump with fixed displacement gear pump
 Maximum system pressure 3500 psi
 Maximum flow..... 74 gpm (280 Lpm) @ 2500 rpm

ENGINE

Make & model..... Cummins 4BTA3.9 diesel
 Number of cylinders..... 4
 Horsepower..... 130 @ 2500 rpm (97kW)
 Torque..... 344 lb-ft @ 1500 rpm (156 N·m)

TRANSMISSION

Type..... 4-speed powershift
 Parking brake SAHR caliper disc

AXLES

Drive/steer front and rear:

Type planetary
 Service brakes..... integrated wet disc
 Oscillating rear axle 3.5°

ELECTRICAL

Starting 12 VDC
 Battery (1) 820 CCA @ 0°F (-18°C)
 Alternator 63 amp

DECK CARRYING CAPACITIES

Deckload only 30,000 lb (13 608 kg)
 Combined boom & deckload 20,000 lb (9072 kg)

TRAVEL SPEEDS

1st gear 2.9 mph (4.66 k/h)
 2nd gear 6.5 mph (10.45 k/h)
 3rd gear 14.3 mph (22.99 k/h)
 4th gear 19.5 mph (31.35 k/h)

TURNING SPECIFICATIONS

Turning radius: to c/l of outside tires
 2-wheel steer 24' 0" (7.3 m)
 4-wheel steer 13' 3" (4.0 m)

TRACTIVE EFFORT

Unit equipped with 14.00R24 tires and no load.
 1st gear 28,400 lb (12 882 kg)
 2nd gear 13,500 lb (6124 kg)
 3rd gear 6,150 lb (2790 kg)
 4th gear 4,300 lb (1950 kg)

GRADEABILITY (calculated)

(PAVED SURFACE)

1st gear, no load 63%
 30,000 lb (13 608 kg) load 38%

CYLINDERS

	Cycle Time	
	1000 rpm	2500 rpm
Boom cylinder (full stroke):		
Up	49 sec.	49 sec.
Down	32 sec.	32 sec.
Telescope cylinder (full stroke):		
Out	120 sec.	59 sec.
In	70 sec.	58 sec.
Outriggers (simultaneous operation):		
Out	12 sec.	4 sec.
In	6 sec.	5 sec.
Down	28 sec.	11 sec.
Up	20 sec.	8 sec.

Hoist (winch):

2-speed:

Line pull..... 10,000 lb (4535 kg)
 Rope size 9/16" x 375' (14 mm x 114 m)

Line speed (2nd layer):

1,000 rpm 84/114 fpm (25.6 m/34.7 m)
 2,500 rpm..... 174/335 fpm (50 m/102.1 m)

NOTE: All specifications are stated in accordance with PCSA definition, ANSI B30.5 standards, or recommended practices where applicable.

IMPORTANT: Shuttlelift reserves the right to change specifications without notice and without incurring any obligation relating to such changes.



SHUTTLELIFT, INC., 49 E. Yew St., P.O. Box 66, Sturgeon Bay, WI 54235 USA

Ph: 920-743-8650 • FAX: 920-743-1522 • E-mail: sales@shuttlelift.com

www.shuttlelift.com