

PK 50002 EH

High Performance

PALFINGER CRANE

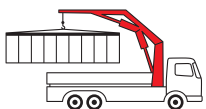

KTL
protected

**Paltronic
50**
controlled

RRC
Radio Remote Control
operated

ISC
Integrated Stability Control
monitored

AOS
Active Oscillation Suppression
inside

DPS
Dual Power System
activated

The perfect introduction to the heavy-duty range

Innovative *High Performance*

The PK 50002 EH is a milestone in crane development. Its innovative and user-friendly design, high payload and enormous hydraulic out-reach will tell you why. These qualities make it the ideal crane for assembly work – but it's also the perfect all-rounder. Its double slewing drive enables a large slewing torque and very precise crane movements. The fly-jibs can be equipped with the new "DPS Plus". And last but not least, maximum service friendliness rounds out the profile of this exceptional crane by PALFINGER.



Operator-friendly product design



Endless slewing mechanism with two slewing drives



Power Link Plus

This knuckle boom, specially developed by PALFINGER which can be angled upwards stands out by virtue of excellent movement geometry. Even in the tightest spaces difficult crane jobs can be performed with precision.



Maintenance-free extension system

With the maintenance-free extension system PALFINGER sets a clear path in easy servicing. The use of sliding elements made of special plastic in combination with the proven KTL cathodic dip painting means that the extension boom system no longer has to be serviced by the operator. This not only saves time and expense but also protects the environment.



Operator Panel for Stabilizer Control

All important information about the crane is visible on the operator panel. The operating hours are counted and displayed via a digital display. The box level is visible from all sides. The control valves for crane and auxiliary stabilizers are mounted on the base frame as standard.



Cable winch and Comfort Cable Routing

The 2.5 t or 3.5 t cable winch on the main boom for use in combination with the fly-jib is available as a hydraulically tilted version and can be operated comfortably via the radio remote control. The lower overall height due to tilting is beneficial for crane applications inside buildings and during transport when the crane boom is not folded down. The cable on the winch is also guided laterally as standard and as a result no longer needs to be detached on folding down the crane.



Endless slewing mechanism

The endless slewing mechanism with slewing ring, permits an unrestricted radius of operation and produces a high slewing torque. As a result crane operations are faster and more efficient. Two slewing drives are standard for cranes with more than four hydraulic extensions!

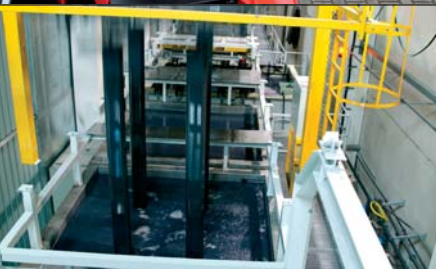

KTL – the cathodic dip painting

The shot-blasted crane parts are covered in zinc phosphate in an immersion process and coated electro-statically. The subsequent two-component top coating of paint provides a surface protection which in the past was usually only found in the automotive industry.



AOS (optional)

The Active Oscillation Suppression system available exclusively from PALFINGER compensates for jolts and sharp stress cycles caused by crane operation. Because oscillations are eradicated the crane can work with precision, much faster and therefore more cost-efficiently.

Perfect all-rounder

ISC (optional)*

The integrated stability control (ISC) is a system that monitors the stability of the crane vehicle. The system adjusts the crane's lifting forces depending on the current stability support situation and the crane boom to ensure the vehicle's stability over the entire working area.

* ISC or an alternative system for monitoring stability is mandatory in the version compliant with EN12999:2009.

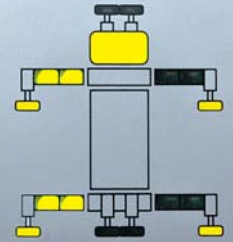

Return oil utilisation

The high speed of the extension system is impressive. It results from return oil utilisation, which is installed as standard, and the generously dimensioned hydraulic lines. This increases efficiency in all types of applications!



Outriggers and stabilizers that can be tilted upwards

The standard 7.8 m (25' 7") outriggers ensure good stability. All the outriggers are fitted as standard with a ball-jointed support plate that can be swivelled through 10°. This enables them to adapt optimally to the ground. The enlarged plate also reduces the pressure on the ground. The crane's stabilizer cylinders can be tilted fully hydraulically upwards through 180° (optional equipment) and are fitted with LED warning lights.



Hose equipment for auxiliary equipment

Hoses providing oil supply for auxiliary equipment are routed in compact trays and protective chains. A clean design offering maximum service life.



Advanced Package

- E-HPLS
- Paltronic 50
- Radio remote control with LED display
- Danfoss control valve PVG2000



Internally routed hose guide on the main boom

The hydraulic hoses between the main and outer booms are internally routed. This invention, which is to be patented, provides protection against dirt and damage.



Functional Design

Synthetic covers protect sensitive crane components against dirt and impact. That reduces service and maintenance time and greatly extends the life of your loading crane. Integrating the oil tank on the base helps to save space. Additional room for installation on the chassis is no longer necessary.



Pinpoint accuracy and oscillation-free due to AOS

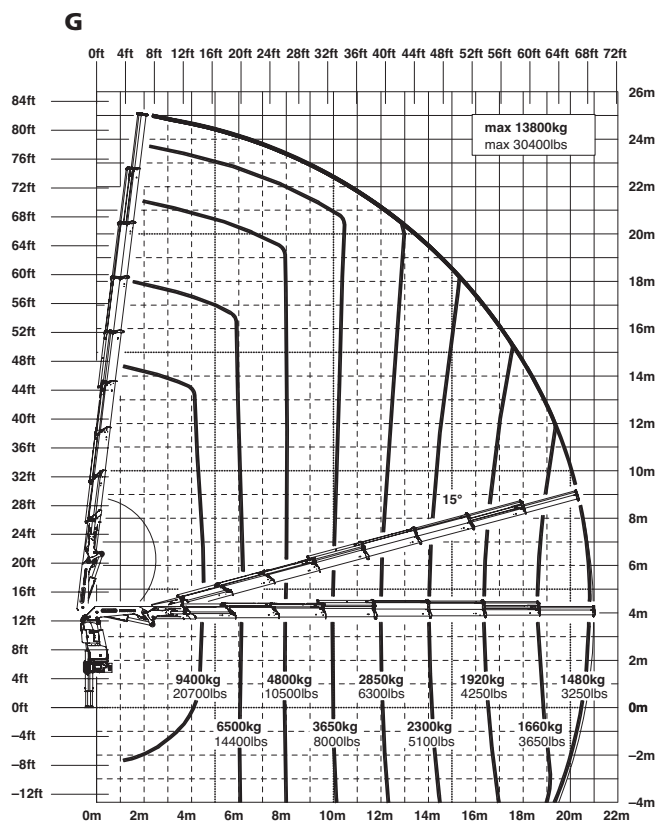
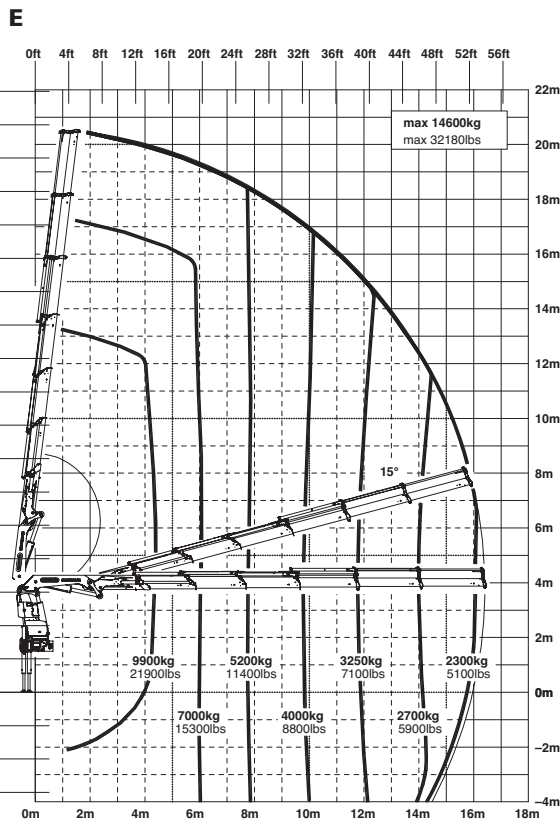
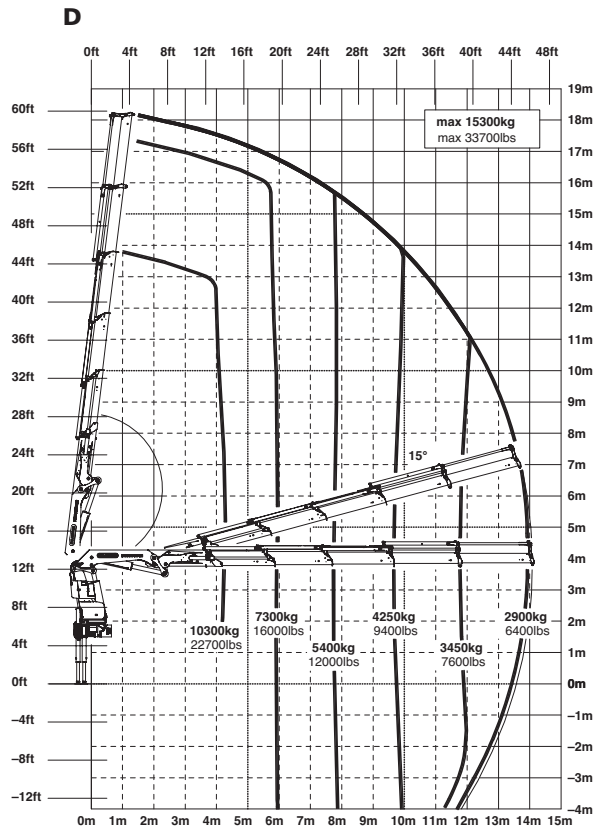
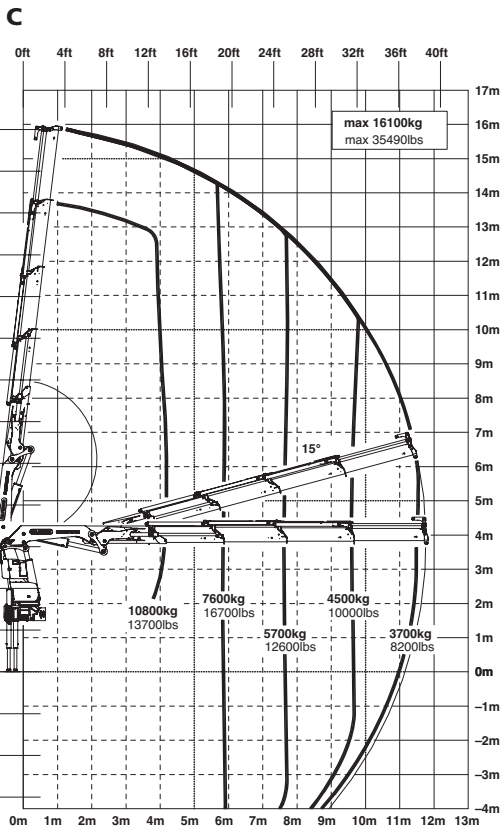

High payload combined with enormous outreach

A

Lifting capacities			
max.		16800 kg	37030 lbs
4.1 m	13' 5"	11300 kg	24900 lbs
5.8 m	19' 0"	8100 kg	17900 lbs
7.6 m	24' 11"	6200 kg	13700 lbs

B

Lifting capacities			
max.		16400 kg	36150 lbs
4.2 m	13' 9"	1100 kg	11000 lbs
5.8 m	19' 0"	7900 kg	7900 lbs
7.6 m	24' 11"	6000 kg	6000 lbs
9.6 m	31' 6"	4750 kg	4750 lbs

C

Lifting capacities			
max.		16100 kg	35490 lbs
4.2 m	13' 9"	10800 kg	13700 lbs
5.8 m	19' 0"	7600 kg	16700 lbs
7.6 m	24' 11"	5700 kg	12600 lbs
9.6 m	31' 6"	4500 kg	10000 lbs
11.6 m	38' 1"	3700 kg	8200 lbs

D

Lifting capacities			
max.		15300 kg	33700 lbs
4.3 m	14' 1"	10300 kg	22700 lbs
6.0 m	19' 8"	7300 kg	16000 lbs
7.8 m	25' 7"	5400 kg	12000 lbs
9.7 m	31' 10"	4250 kg	9400 lbs
11.7 m	38' 5"	3450 kg	7600 lbs
13.9 m	45' 7"	2900 kg	6400 lbs

E

Lifting capacities			
max.		14600 kg	32180 lbs
4.4 m	14' 5"	9900 kg	21900 lbs
6.1 m	20' 0"	7000 kg	15300 lbs
7.9 m	25' 11"	5200 kg	11400 lbs
9.8 m	32' 2"	4000 kg	8800 lbs
11.8 m	38' 9"	3250 kg	7100 lbs
14.0 m	45' 11"	2700 kg	5900 lbs
16.2 m	53' 2"	2300 kg	5100 lbs

F

Lifting capacities			
max.		14000 kg	30860 lbs
4.5 m	14' 9"	9600 kg	21100 lbs
6.2 m	20' 4"	6700 kg	14800 lbs
8.0 m	26' 3"	5000 kg	10900 lbs
9.9 m	32' 6"	3800 kg	8400 lbs
11.9 m	39' 1"	3050 kg	6700 lbs
14.1 m	46' 3"	2500 kg	5500 lbs
16.4 m	53' 10"	2100 kg	4600 lbs
18.6 m	61' 0"	1840 kg	4050 lbs

G

Lifting capacities			
max.		13800 kg	30400 lbs
4.5 m	14' 9"	9400 kg	20700 lbs
6.2 m	20' 4"	6500 kg	14400 lbs
8.0 m	26' 3"	4800 kg	10500 lbs
9.9 m	32' 6"	3650 kg	8000 lbs
12.0 m	39' 4"	2850 kg	6300 lbs
14.2 m	46' 7"	2300 kg	51000 lbs
16.4 m	53' 10"	1920 kg	4250 lbs
18.6 m	61' 0"	1660 kg	3650 lbs
20.8 m	68' 3"	1480 kg	3250 lbs
23.0 m*	75' 6"	900 kg	1980 lbs
25.0 m*	82' 0"	600 kg	1320 lbs

E PJ125E JV1 DPS PLUS

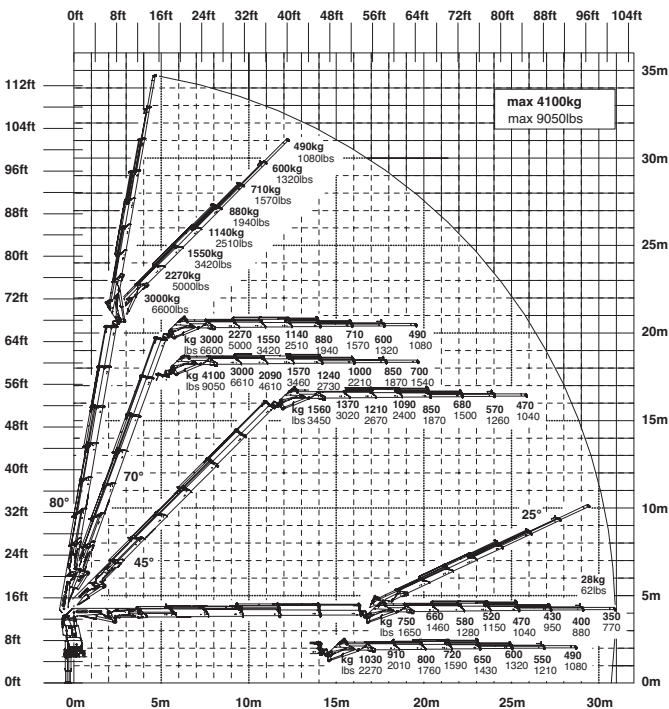

F PJ080C JV2 DPS PLUS

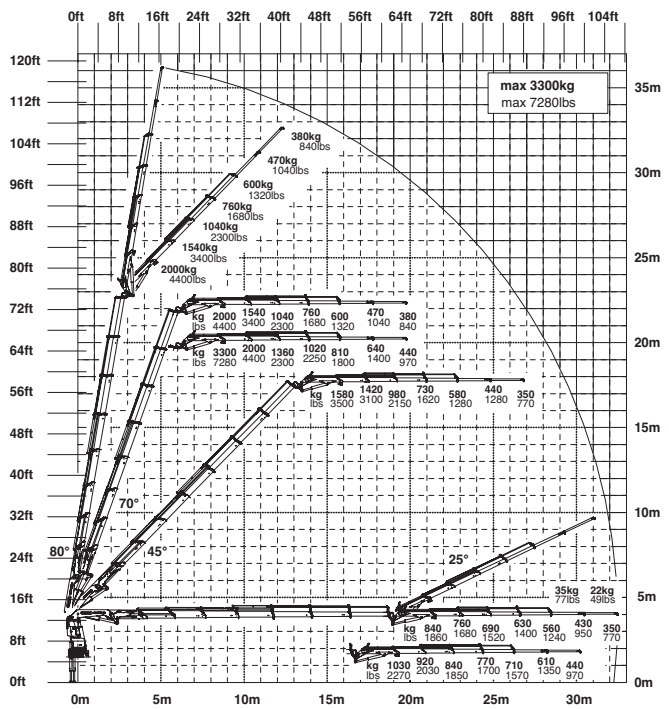

The outreaches stated are with a boom angle of 20° and are therefore not the maximum.

* mechanical extension

Low servicing and maintenance expense

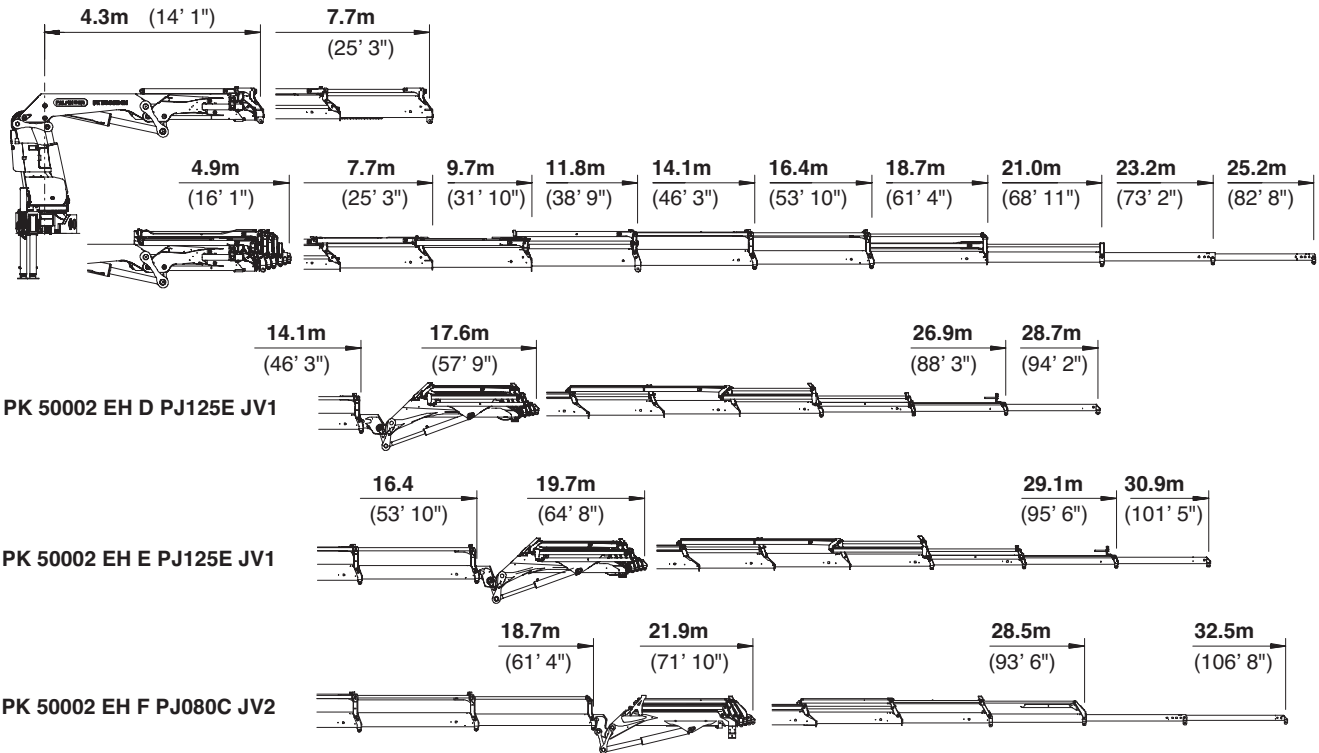

Technical Specifications (EN 12999 HC1 HD4/B3)

Max. lifting moment	48.0 mt/470.9 kNm	347320 ft.lbs
Max. lifting capacity	17100 kg/167.8 kN	37700 lbs
Max. hydraulic outreach	21.0 m	68' 11"
Max. manual outreach	25.2 m	82' 8"
Max. outreach (with fly jib)	32.5 m	106' 8"
Slewing angle	endless	
Slewing torque		
with 1 gear	4.0 mt/39.2 kNm	28910 ft.lbs
with 2 gears	5.5 mt/54.0 kNm	39830 ft.lbs

Stabilizer spread	7.8 m	25' 7"
Fitting space required (std.)	min. 1.33 m/4' 4"	max. 1.47 m/4' 10"
Width folded	2.51 m	8' 3"
Max. operating pressure	350 bar	5075 psi
Recommended pump capacity	from 80 l/min	21.1 US gal./min
	to 100 l/min	26.4 US gal./min
Dead weight (std.)	4145 kg	9140 lbs

