

LIFTING CHARTS - Rough Terrain Cranes

TADANO MODEL TR-650XL-3 - 65 TON CAPACITY

OPERATING RADIUS/LIFTING HEIGHT CHART

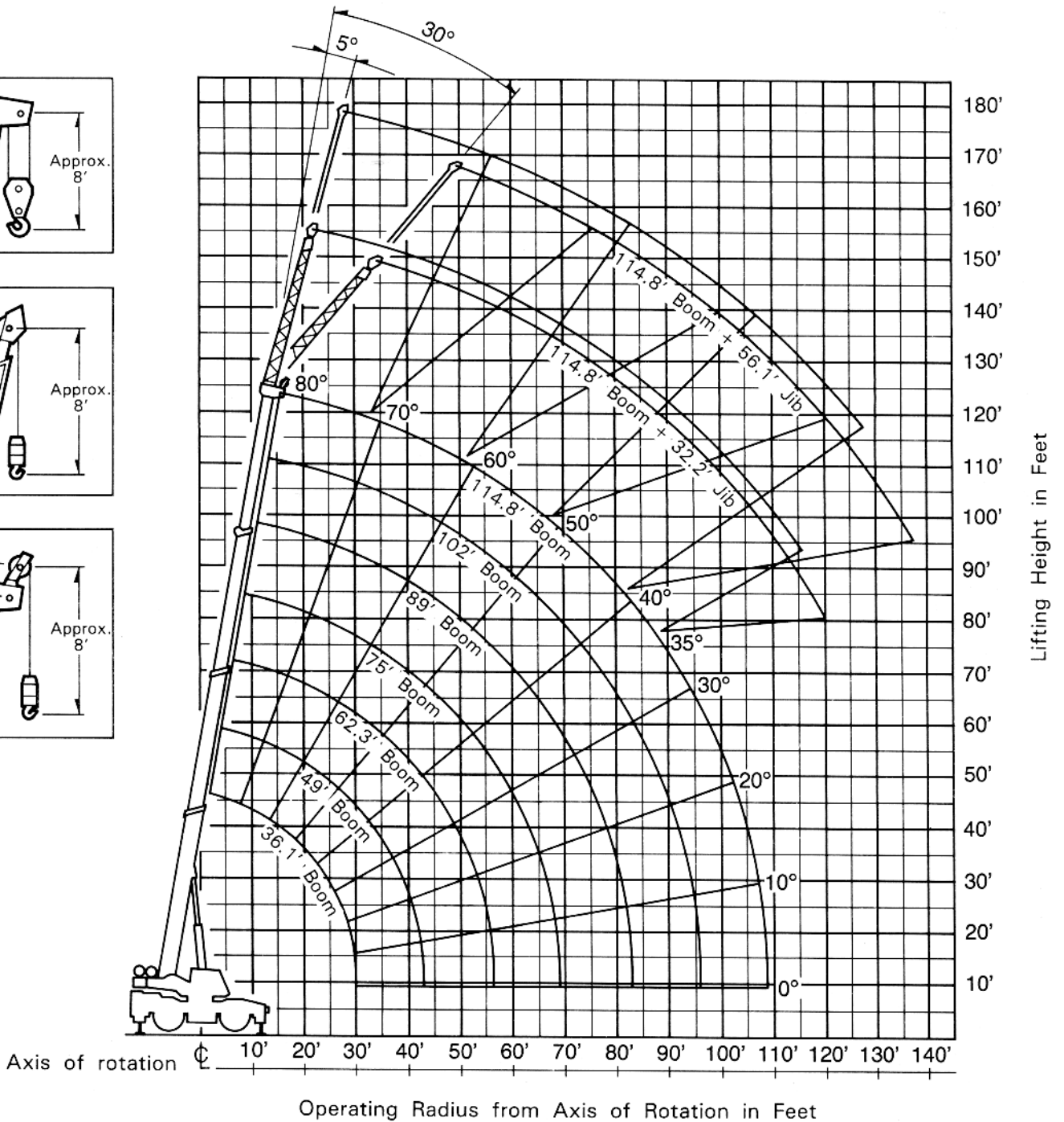
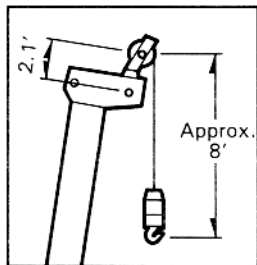
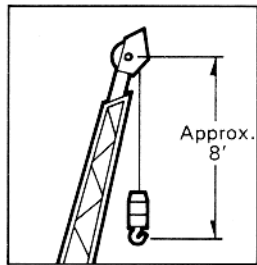
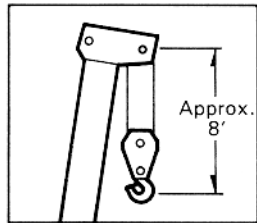

NOTE: Boom and jib geometry shown are for unloaded condition and machine standing level on firm supporting surface. Boom deflection and subsequent radius and boom angle change must be accounted for when applying load to hook.

TOTAL RATED LOAD CHART (IN POUNDS)

A → B	ON OUTRIGGERS FULLY EXTENDED 360° ROTATION							ON OUTRIGGERS MID. EXTENDED 21' 11-3/4" (6.7m) SPREAD 360° ROTATION						
	36.1' (11m)	49' (14.9m)	62.3' (19.0m)	75' (22.9m)	89' (27.1m)	102' (31.1m)	114.8' (35.0m)	36.1' (11m)	49' (14.94m)	62.3' (19.0m)	75' (22.9m)	89' (27.1m)	102' (31.1m)	114.8' (35.0m)
10'	130,000	91,000	82,000					130,000	91,000	82,000				
12'	113,800	91,000	82,000	47,400				113,800	91,000	82,000	47,400			
15'	95,200	91,000	72,000	47,400	47,400			95,200	91,000	72,000	47,400	47,400		
20'	73,300	72,800	63,000	47,400	43,600	34,700		73,300	72,800	63,000	47,400	43,600	34,700	
25'	58,600	58,100	55,100	43,600	38,100	31,400	28,800	49,400	49,200	51,400	43,600	38,100	31,400	28,800
30'	33,500	43,100	41,100	37,300	32,900	27,500	25,500	33,500	35,300	35,700	37,300	32,900	27,500	25,500
35'		32,400	32,400	32,400	28,500	24,500	22,400		26,600	26,300	27,400	28,500	24,500	22,400
40'		25,000	24,800	26,300	25,100	21,700	19,700		20,400	20,300	21,200	22,700	21,700	19,700
45'			19,400	20,900	21,500	19,400	17,500			16,100	17,000	18,300	19,100	17,500
50'			15,700	16,900	17,800	17,500	15,800			12,800	14,000	15,100	16,100	15,800
55'			12,500	13,900	14,800	15,900	14,300			10,100	11,600	12,600	13,200	13,000
60'				11,500	12,300	13,100	13,000				9,300	10,500	11,000	10,900
65'				9,500	10,400	11,100	11,300				7,600	8,600	9,200	9,300
70'					8,800	9,400	9,900					7,100	7,600	7,900
75'					7,400	8,100	8,500					5,700	6,400	6,900
80'					6,300	6,900	7,300					4,600	5,200	5,700
85'						5,900	6,300						4,400	4,800
90'						4,800	5,500						3,600	4,000
95'						4,100	4,800						2,900	3,300
100'							4,100							2,600
105'							3,200							2,100
108'							3,100							1,700
C				0°							0°			

A : Boom length in feet B : Operating radius in feet C : Minimum boom angle (deg.) for indicated length (no load)

A → B	ON OUTRIGGERS MID. EXTENDED 18' 1/2" (5.5m) SPREAD 360° ROTATION						
	36.1' (11m)	49' (14.94m)	62.3' (19.0m)	75' (22.9m)	89' (27.1m)	102' (31.1m)	114.8' (35.0m)
10'	130,000	91,000	82,000				
12'	113,800	91,000	82,000	47,400			
15'	95,200	91,000	72,000	47,400	47,400		
20'	60,300	60,300	59,500	47,400	43,600	34,700	
25'	39,700	39,700	38,300	38,200	38,100	31,400	28,800
30'	27,800	27,400	27,200	28,800	29,800	27,500	25,500
35'		20,400	20,000	21,100	22,500	23,100	22,400
40'		15,500	15,100	16,100	17,500	18,000	18,600
45'			11,300	12,500	14,000	14,300	15,000
50'			8,600	9,900	11,100	11,500	12,200
55'			6,500	7,900	8,900	9,400	10,000
60'				6,200	7,100	7,700	8,200
65'				4,800	5,700	6,200	6,700
70'					4,400	4,900	5,400
75'					3,400	4,000	4,300
80'					2,500	3,000	3,500
85'						2,300	2,800
90'						1,600	2,100
95'							1,600
100'							
105'							
108'							
C			0°			12°	28°

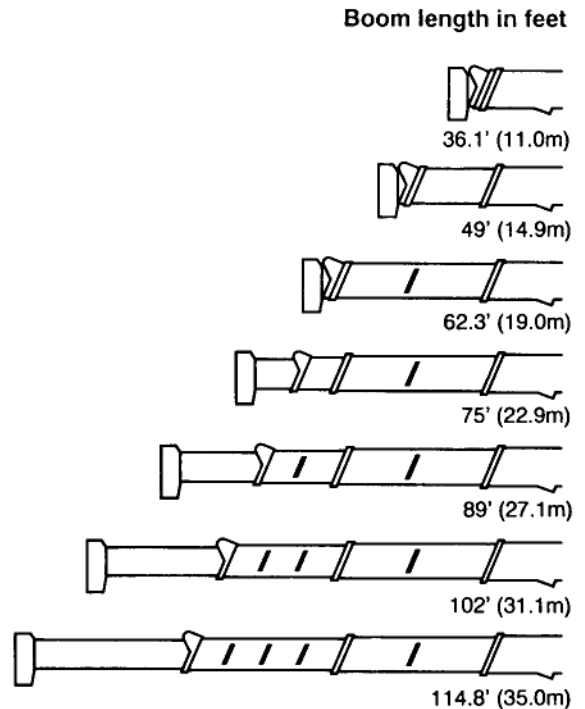

TOTAL RATED LOAD CHART (IN POUNDS)

Boom Angle in Degree	ON OUTRIGGERS FULLY EXTENDED 360° ROTATION								ON OUTRIGGERS MID. EXTENDED 21' 11-3/4" (6.7m) SPREAD 360° ROTATION							
	Boom Length in Feet								Boom Length in Feet							
	114.8' (35.0m) Boom + 32.2' (9.8m) Jib				114.8' (35.0m) Boom + 56.1' (17.1m) Jib				114.8' (35.0m) Boom + 32.2' (9.8m) Jib				114.8' (35.0m) Boom + 56.1' (17.1m) Jib			
	5° offset		30° offset		5° offset		30° offset		5° offset		30° offset		5° offset		30° offset	
R	W	R	W	R	W	R	W	R	W	R	W	R	W	R	W	
80°	26.3	12,300	38.2	6,100	33.8	6,100	54.7	2,400	26.3	12,300	38.0	6,100	33.8	6,100	54.7	2,400
75°	40.0	11,000	50.9	5,500	49.5	5,000	69.5	2,200	40.0	11,000	50.9	5,500	49.5	5,000	69.5	2,200
70°	52.7	8,800	63.4	5,000	64.6	4,100	83.4	1,900	52.7	8,800	63.4	5,000	64.6	4,100	83.4	1,900
65°	64.4	7,000	74.7	4,700	78.6	3,500	96.1	1,800	64.4	7,000	74.7	4,700	78.6	3,500	96.1	1,800
60°	75.9	5,700	85.4	4,400	92.3	3,000	108.0	1,700	75.9	5,700	85.4	4,400	92.3	3,000	108.0	1,700
55°	86.5	4,700	95.1	3,800	105.0	2,600	119.0	1,600	86.5	4,700	95.1	3,800	105.0	2,600	119.0	1,600
50°	96.3	3,800	104.0	3,300	116.0	2,300	129.0	1,500	96.1	3,200	104.0	2,800	116.0	2,300	129.0	1,500
45°	105.0	3,200	112.0	2,900	127.0	2,000	137.0	1,400	105.0	2,100	111.0	1,800	126.0	1,600	137.0	1,100
40°	113.0	2,400	119.0	2,200	136.0	1,700	147.0	1,300	113.0	1,200	118.0	1,100				
35°	121.0	1,700	125.0	1,600												

R : Operating radius in feet **W** : Total rated load in pounds

Boom Angle in Degree	ON OUTRIGGERS MID. EXTENDED 18' 1/2" (5.5m) SPREAD 360° ROTATION							
	Boom Length in Feet							
	114.8' (35.0m) Boom + 32.2' (9.8m) Jib				114.8' (35.0m) Boom + 56.1' (17.1m) Jib			
	5° offset		30° offset		5° offset		30° offset	
R	W	R	W	R	W	R	W	
80°	26.3	12,300	38.2	6,100	33.8	6,100	54.7	2,400
75°	40.0	11,000	50.9	5,500	49.5	5,000	69.5	2,200
70°	52.7	8,800	63.4	5,000	64.6	4,100	83.4	1,900
65°	64.4	7,000	74.7	4,700	78.6	3,500	96.1	1,800
60°	75.5	4,600	85.2	3,800	92.3	3,000	108.0	1,700
55°	85.6	2,700	94.4	2,200	104.0	1,900	119.0	1,400
50°	95.3	1,400	103.0	1,100				
45°								
40°								
35°								

NOTE: Operating radiuses for jib operation are given for reference with the boom fully extended to 114.8' (35.0m).

6,200lbs. (2,800kg) shall be subtracted from the rated lifting capacities of main boom, when jib is attached to main boom head.

Jib weight is 2,200lbs. (1,000kg).

Standard number of parts of line should be according to the following table.

Boom Length in Feet (meters)	36.1' (11.0)	36.1' to 62.3' (11.0 to 19.0)	62.3' to 114.8' (19.0 to 35.0)	Single top Jib
No. of parts of line	11	8	4	1

The lifting capacity data stored in the LOAD MOMENT INDICATOR (AML-L) is based on the standard number of parts of line listed in the chart.

RATED LIFTING CAPACITIES (IN POUNDS)

ON RUBBER									
A→ B	Stationary						Creep		
	Over Front			360° Rotation			Over Front		
	Boom Length in Feet			Boom Length in Feet			Boom Length in Feet		
	36.1' (11.0m)	62.3' (19.0m)	89' (27.1m)	36.1' (11.0m)	62.3' (19.0m)	89' (27.1m)	36.1' (11.0m)	62.3' (19.0m)	89' (27.1m)
10'	67,200			34,300			50,000		
12'	58,600			32,700			45,600		
15'	51,300	34,100		24,800	22,900		39,600	30,500	
20'	36,000	30,000	20,700	15,400	14,900	15,600	30,600	26,500	18,300
25'	25,200	24,000	20,700	9,900	9,500	10,500	23,700	22,800	18,300
30'	18,100	17,200	17,600	6,000	5,900	7,000	18,100	17,200	16,300
35'		12,500	13,600		3,400	4,500		12,500	13,600
40'		9,200	10,800		1,600	2,900		9,200	10,800
45'		6,800	8,500			1,500		6,800	8,500
50'		4,900	6,900					4,900	6,900
55'		3,400	5,300					3,400	5,300
60'			4,000						4,000
65'			2,900						2,900
70'			2,100						2,100
75'			1,500						1,500
C		0°	20°	0°	43°	55°		0°	20°

A: Boom length in feet (meters)

B: Operating radius in feet

C: Minimum boom angle (deg.) for indicated length (no load)

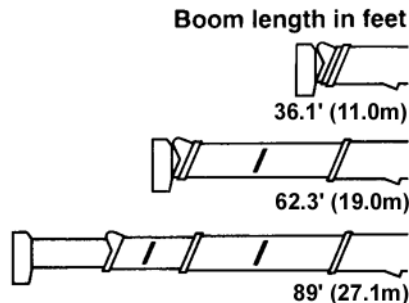
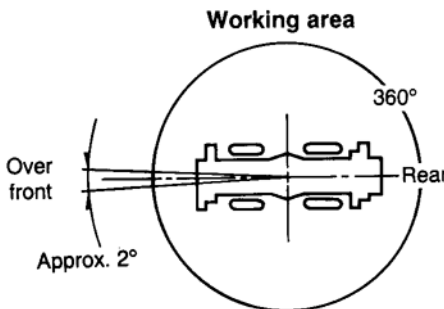

NOTE : Standard number of parts of line for on rubber operation should be according to the following table.

The lifting capacity data stored in the LOAD MOMENT INDICATOR (AML-L) is based on the standard number of parts of line listed in the chart.

Boom Length in Feet (meters)	36.1' (11.0)	36.1' to 89' (11.0 to 27.1)	Single top
No. of parts of line	6	4	1

WARNING AND OPERATING INSTRUCTIONS FOR ON RUBBER CAPACITIES

- Total rated loads on rubber are in pounds and do not exceed 75% of tipping loads as determined by SAE J765-Crane Stability Test Code.
- Total rated loads shown in the chart are based on condition that crane is set on firm level surfaces with axle oscillation lockout applied. Those above bold lines are based on tire capacity and those below, on crane stability. They are based on actual load radius increased by tire deformation and boom deflection.
- If the axle oscillation lockout cylinders contain air, the axle will not be locked completely and total rated loads may not be obtainable. Bleed the cylinders according to the operation, safety and maintenance manual.
- Total rated loads are based on proper tire inflation, capacity and condition. Damaged tires are hazardous to safe operation of crane.
- Tires shall be inflated to correct air pressure.
- Over front operation shall be performed within two degrees in front of chassis.
- On rubber lifting with "jib" is not permitted. Maximum permissible boom length is 89ft. (27.1 m).
- When making lift on rubber (stationary), set parking brake.
- For creep operation, boom must be centered over front of machine, swing lock engaged, and load restrained from swinging. Travel slowly and keep the lifted load as close to the ground as possible, and especially avoid any abrupt steering, accelerating or braking.
- Do not operate the crane while carrying the load.
- Creep is motion for crane not to travel more than 200ft. (60m) in any 30 minute period and to travel at the speed of less than 1 mph (1.6km/h).
- For creep operation, set drive select switch to "4-WHEEL (Lo)" and set gear shift lever to "1".

Tires	Air Pressure
29.5-25-22PR	60 psi. (4.2kgf/cm ²)

WARNING AND OPERATING INSTRUCTIONS FOR LIFTING CAPACITIES

GENERAL

1. Total rated loads on the TOTAL RATED LOAD CHART apply only to the machine as originally manufactured and normally equipped by TADANO LTD. Modifications to the machine or use of optional equipment other than that specified can result in a reduction of capacity.
2. Construction equipment can be hazardous if improperly operated or maintained. Operation and maintenance of this machine must be in compliance with the information in the operation, safety and maintenance manual supplied with machine. If this manual is missing, order replacement through the distributor.
3. The operator and other personnel associated with this machine shall fully acquaint themselves with the latest American National Standards Institute (ANSI) safety standards for cranes.

SET UP

1. Total rated loads on the chart are the maximum allowable crane capacities and are based on the machine standing level on firm supporting surface under ideal job conditions. Depending on the nature of the supporting surface, it may be necessary to have structural supports under the outrigger floats or tires to spread the load to a larger bearing surface.
2. For outrigger operation, outriggers shall be properly extended with tires free of supporting surface before operating crane.

OPERATION

1. Total rated loads have been tested to and meet minimum requirements of SAE J1063-Cantilevered Boom Crane Structures - Method of Test.
2. Total rated loads do not exceed 85% of the tipping loads on outriggers fully extended as determined by SAE J765Crane Stability Test Code. Total rated loads for partially extended outriggers are determined from the formula, Total Rated Load = (Tipping Load-0.1 x Tip Reaction) / 1.25.
3. Total rated loads above bold lines in the chart are based on crane strength and those below, on its stability. They are based on actual load radius increased by boom deflection.
4. Total rated loads include the weight of main hook block (1,100lbs. for 65 ton capacity), auxiliary hook ball (330lbs. for 6.2 ton capacity), sling and auxiliary lifting devices and their weights shall be subtracted from the listed capacities to obtain the net load to be lifted.
5. Total rated loads are based on freely suspended loads and make no allowance for such factors as the effect of wind, sudden stopping of loads, supporting surface conditions, inflation of tires, operating speeds, side loads, etc. Side pull on boom or jib is extremely dangerous.
6. Total rated loads do not account for wind on lifted load or boom. Total rated loads and boom length shall be appropriately reduced, when wind velocity is above 20mph (9m/sec.).
7. Total rated loads at load radius shall not be exceeded. Do not tip the crane to determine allowable loads.
8. Do not operate at boom lengths, radii, or boom angle, where no capacities are shown. Crane may overturn without any load on the hook.

9. When boom length is between values listed, refer to the total rated loads of the next longer and next shorter booms for the same radius. The lesser of the two total rated loads shall be used.
10. When making lifts at a load radius not shown, use the next longer radius to determine allowable capacity.
11. Load per line should not exceed 11,900lbs. (5,400kg) for main winch and 12,300lbs. (5,600kg) for auxiliary winch.
12. The boom angle before loading should be greater to account for deflection.
13. The 36.1' (11.0m) boom length capacities are based on boom fully retracted. If not fully retracted [less than 49' (14.9m) boom length], use the total rated loads for the 49' (14.9m) boom length.
14. Extension or retraction of the boom with loads may be attempted within the limits of the TOTAL RATED LOAD CHART. The ability to telescope loads is limited by hydraulic pressure, boom angle, boom length, crane maintenance, etc.
15. For lifting capacity of single top, reduce the total rated loads of relevant boom by 1,000lbs. (450kg). Capacities of single top shall not exceed 12,300lbs. (5,600kg) including main hook.
16. When erecting and stowing jib, be sure to retain it by hand or by other means to prevent its free movement.
17. 6,200lbs. (2,800kg) shall be subtracted from the total rated loads of the main boom, when jib is attached to main boom head. Jib weight is 2,200lbs. (1,000kg).
18. Use Anti-two block (OVERWIND CUTOUT) disable switch when erecting and stowing the jib and stowing the hook block. While the switch is pushed, the hoist does not stop, even when overwind condition occurs.
19. For boom lengths with 32.2' (9.8m) jib, the total rated loads are determined by loaded boom angle only in the column headed 114.8' (35.0m) boom + 32.2' (9.8m) jib. For boom lengths with 56.1' (17.1m) jib, the total rated loads are determined by loaded boom angle only in the column headed 114.8' (35.0m) boom + 56.1' (17.1m) jib. For angles not shown, use the next lower loaded boom angle to determine allowable capacity.
20. When lifting a load by using jib (aux. winch) and boom (main winch) simultaneously, do the following:
 - Enter the operation status as jib operation, not as boom operation.
 - Before starting operation, make sure that weight of load is within total rated load for jib.

DEFINITIONS

1. Load Radius: Horizontal distance from a projection of the axis of rotation to supporting surface before loading to the center of the vertical hoist line or tackle with load applied.
2. Loaded Boom Angle: The angle between the boom base section and the horizontal, after lifting the total rated load at the load radius.
3. Working Area: Area measured in a circular arc about the centerline of rotation.
4. Freely Suspended Load: Load hanging free with no direct external force applied except by the hoist line.
5. Side Load: Horizontal side force applied to the lifted load either on the ground or in the air.

WARNING AND OPERATING INSTRUCTIONS FOR USING THE LOAD MOMENT INDICATOR (AML-L)

1. When operating crane on outriggers:

- Set P.T.O. switch to "ON".
- Press the outrigger mode select key to register for the outrigger operation. The outrigger mode indicative symbol changes from flickering to lighting.
- Press the boom mode select key to register the boom mode. Each time the boom mode select key is pressed, the mode changes. Select the status that corresponds to the actual state of the boom.
- When erecting and stowing jib, select the status of jib set (jib state indicative symbol flicker).

2. When operating crane on rubber:

- Set P.T.O. switch to "ON".
- Press the on-tire mode select key. The outrigger mode indicative symbol will disappear as the on-tire mode indicative symbol comes on. Each time the on-tire mode select key is pressed, the mode changes. Select the creep operation, the on-tire mode indicative symbol flicker.
- Press the boom mode select key to register the boom mode.

However, pay attention to the following:

(1) For stationary operation:

- The front capacities are attainable only when the over front position symbol comes on. When the boom is more than 2 degrees from centered over front of chassis, 360° capacities are in effect.

- When a load is lifted in the front position and then swung to the side area, make sure the value of the LOAD MOMENT INDICATOR (AML-L) is below the 360° lifting capacity.

(2) For creep operation:

- The creep capacities are attainable only when boom is in the straight forward position of chassis and the over front position symbol is on. If boom is not in the straight forward position of chassis, never lift load.
3. A swing does not automatically stop even if the crane becomes overloaded.
 4. During crane operation, make sure that the displays on front panel are in accordance with actual operating conditions.
 5. The displayed values of LOAD MOMENT INDICATOR (AML-L) are based on freely suspended loads and make no allowance for such factors as the effect of wind, sudden stopping of loads, supporting surface conditions, inflation of tires, operating speed, side loads, etc. For safe operation, it is recommended when extending and lowering boom or swinging, lifting loads shall be appropriately reduced.
 6. LOAD MOMENT INDICATOR (AML-L) is intended as an aid to the operator. Under no condition should it be relied upon to replace use of capacity charts and operating instructions. Sole reliance upon LOAD MOMENT INDICATOR (AML-L) aids in place of good operating practice can cause an accident. The operator must exercise caution to assure safety.

HOISTING SPECIFICATIONS

LINE SPEEDS AND PULLS

Layer	Speed	Main or auxiliary hoist – 15 3/4" (0.4) drum					
		Line Speeds (2)		Line pulls			
		F.P.M	m/min	Available (1)		Permissible (4)	
				Lbs.	kgf	Lbs.	kgf
1st	Low	180	55	15,698	7,121	14,272	6,474
	High	361	110				
2nd	Low	197	60	14,647	6,644	13,315	6,040
	High	394	120				
3rd	Low	213	65	13,520	6,133	12,292	5,576
	High	427	130				
4th	Low	230	70	12,557	5,696	11,417	5,179
	High	460	140				
5th	Low	246	75	11,721	5,317	10,657	4,834
	High	492	150				
6th (3)	Low	262	80	10,989	4,985	9,991	4,532
	High	525	160				

- (1) Developed by machinery with first layer of wire rope, but not based on rope strength or other limitation in machinery or equipment.
- (2) Line speeds based only on hook block, not loaded.
- (3) Sixth layer of wire rope is not recommended for hoisting operations.
- (4) Permissible line pull may be affected by wire rope strength.

DRUM WIRE ROPE CAPACITIES

Wire Rope Layer	Main and auxiliary drum grooved lagging			
	3/4" (19 mm) wire rope			
	Rope per layer		Total wire rope	
	Feet	Meters	Feet	Meters
1	123.0	37.5	123.0	37.5
2	134.2	40.9	257.2	78.4
3	145.3	44.3	402.5	122.7
4	156.6	47.7	559.0	170.4
5	167.7	51.1	726.7	221.5
6	178.8	54.5	905.5	276.0

DRUM DIMENSIONS

	Inch	mm
Root Diameter	15-3/4"	400
Length	22-3/4"	578
Flange Diameter	25-3/8"	645

DIMENSIONS

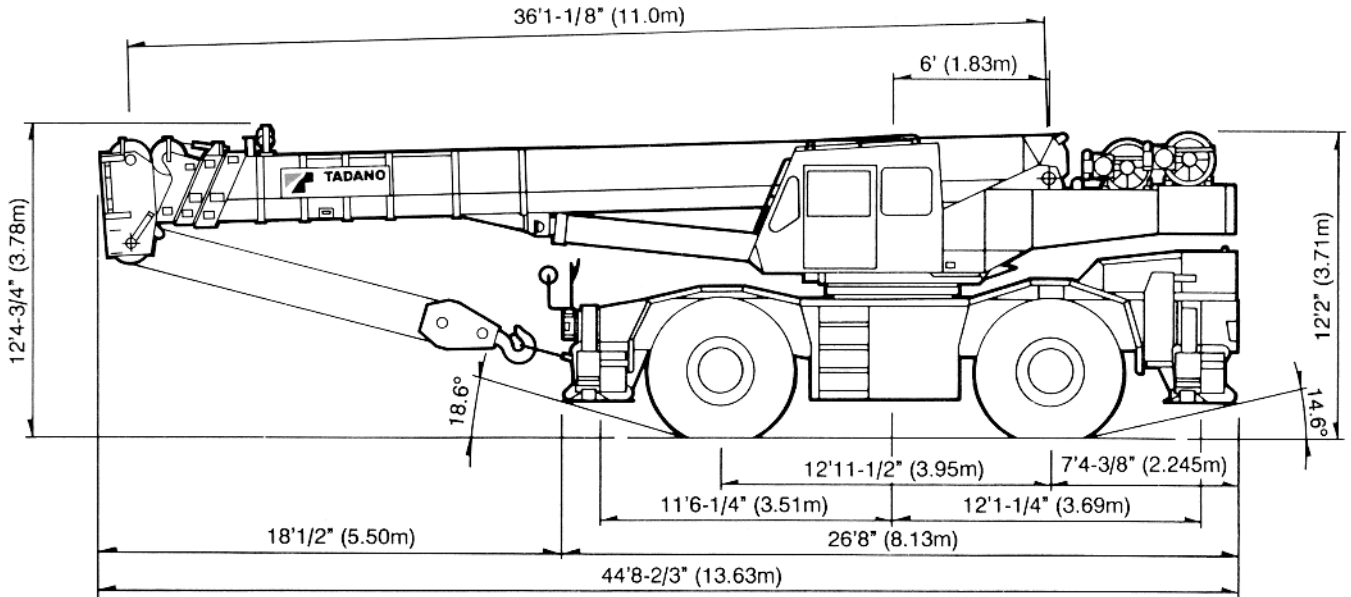

Note: Dimension is with boom angle at -1.5° .

GENERAL DIMENSIONS (29.5 X 25 Tires)

	Feet	Meters
Turning Radius:		
4 wheel steer	21' 11-3/4"	6.7
2 wheel steer	39' 1/2"	11.9
Tail swing of counterweight	13' 6-1/4"	4.12

