

03			
03 / 0100			
03 / 0200			
03 / 0300			
03 / 0400			
03 / 0500			
03 / 0600			
03 / 0700			
03 / 0800			
03 / 0900			
03 / 1000			
03 / 1100			
03 / 1200			
03 / 1300			
04			
04 / 0100			
04 / 0200			
04 / 0300			
04 / 0400			
04 / 0500			
04 / 0600			
04 / 0700			
04 / 0800			
04 / 0900			
04 / 1000			
04 / 1100			
04 / 1200			
04 / 1300			
04 / 1400			
04 / 1500			
04 / 1600			
04 / 1700			
04 / 1800			
04 / 1900			
04 / 2000			
04 / 2100			
04 / 2200			
04 / 2300			
04 / 2400			
04 / 2500			
05			
05 / 0100			

PALFINGER

PK36002JI

06			
06 / 0100			
06 / 0200			
06 / 0300			
06 / 0400			
06 / 0401			
06 / 0500			
06 / 0600			
06 / 0601			
06 / 0700			
06 / 0701			
06 / 0800			
06 / 0900			
06 / 1000			
08			
08 / 0100			
08 / 0200			
08 / 0300			
08 / 0400			
08 / 0500			
08 / 0600			
08 / 0700			
08 / 0800			
08 / 0900			
08 / 0901			

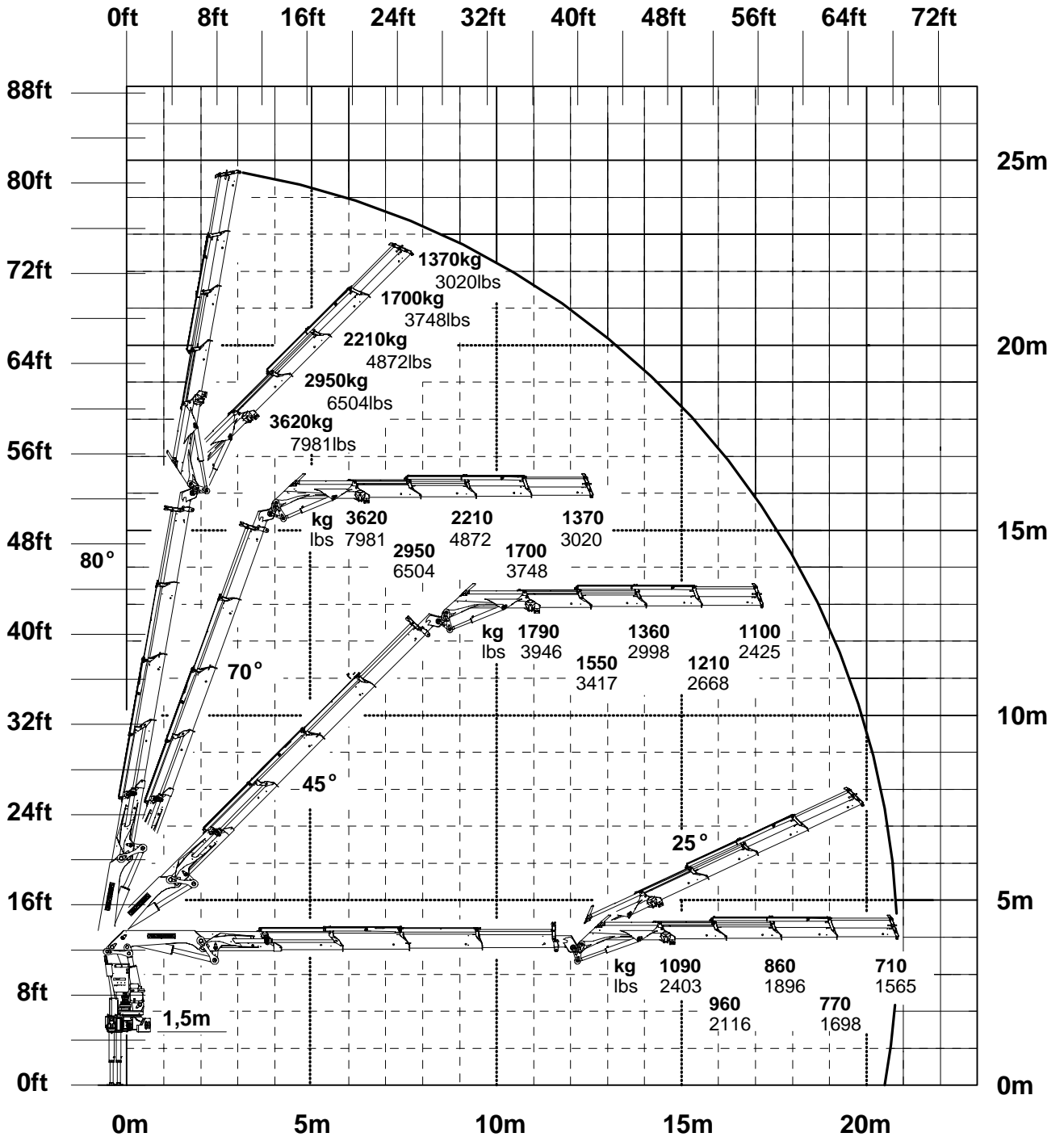

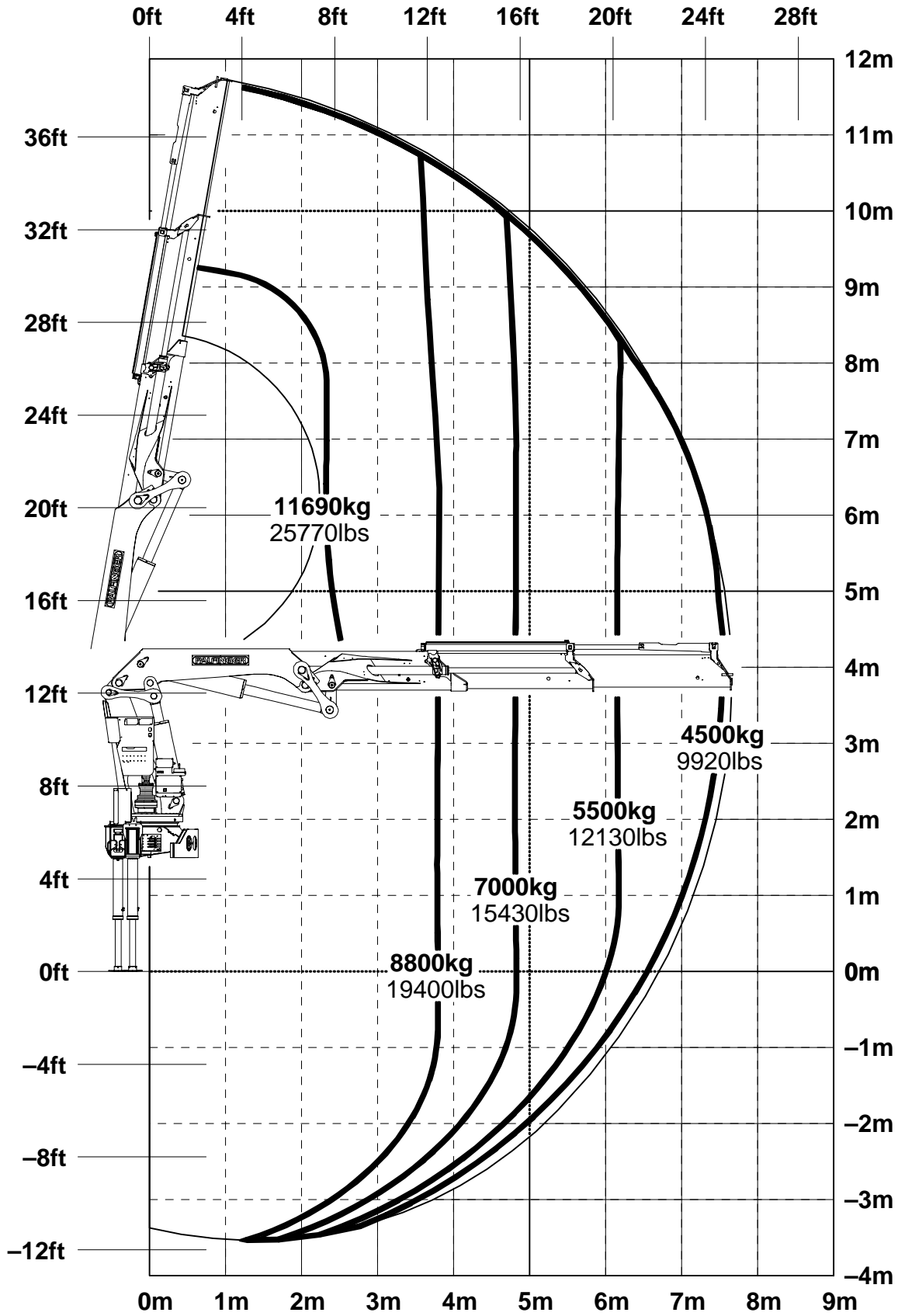

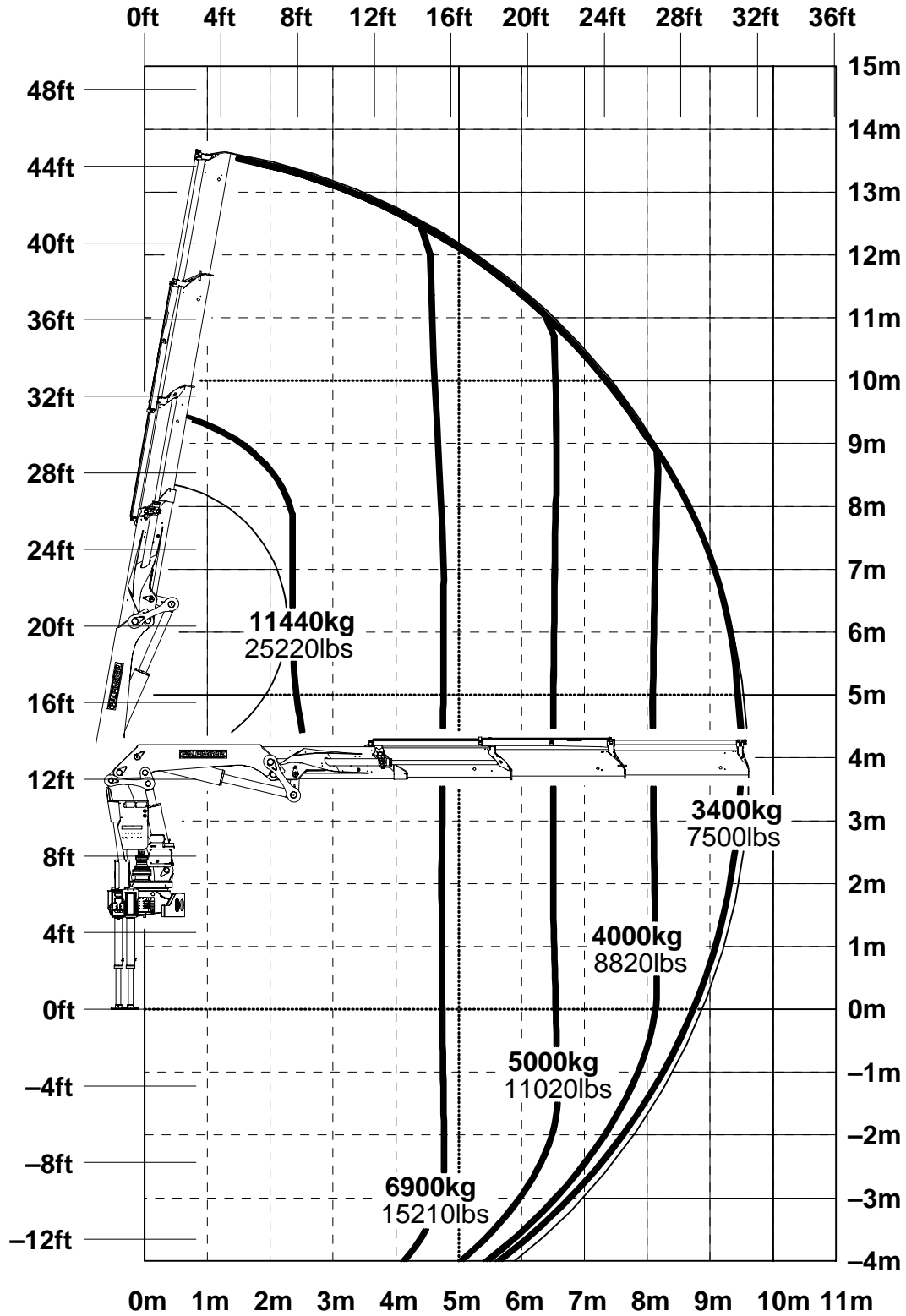

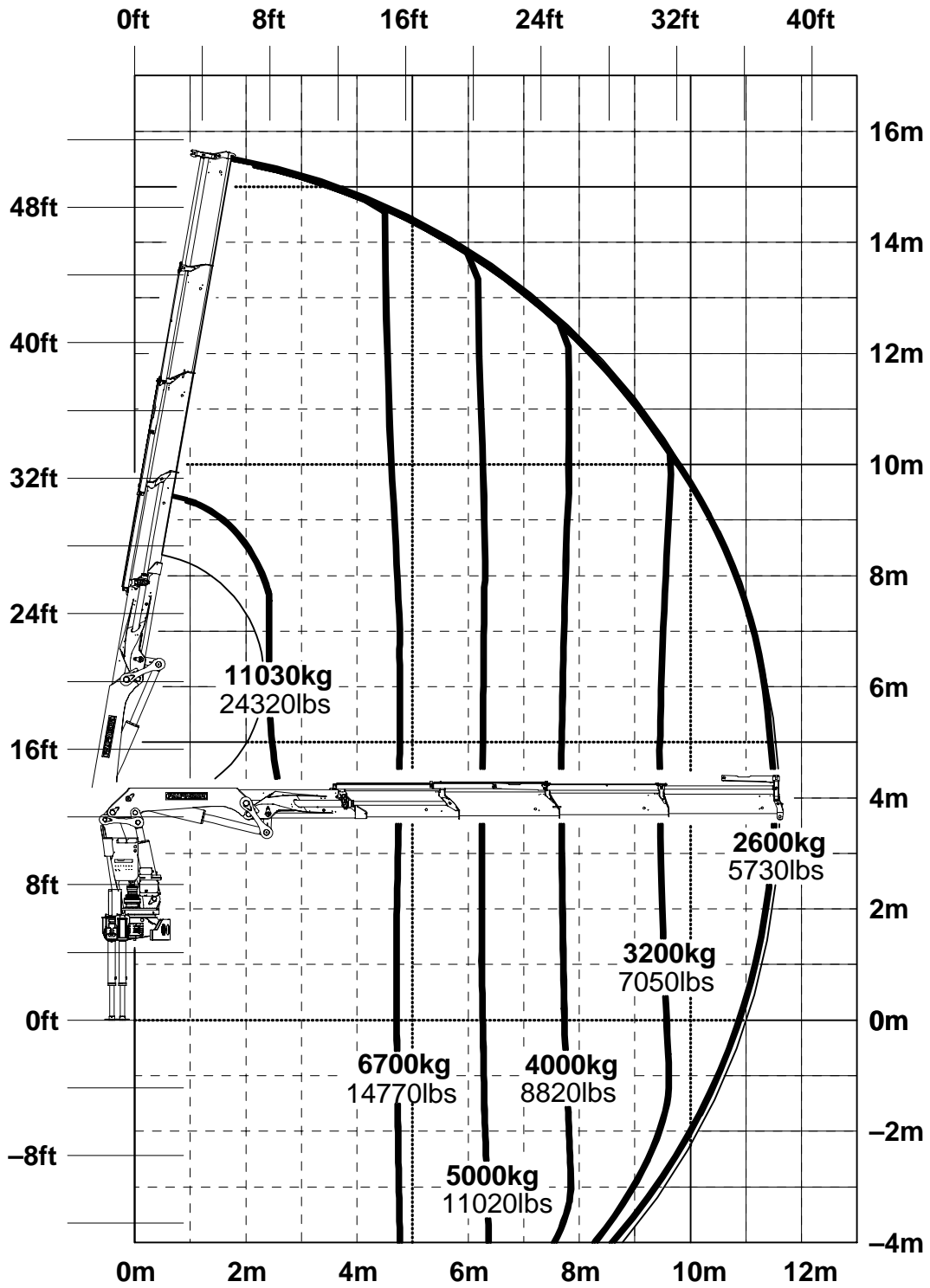

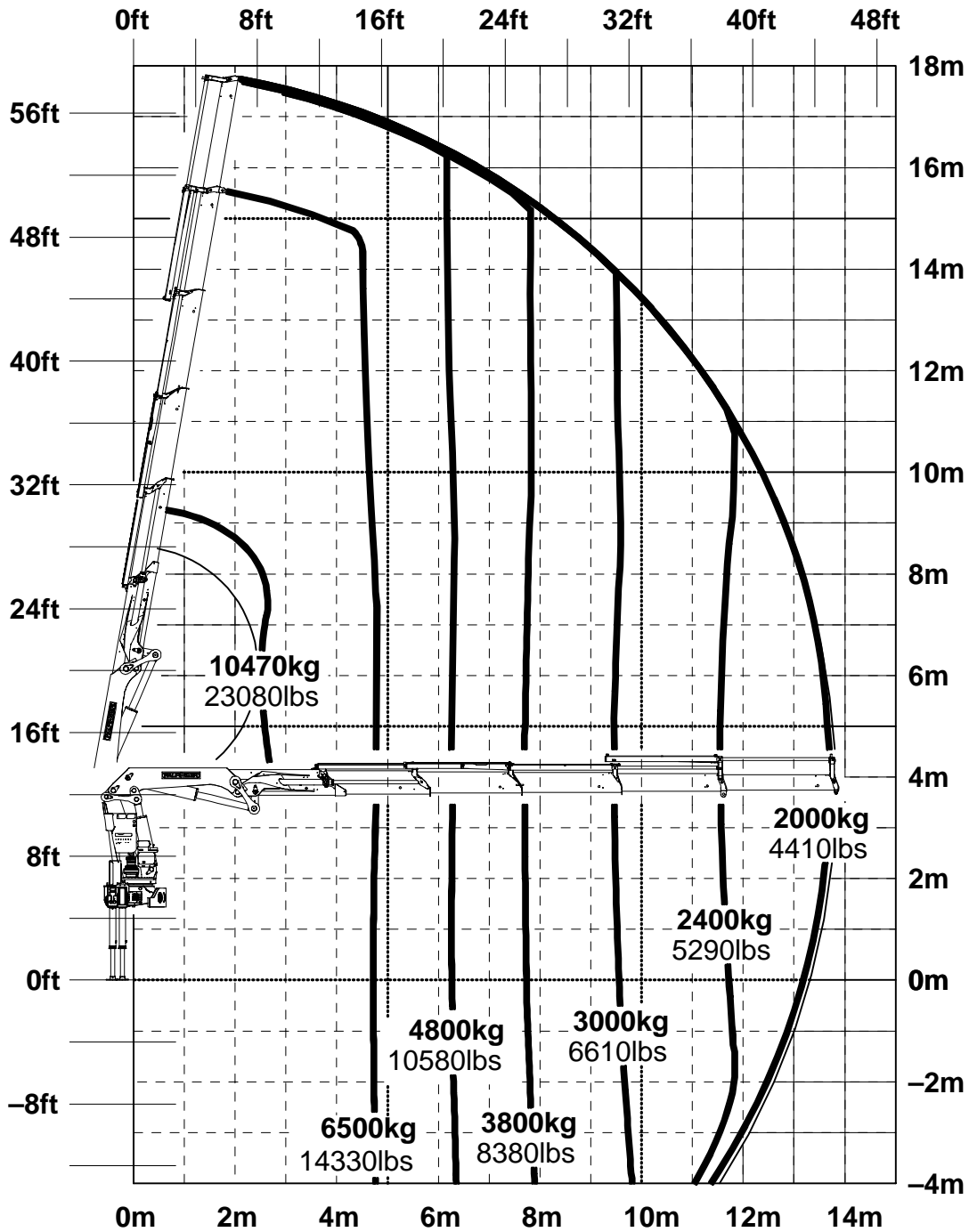

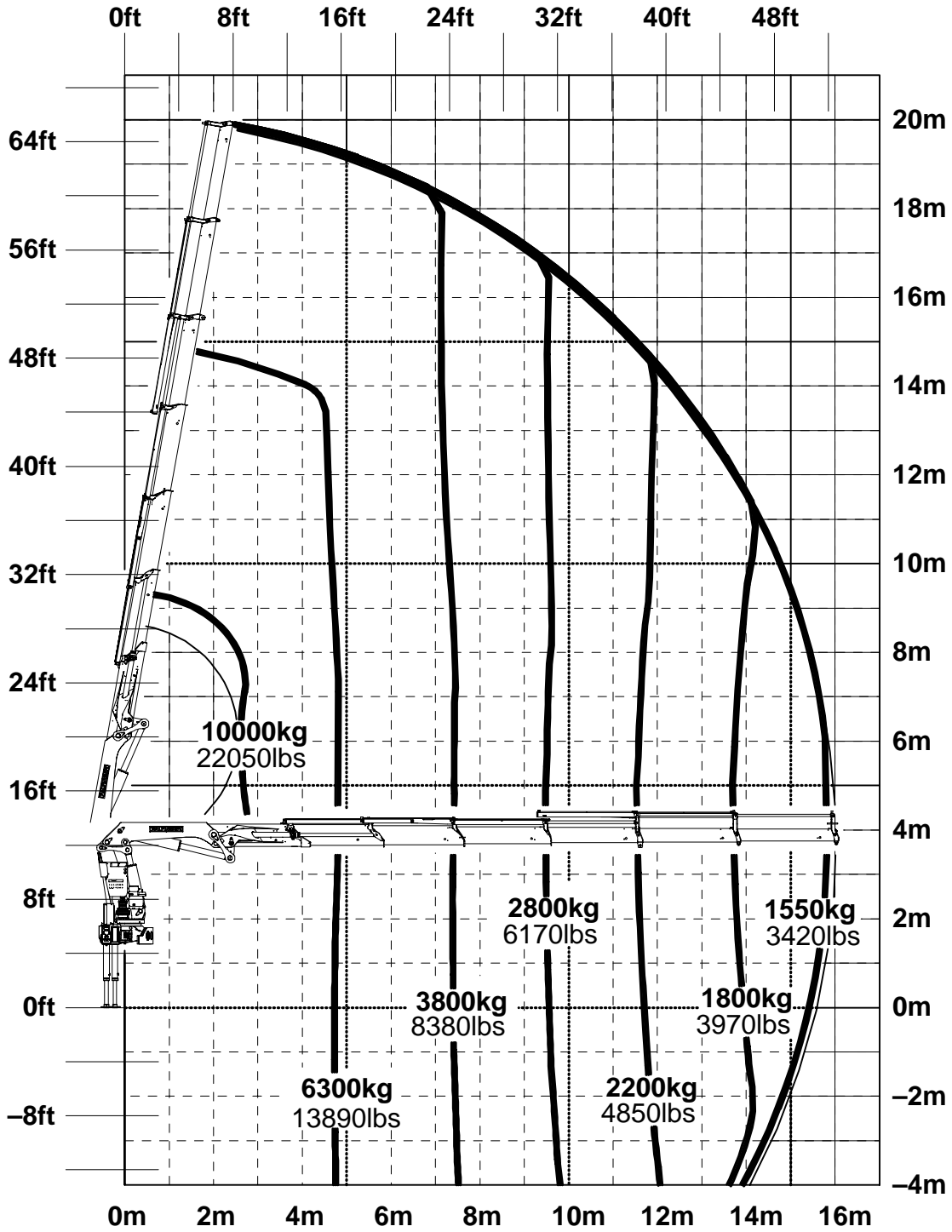

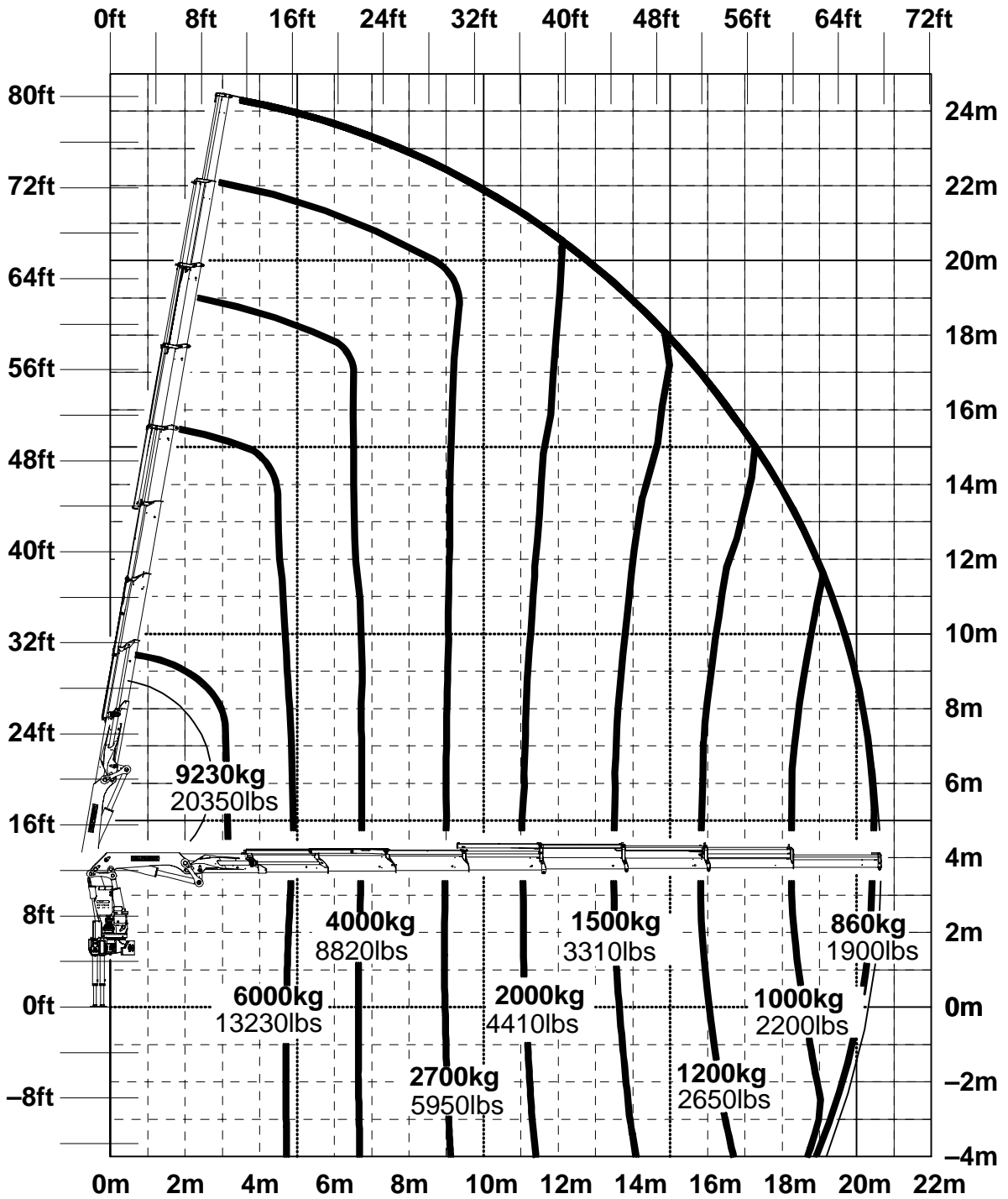

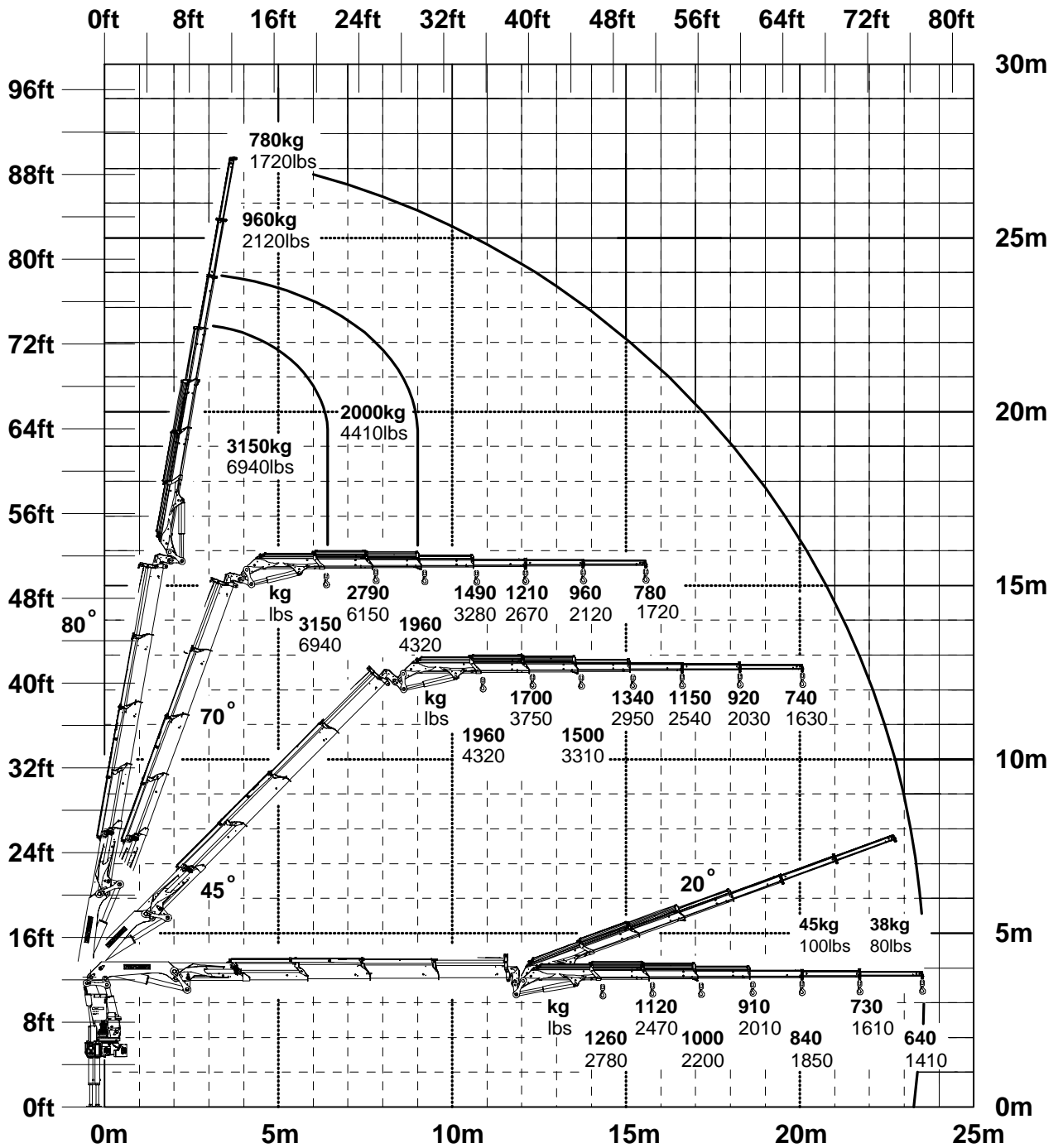

Modell Model Type
PK 36002
 PK 36002C PJ115D

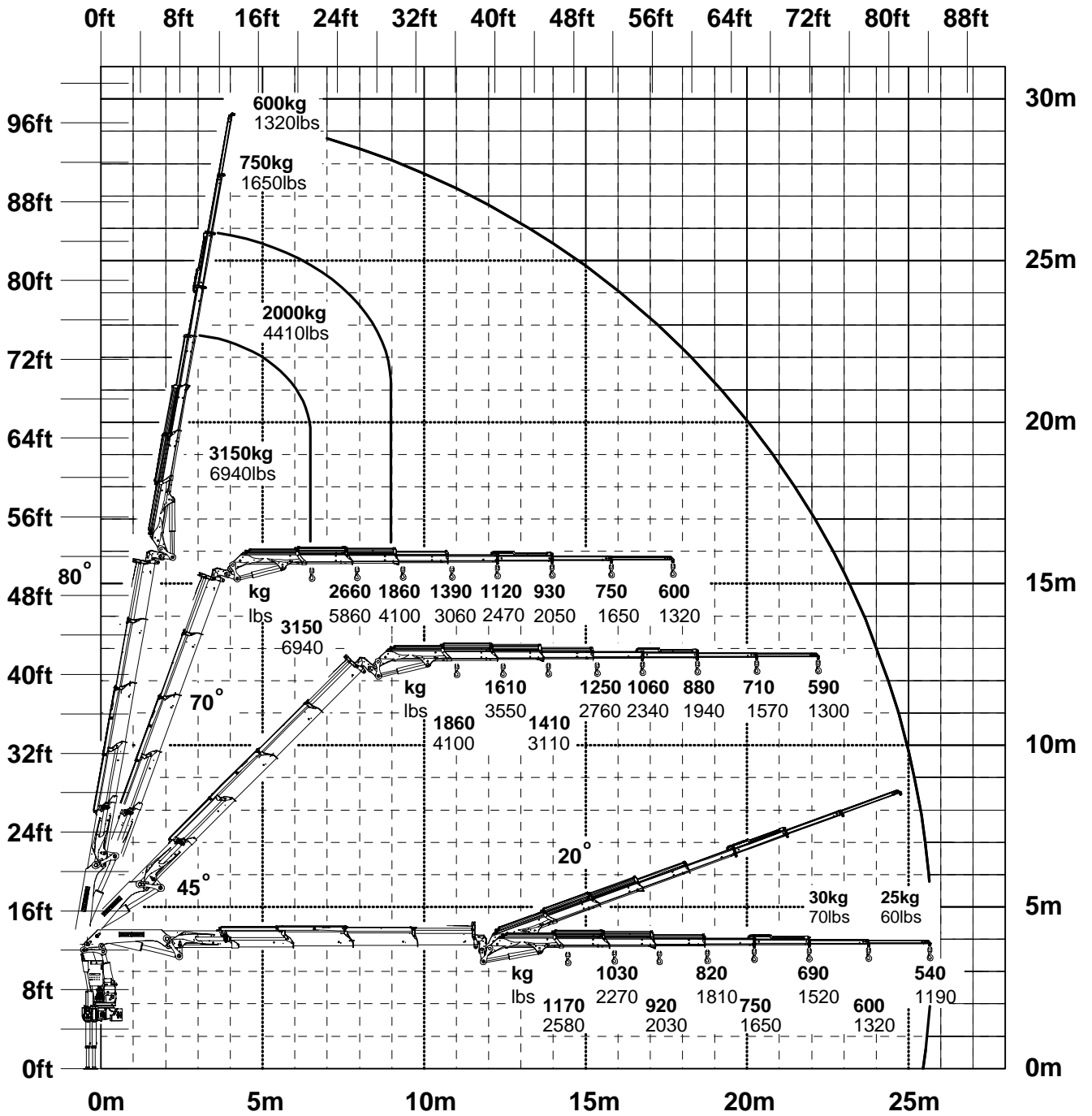

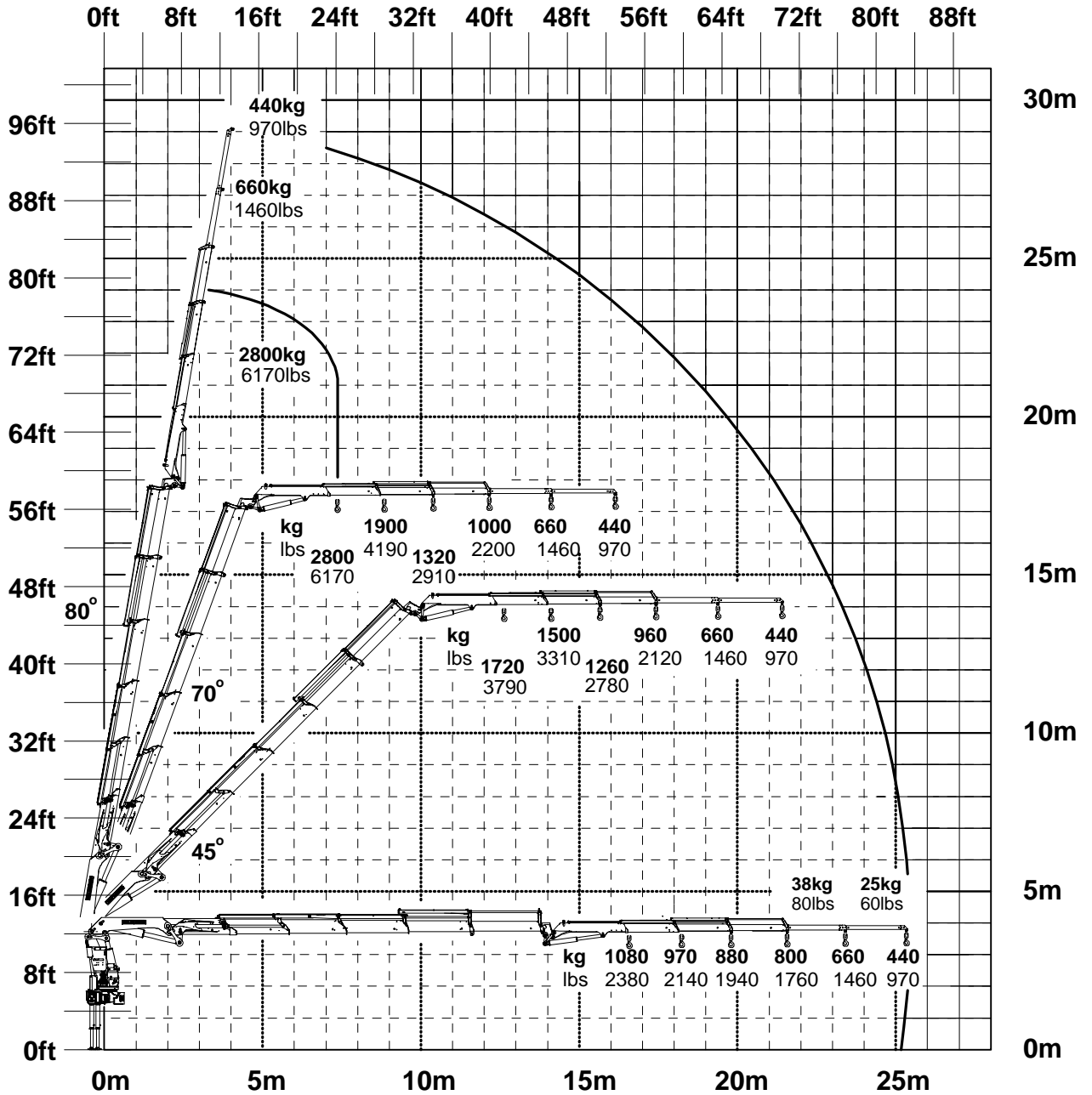

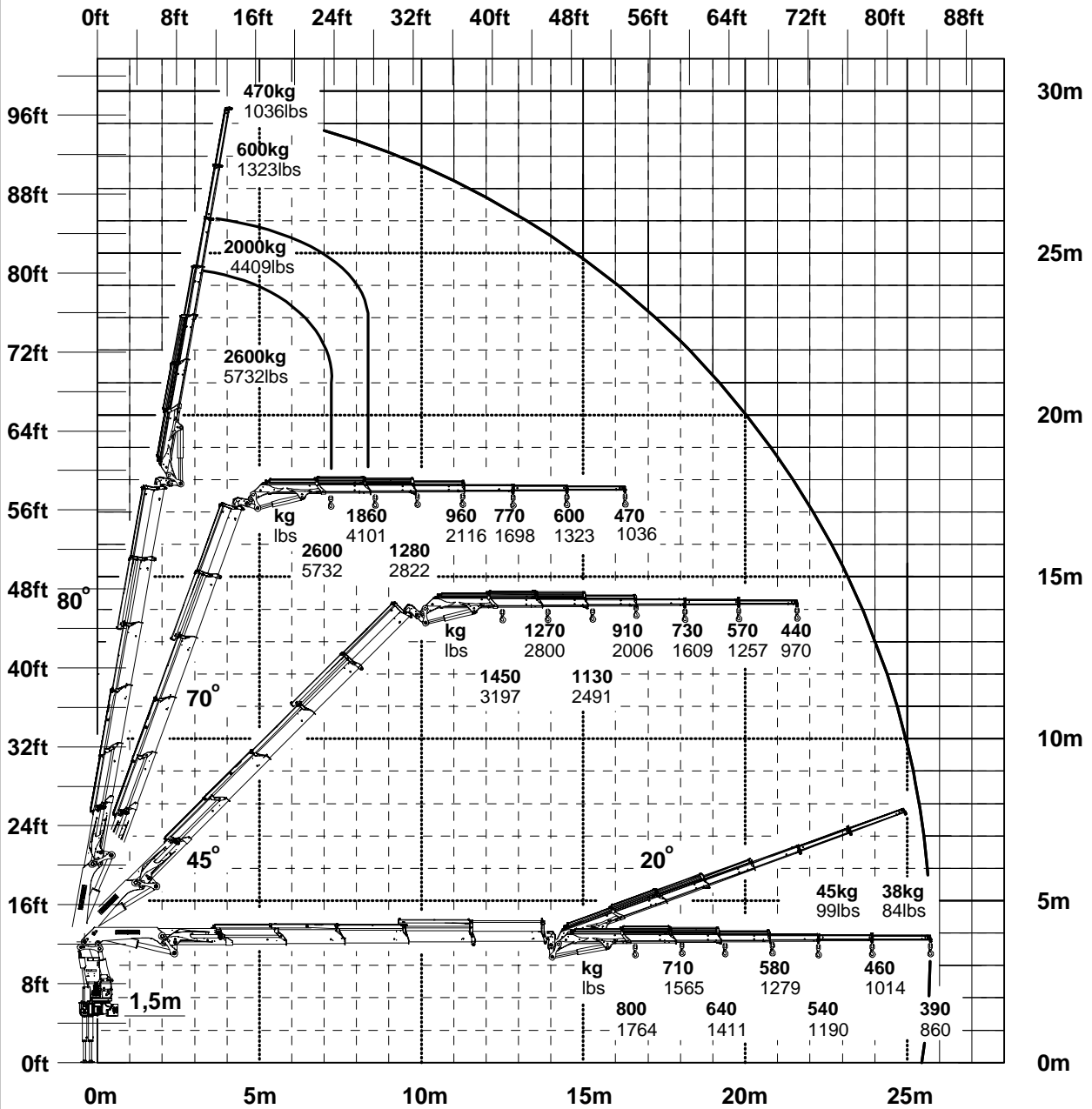

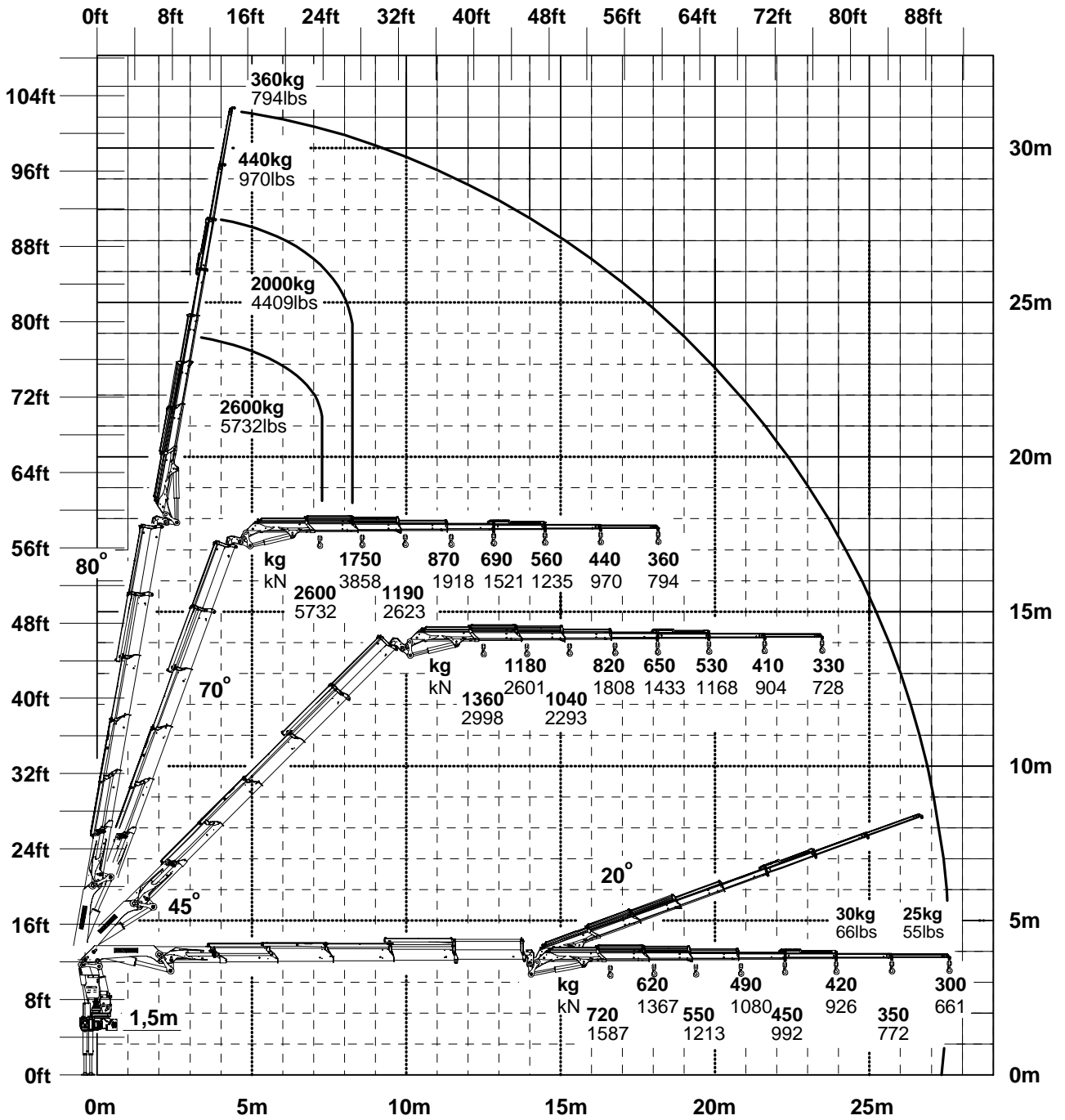

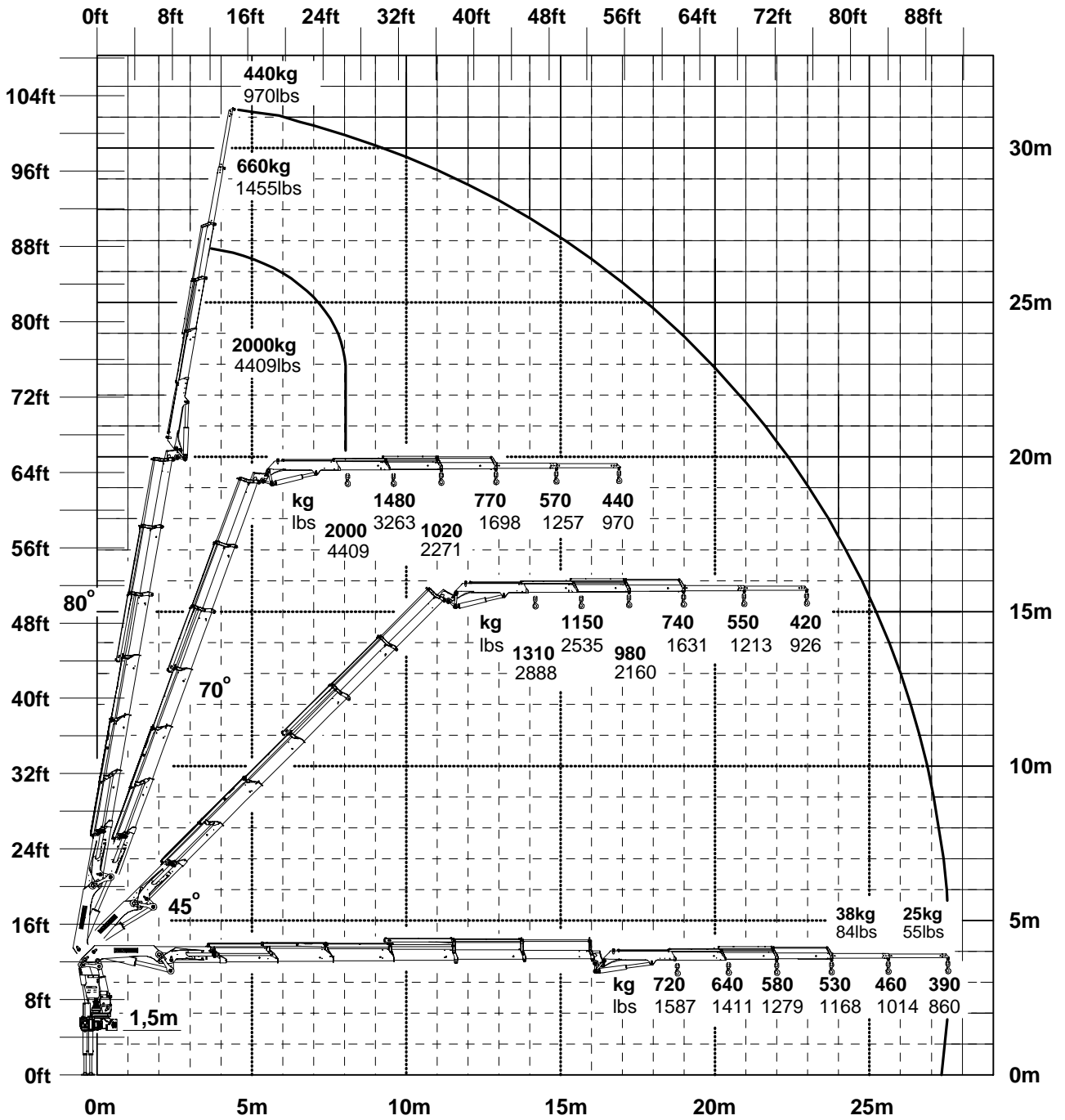

PK 36002 V1E



PK 36002 V2E



PK 36002 V1G

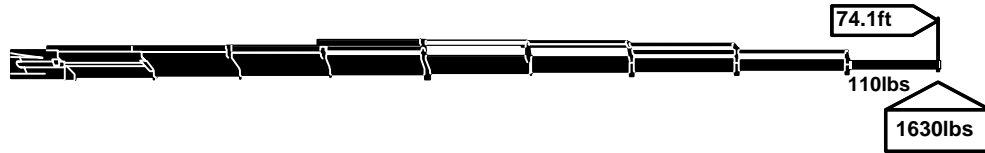

PK 36002 V2G

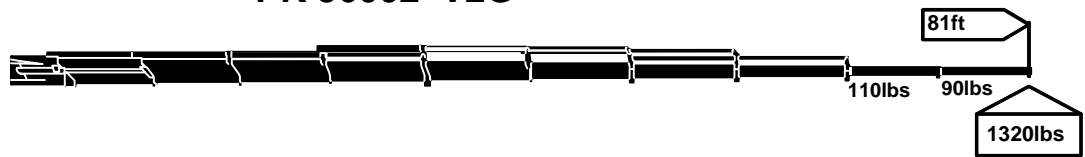

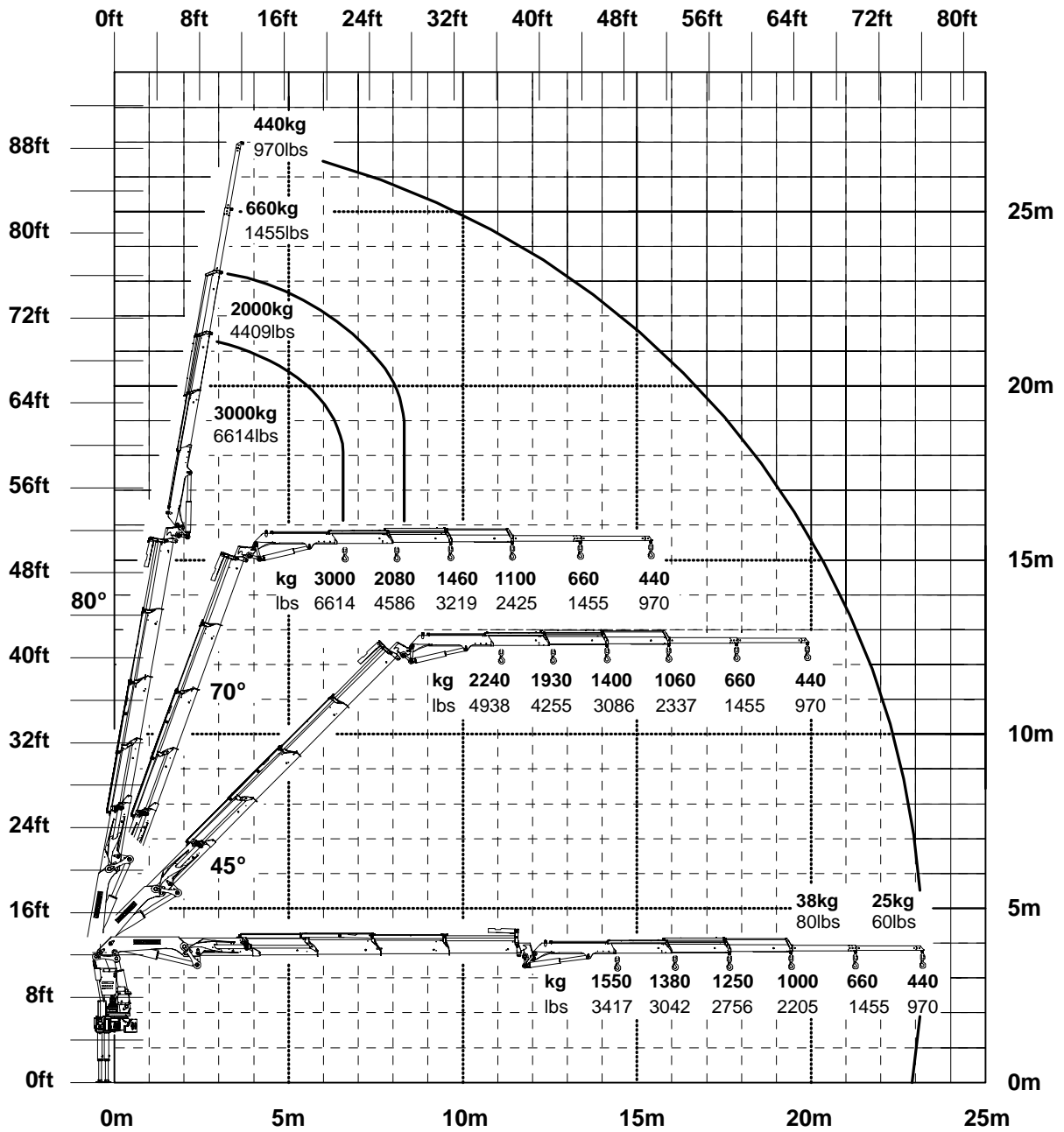

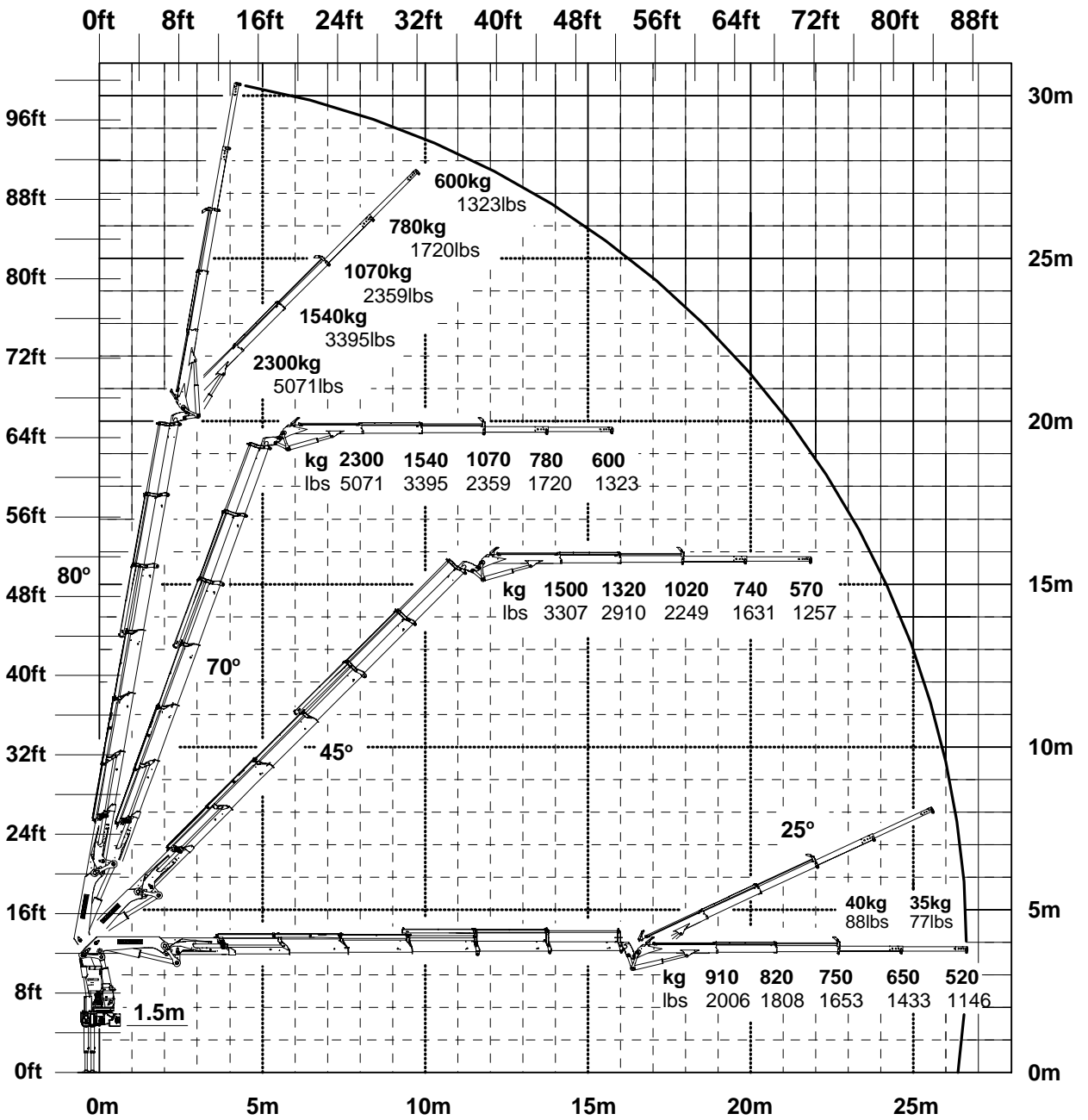

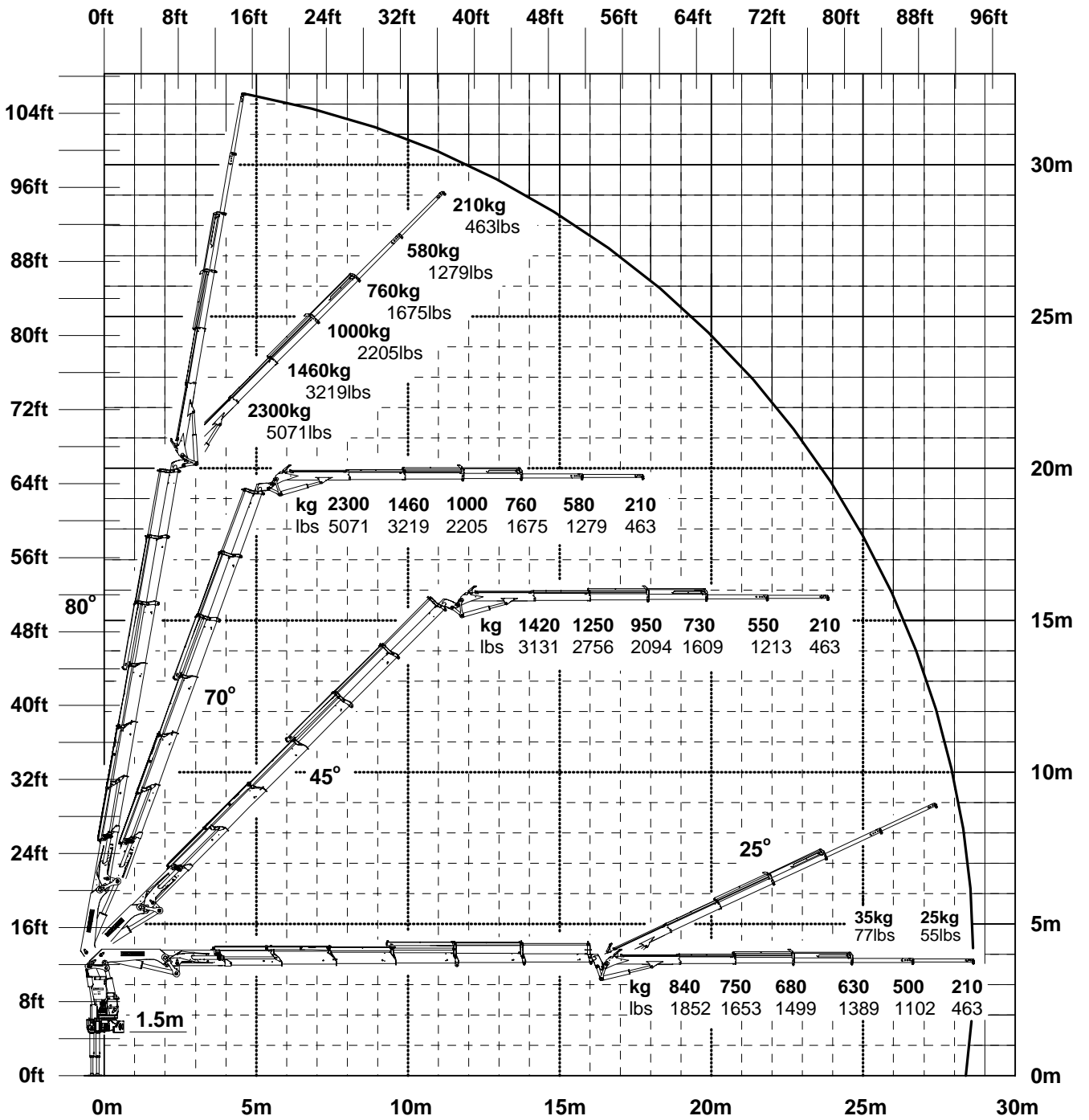

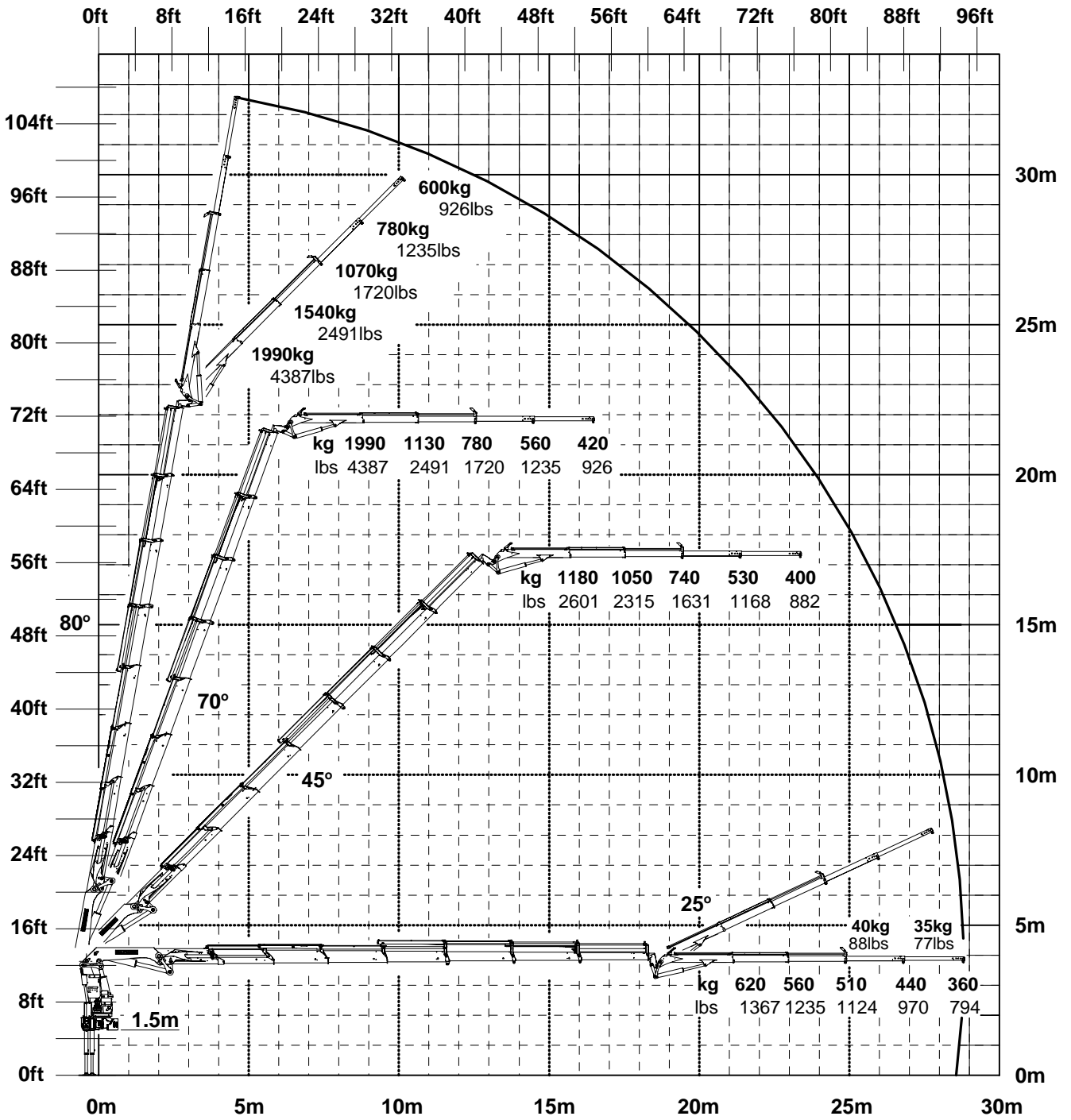

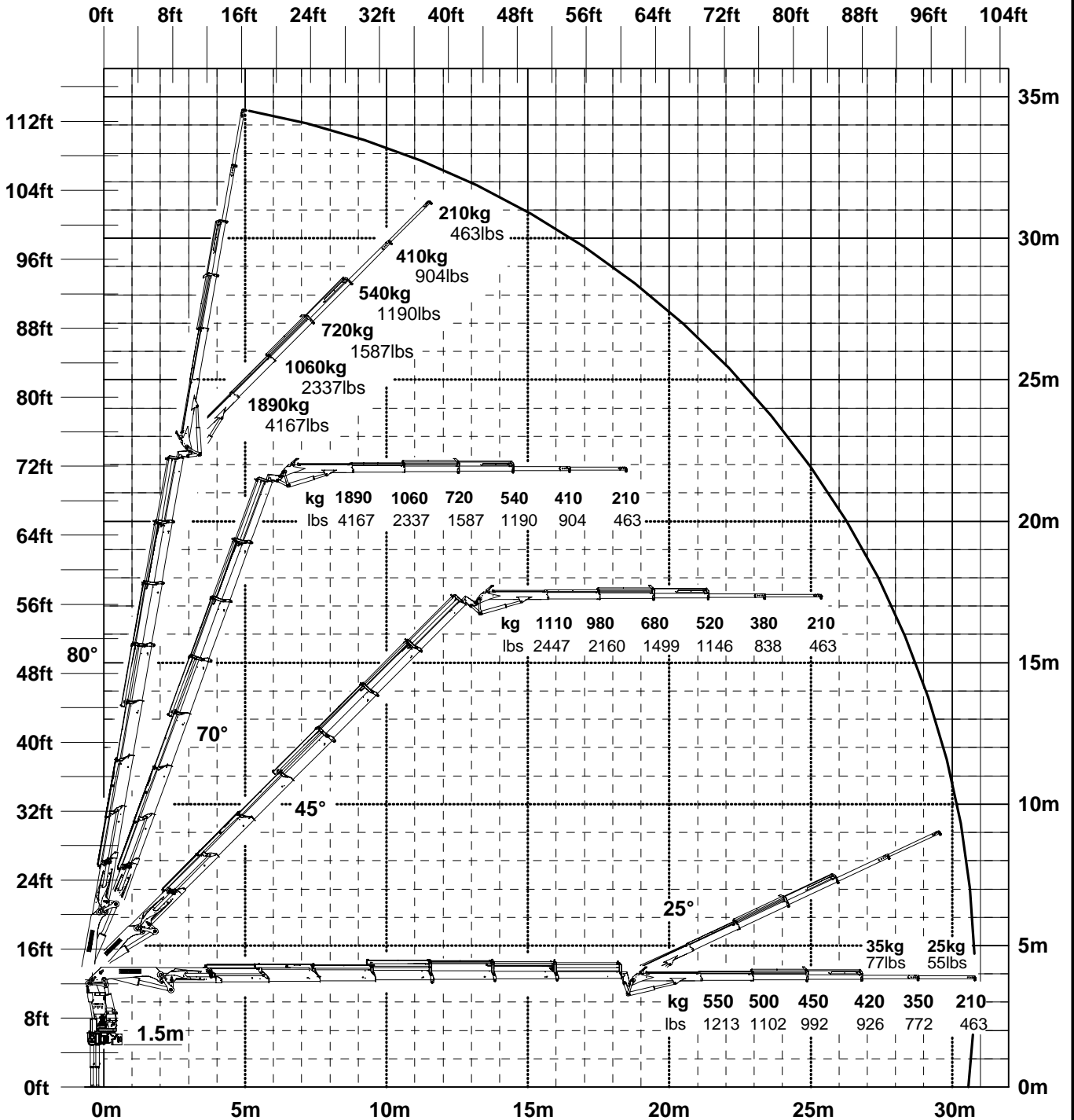

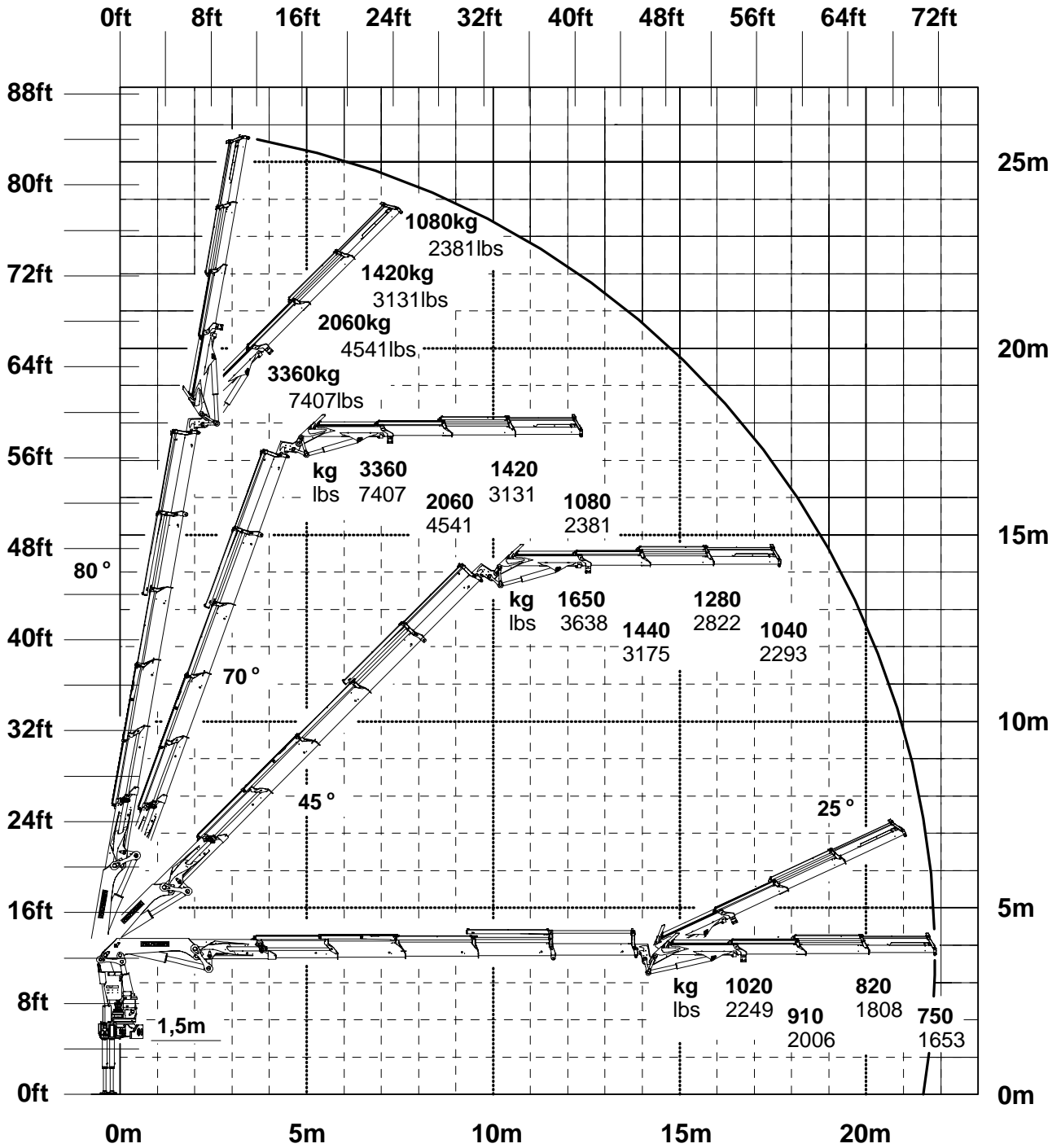

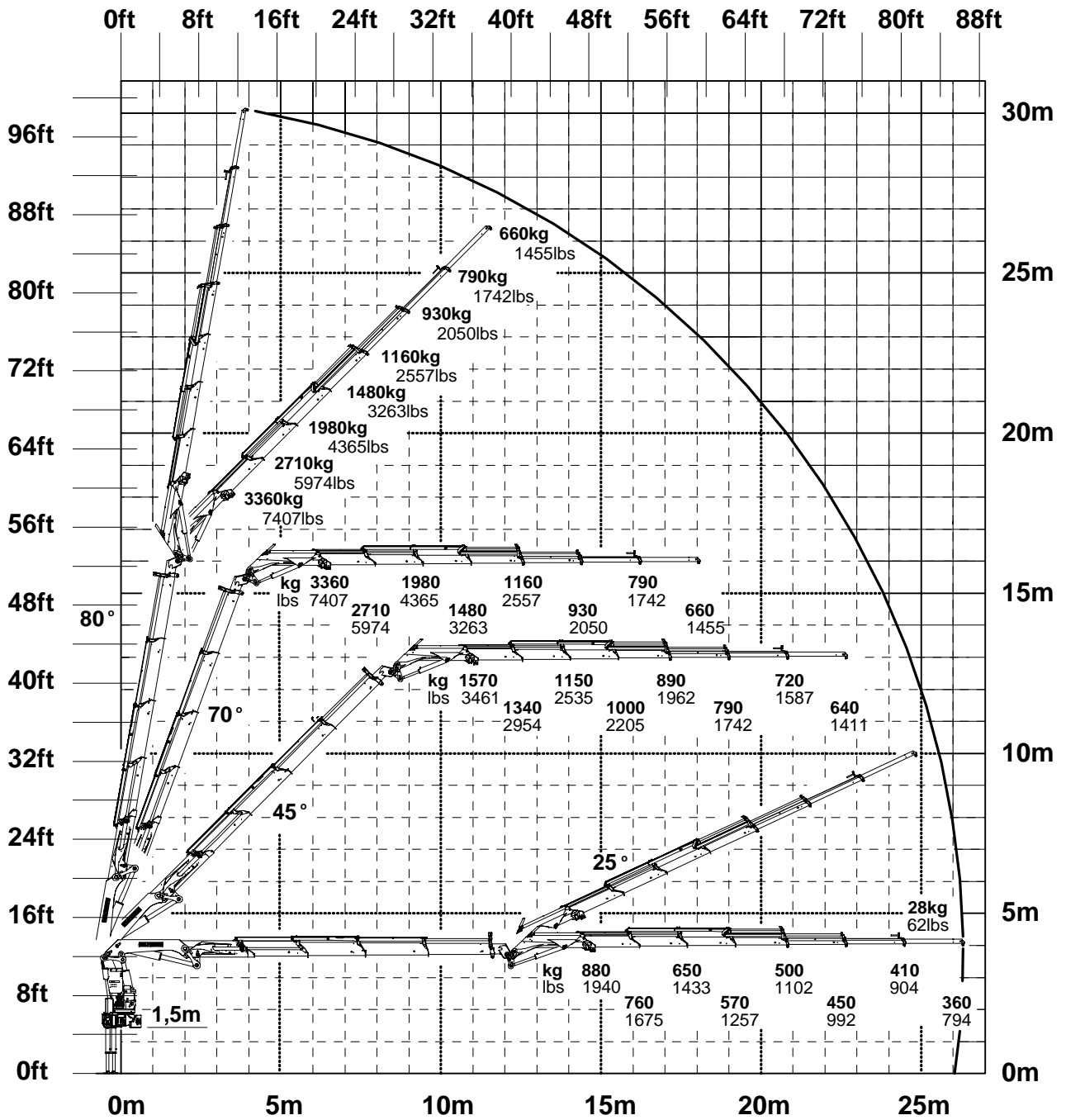

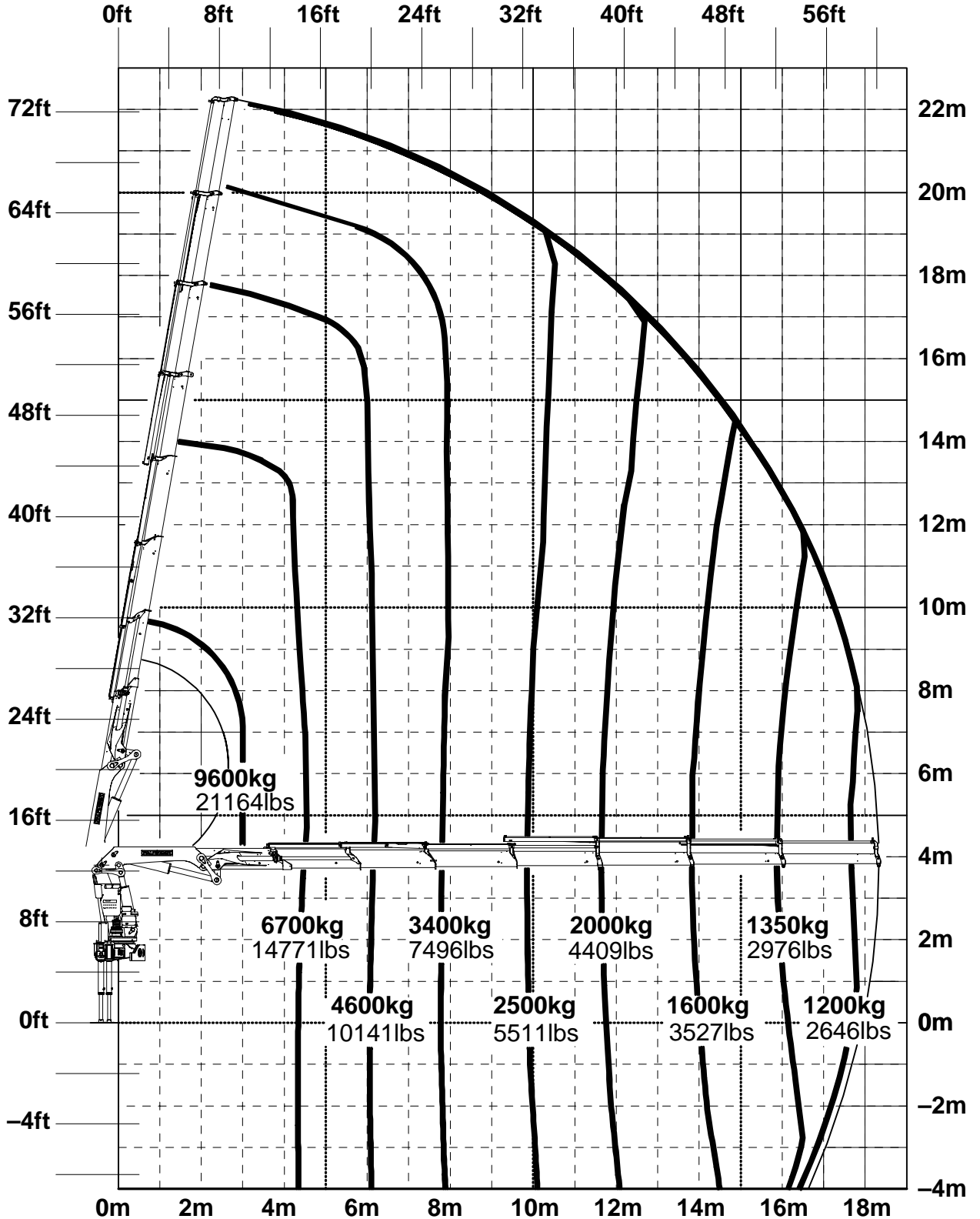

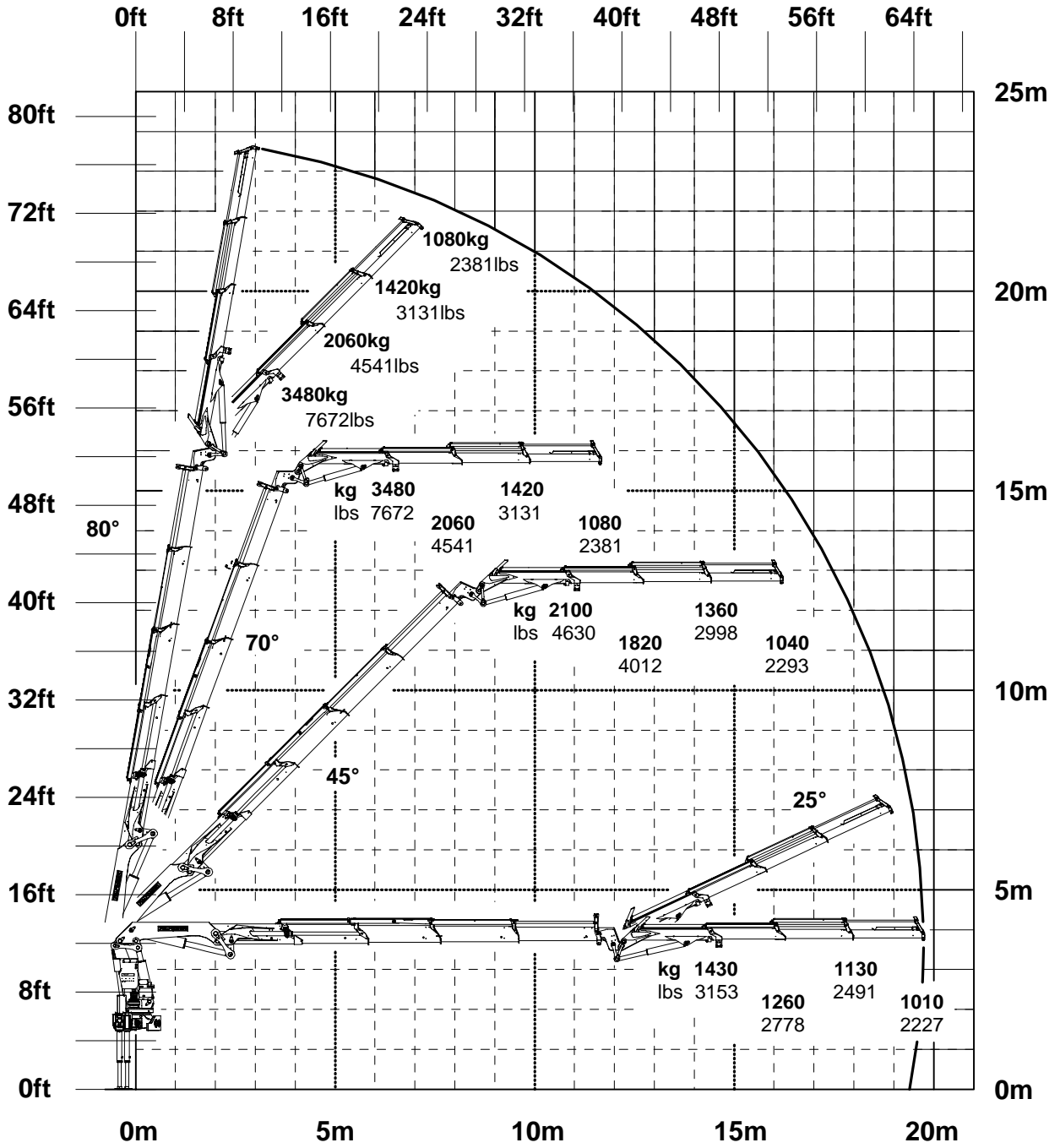

PALFINGERModell *Model* Type
PK 36002**DTS410SHA/03**Kapitel *Chapter* Chapitre**0100**Seite *Page* Page**02/2005**Ausgabe *Edition* Edition343.4 kNm (35 mt)
(253190 ft.lbs)12000 kg
(26460lbs)20.6 m
(67' 7")24.8 m
(81' 4")30.8 m
(101' 1")endlos
endless
sans finite39.24 kNm (4 mt)
(28930 ft.lbs)330 bar (33 MPa)
(4785 psi)80–100 l/min
17.6–22.0 imp.gal./min (21.1–26.4 US gal./min)

	2(A)	3(B)	4(C)	5(D)	6(E)	7(F)	8(G)
	7.7 m (25' 3")	9.6 m (31' 6")	11.6 m (38' 1")	13.8 m (45' 3")	16.0 m (52' 6")	18.3 m (60' 0")	20.6 m (67' 7")
+V 1					18.3 m (60' 0")		22.8 m (74' 10")
+V 2					20.4 m (66' 11")		24.8 m (81' 4")

	3495 kg (7705 lbs)	3745 kg (8256 lbs)	3990 kg (8796 lbs)	4220 kg (9303 lbs)	4445 kg (9799 lbs)	4670 kg (10295 lbs)	4825 kg (10637 lbs)
+2/4	3535 kg (7793 lbs)	3795 kg (8366 lbs)	4050 kg (8929 lbs)	4300 kg (9480 lbs)	4545 kg (10020 lbs)	4770 kg (10516 lbs)	
+V 1					4525 kg (9976 lbs)		4875 kg (10747 lbs)
+V 2					4595 kg (10130 lbs)		4915 kg (10836 lbs)

	R2X-STZY3	R3X-STZS	R3X-STZY3	R3X-STZY
	25 kg (55 lbs)	320 kg (705 lbs)	345 kg (761 lbs)	405 kg (893 lbs)

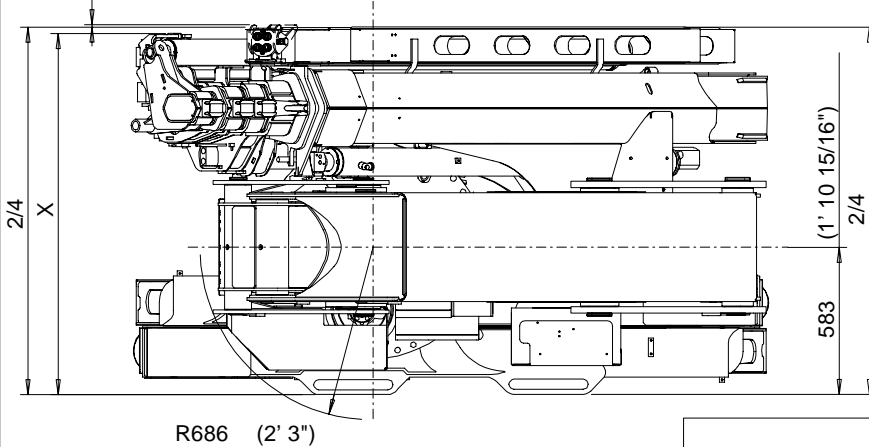
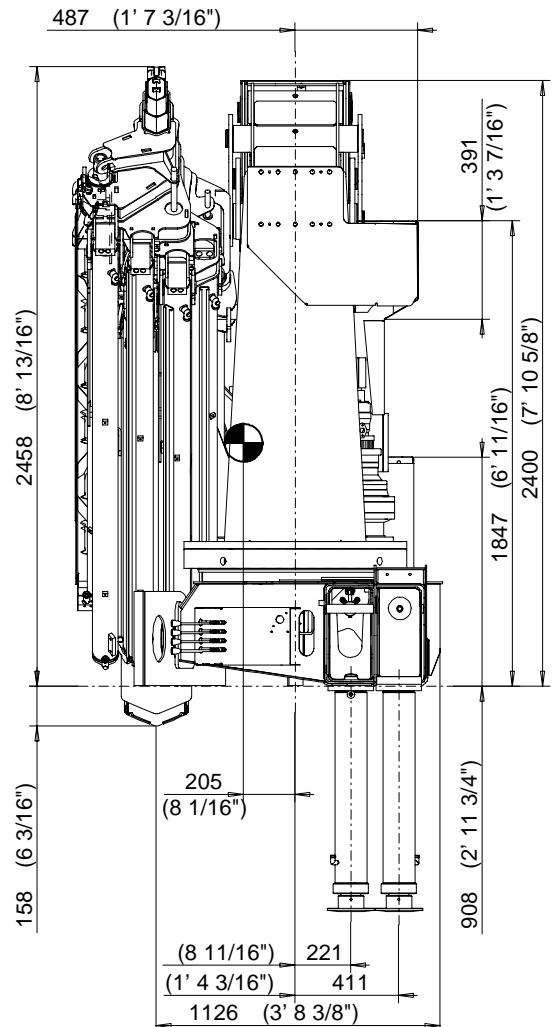
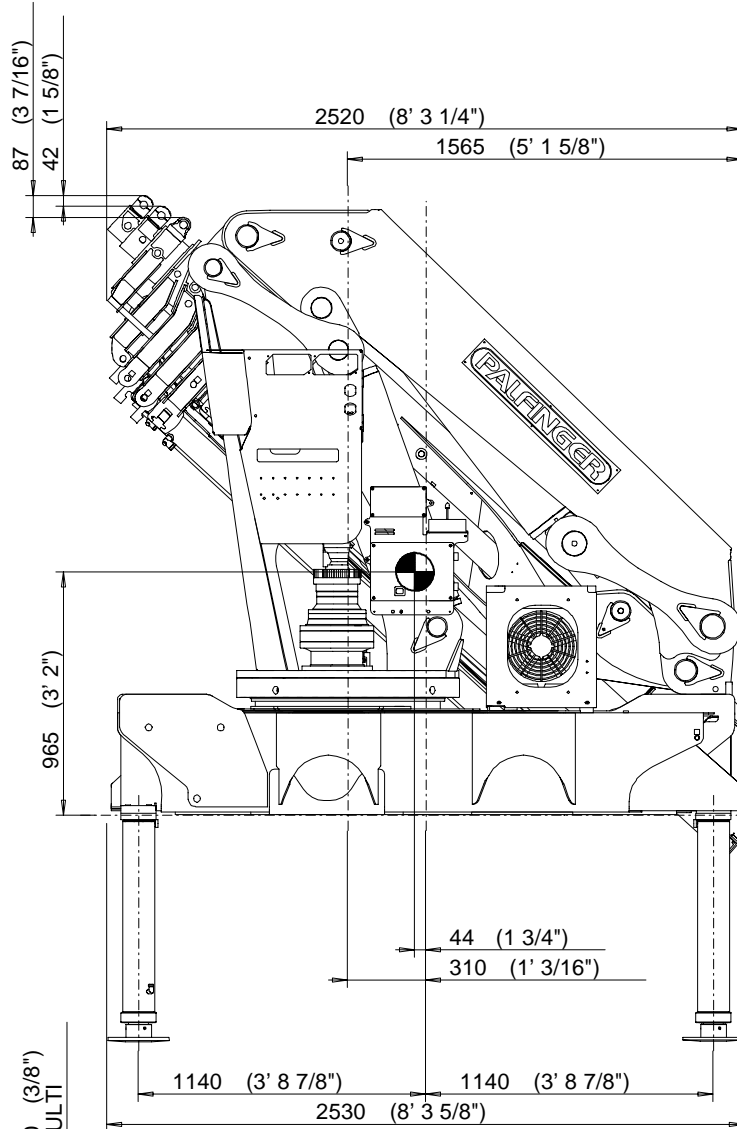

R686 (2' 3")

	X	2/4
2(A)–6(E)	1290 mm 4' 2 13/16"	1455 mm 4' 9 5/16"
7(F)	1425 mm 4' 8 1/8"	1572 mm 5' 1 7/8"
8(G)	1430 mm 4' 8 5/16"	

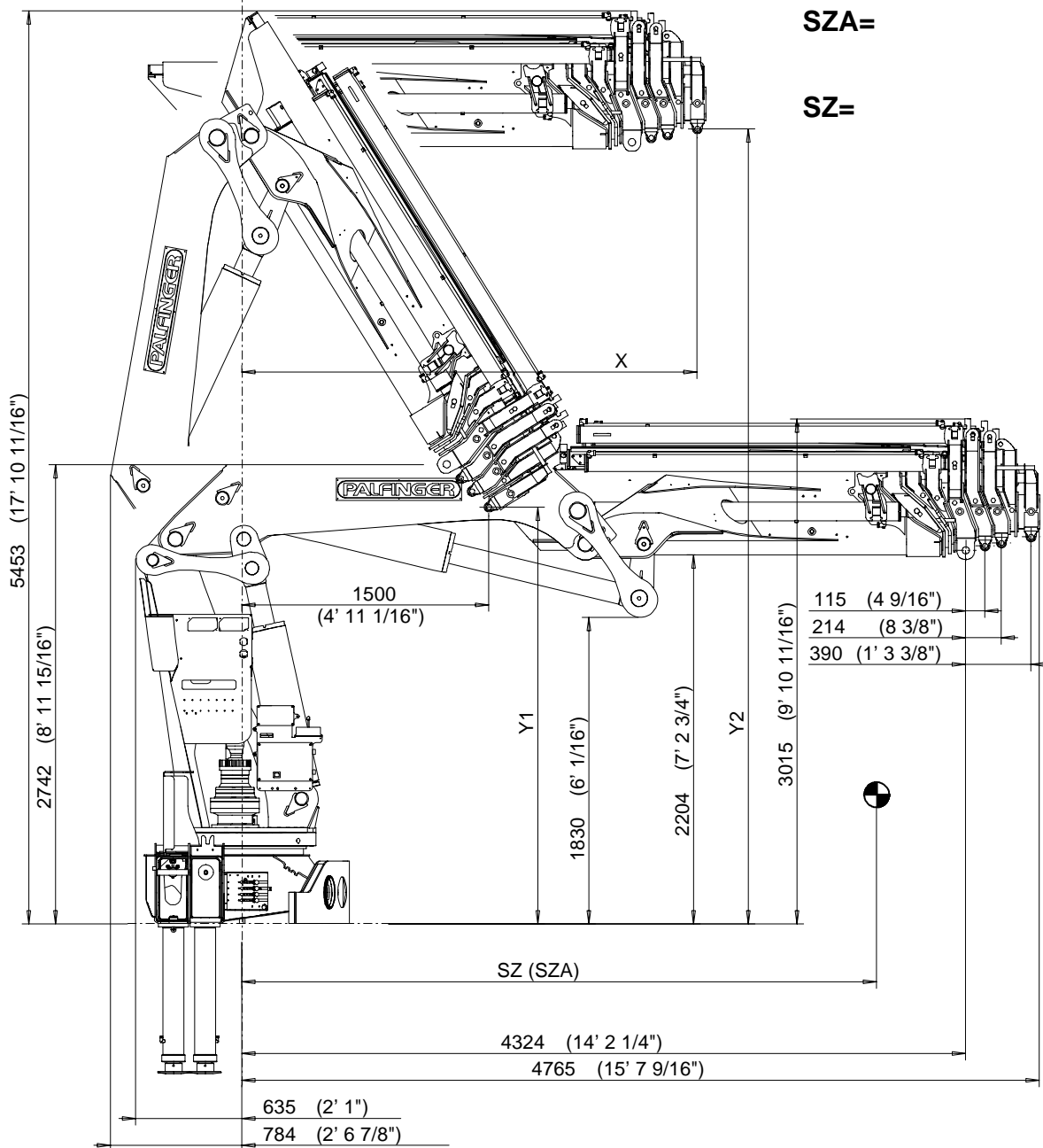

	4(C)	5(D)	6(E)	7(F)	8(G)
X	2330 mm 7' 7 3/4"	2445 mm 8' 1/4"	2543 mm 8' 4 1/8"	2654 mm 8' 8 1/2"	2720 mm 8' 11 1/16"
Y1	2947 mm 9' 8"	2800 mm 9' 2 1/4"	2678 mm 8' 9 7/16"	2541 mm 8' 4 1/16"	2465 mm 8' 1 1/16"
Y2	4670 mm 15' 3 7/8"	4699 mm 15' 5"	4717 mm 15' 5 11/16"	4723 mm 15' 5 15/16"	4753 mm 15' 7 1/8"
SZ	1080 mm 3' 6 1/2"	1200 mm 3' 11 1/4"	1300 mm 4' 3 3/16"	1406 mm 4' 7 3/8"	1460 mm 4' 9 1/2"
SZA	2090 mm 6' 10 5/16"	2630 mm 8' 7 9/16"	3220 mm 10' 6 3/4"	3880 mm 12' 8 3/4"	4330 mm 14' 2 1/2"

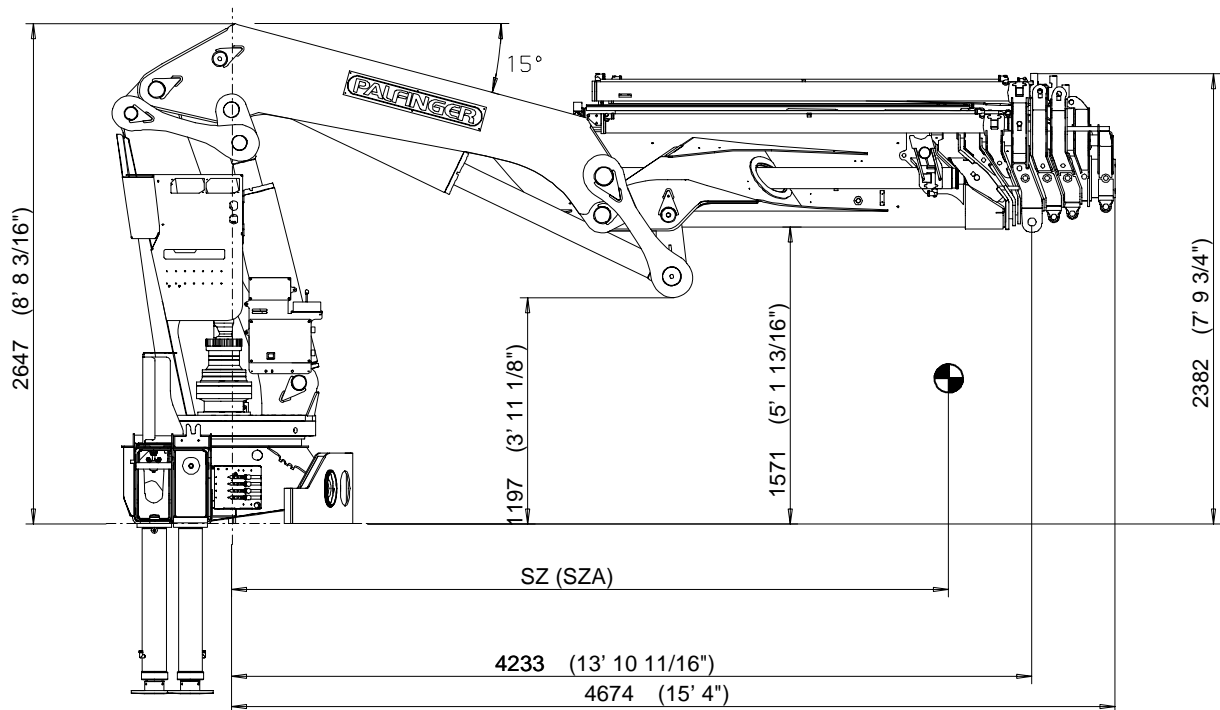

SZA=

SZ=

	4(C)	5(D)	6(E)	7(F)	8(G)
SZ	1050 mm 3' 5 5/16"	1160 mm 3' 9 11/16"	1260 mm 4' 1 5/8"	1368 mm 4' 5 7/8"	1420 mm 4' 7 7/8"
SZA	2060 mm 6' 9 1/8"	2600 mm 8' 6 3/8"	3180 mm 10' 5 3/16"	3840 mm 12' 7 3/16"	4290 mm 14' 7/8"

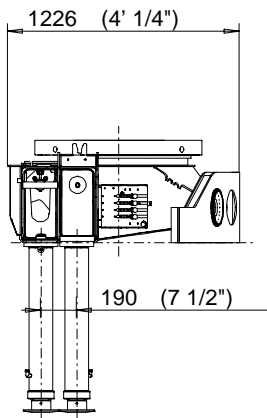
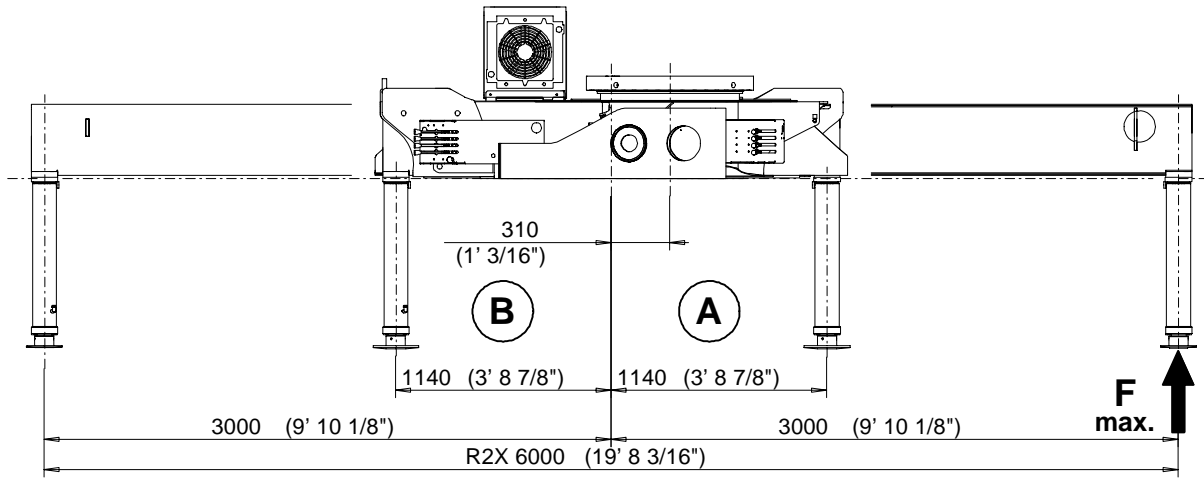

STZS

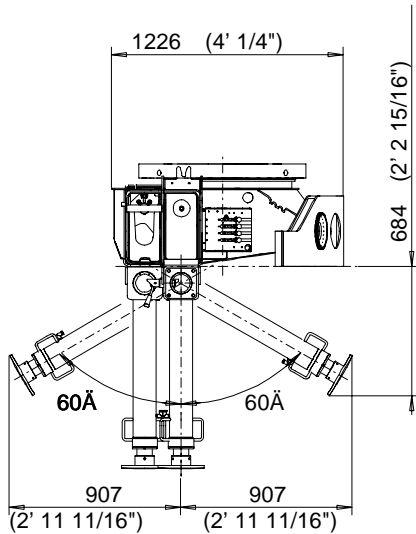
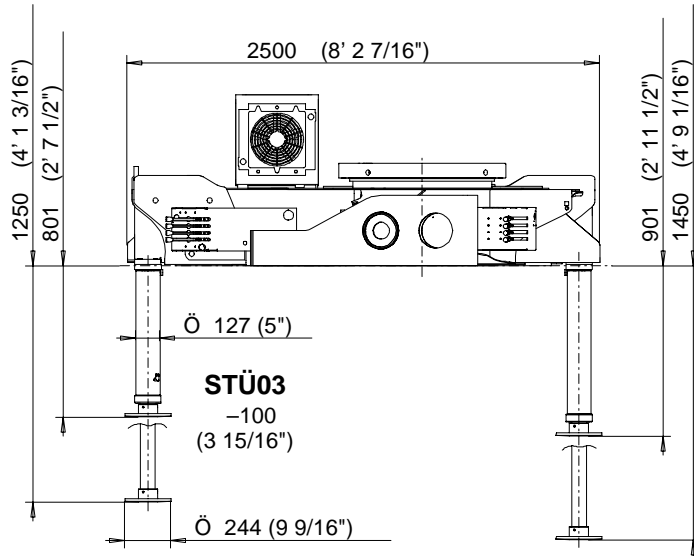

**STZY3
(60°)**

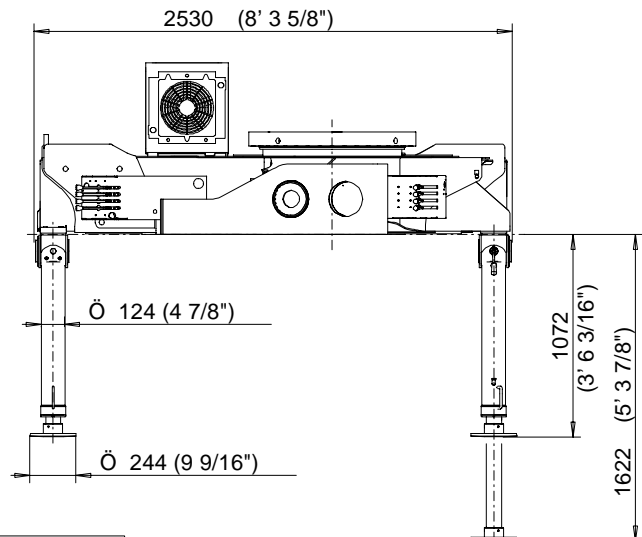

	STZS	STZY3	F max. A	F max. B
R2X	1190 kg 2623 lbs	1215 kg 2679 lbs	143 kN 32140 lbs	135 kN 30340 lbs

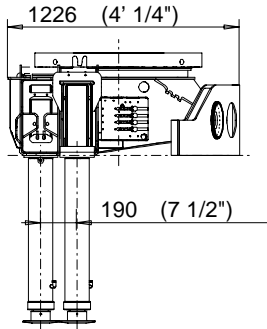
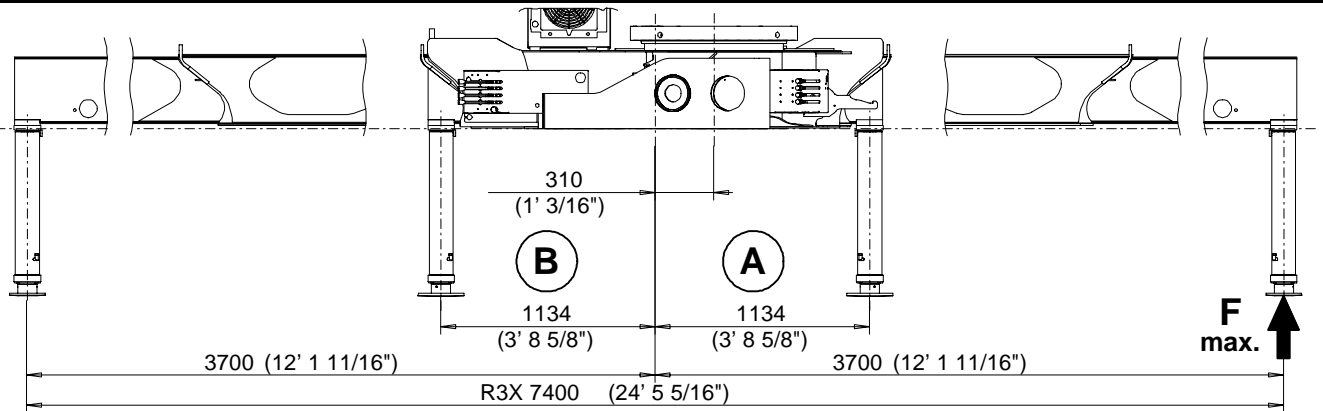

STZS

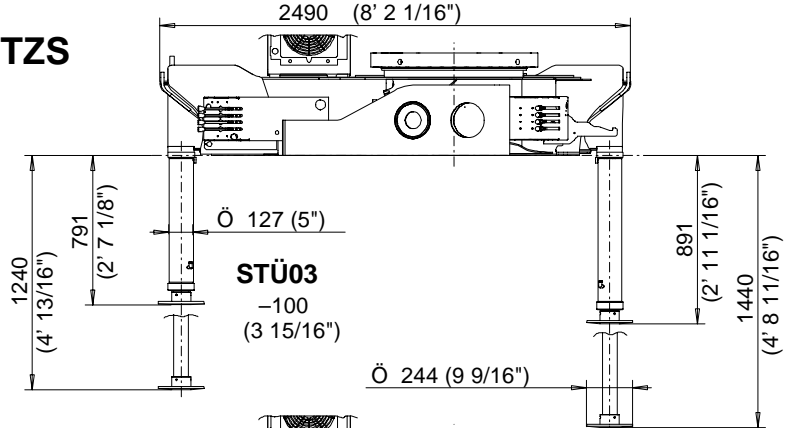

STÜ03
-100
(3 15/16")

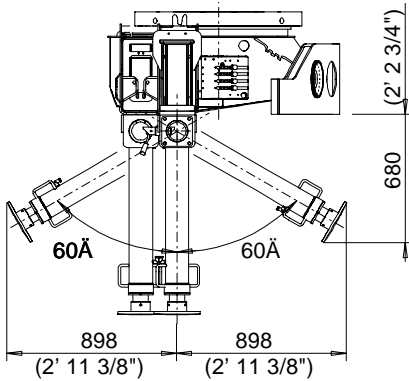

STZY3
(60°)

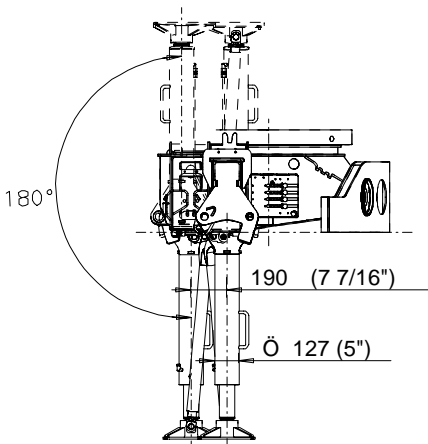
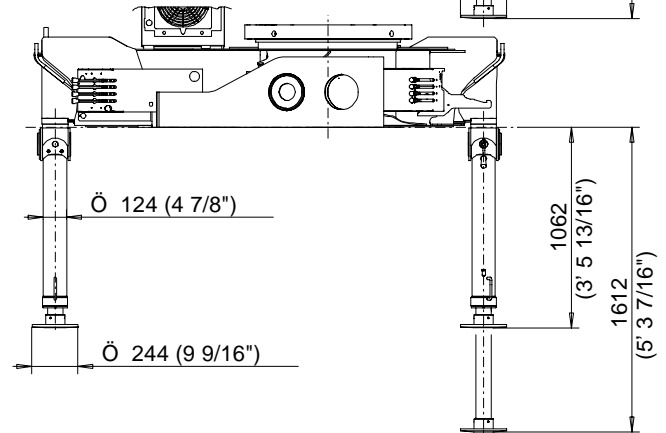

STZY
(180°)

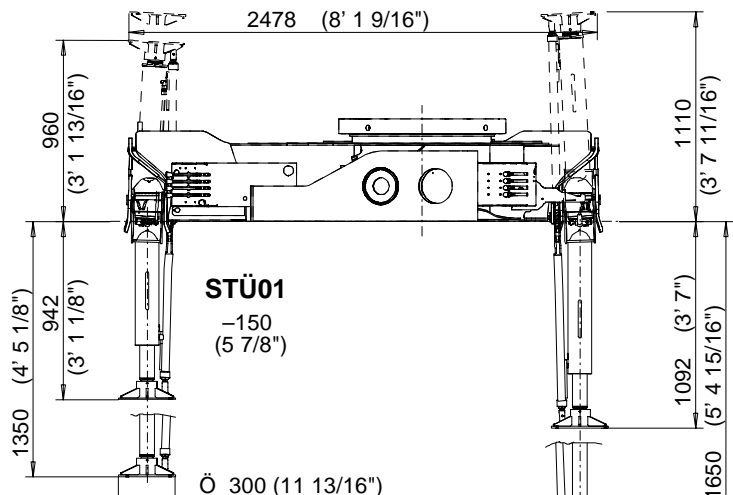

STÜ01
-150
(5 7/8")

	STZS	STZY3	STZY	F max. A	F max. B
R3X	1510 kg (3329 lbs)	1535 kg (3384 lbs)	1595 kg (3516 lbs)	122 kN (27420 lbs)	115 kN (25840 lbs)

Konstruktionsänderungen vorbehalten, fertigungstechn. Toleranzen müssen berücksichtigt werden.
 Subject to change, production tolerances have to be taken into account.
 Sous réserve de modifications de conception. Les tolérances relatives à la technique de production doivent être prises en considération.

Konstruktionsänderungen vorbehalten, fertigungstechn. Toleranzen müssen berücksichtigt werden.
 Subject to change without notice, manufacturing tolerances must be taken into account.
 Sous réserve de modifications de conception. Les tolérances relatives à la technique de production doivent être prises en considération.

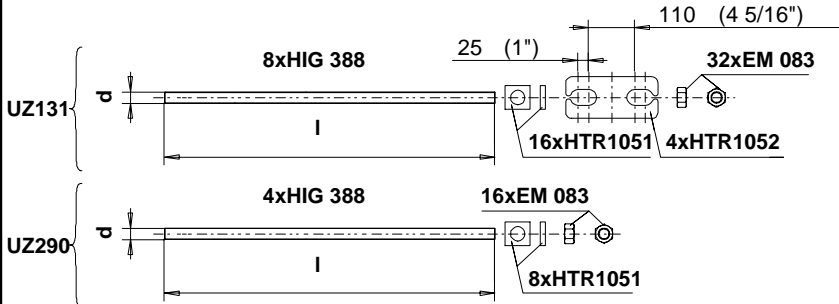
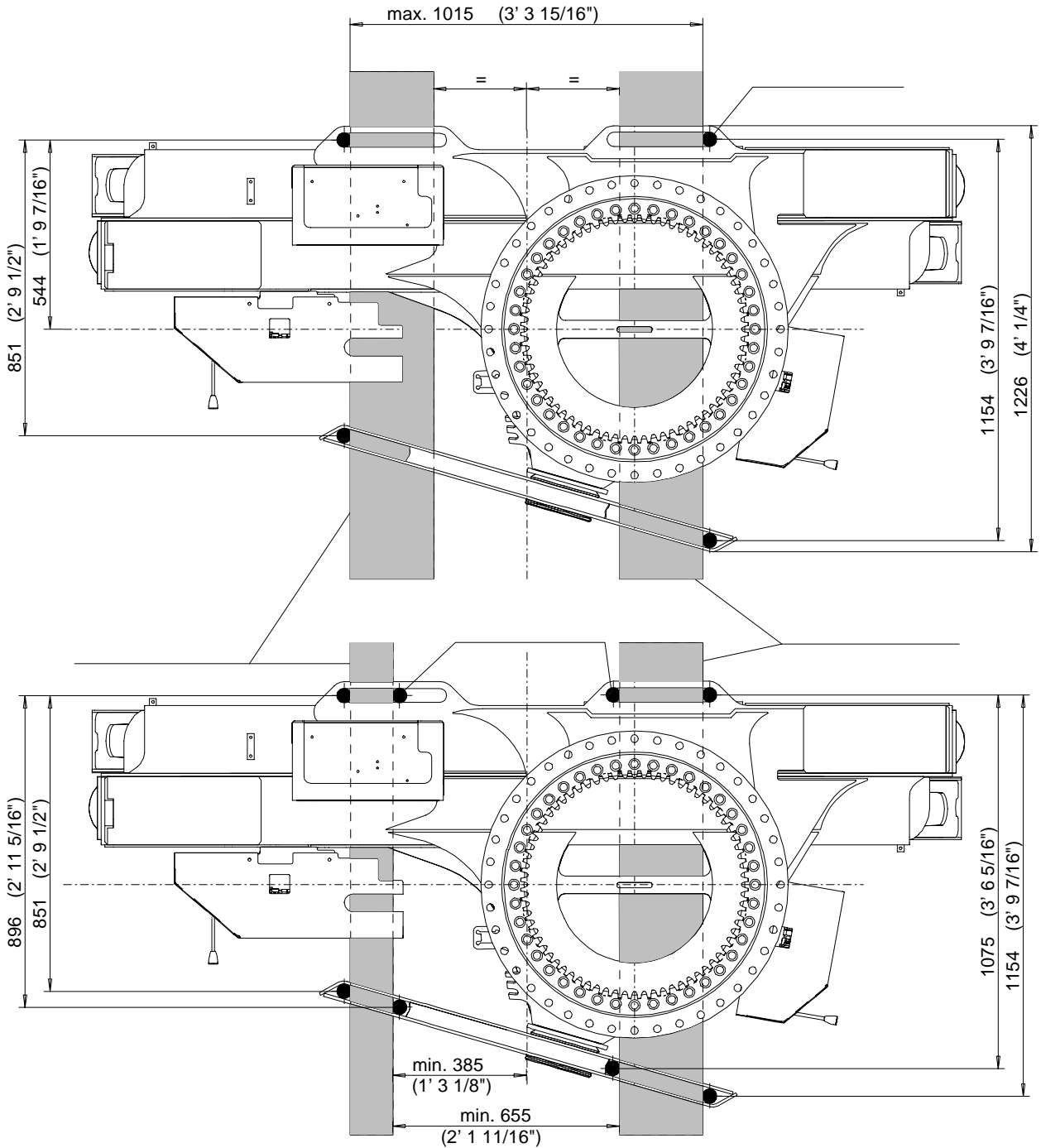

	d	l		
HIG 388	M36x1.5	1450 mm 4' 9 1/16"	42 Cr Mo 4 V	1550 Nm

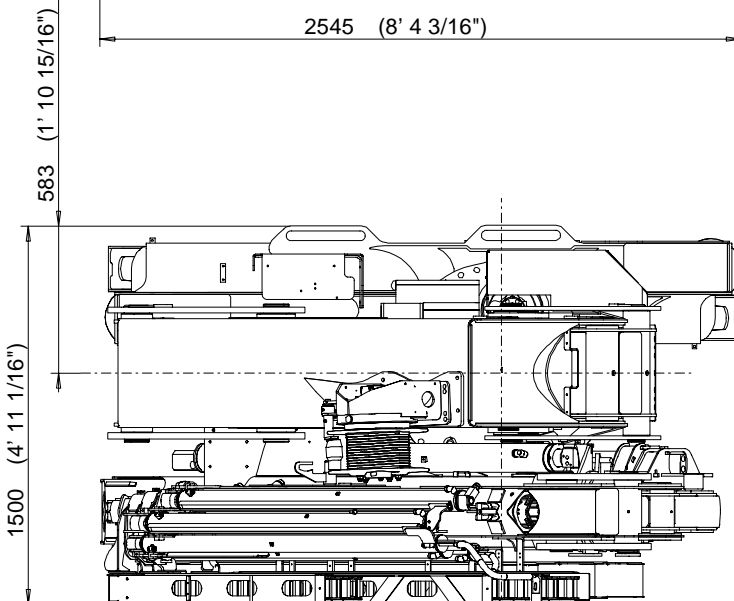
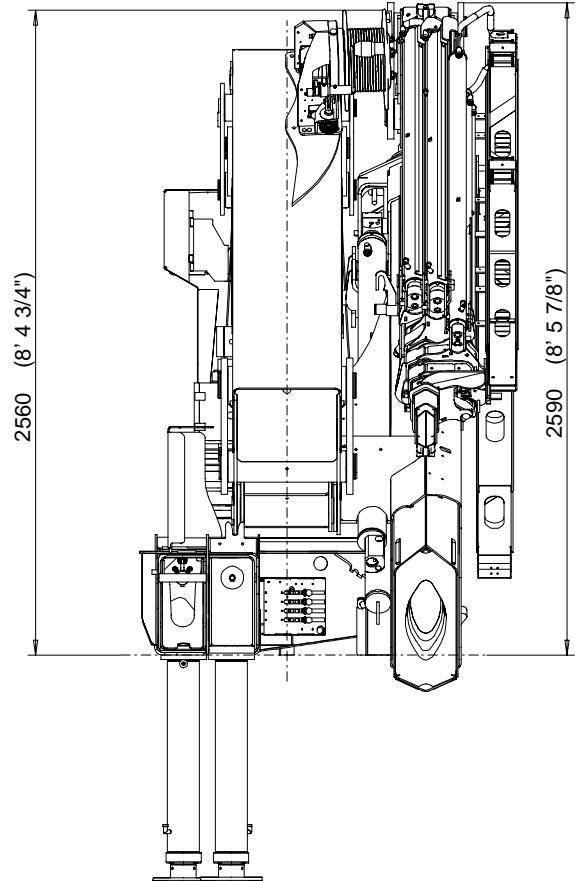
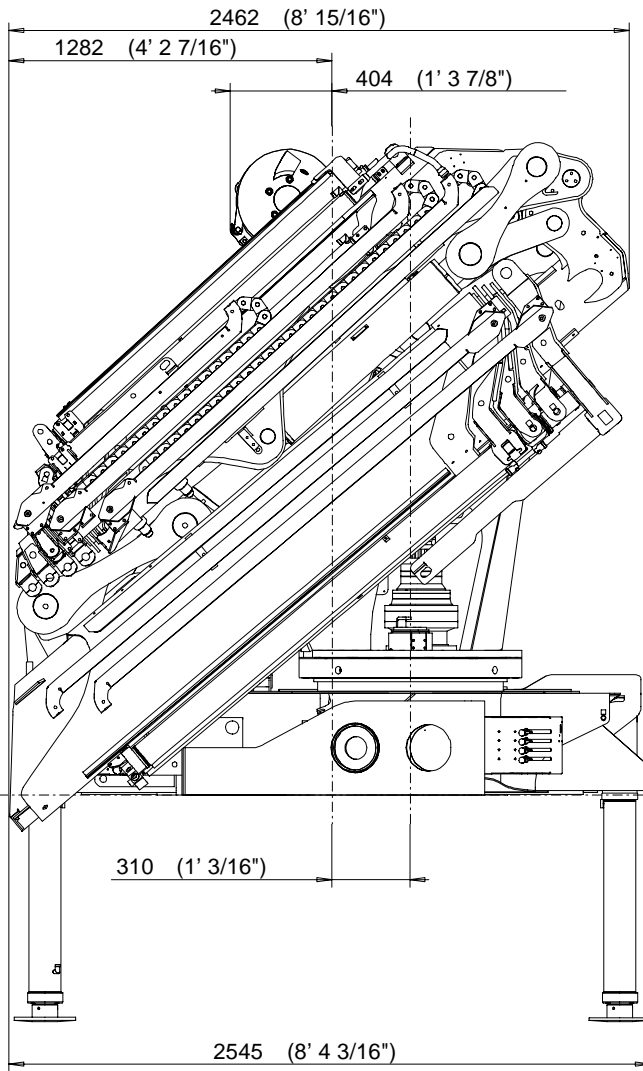

PK 36002C PJ115C	4960 kg 10935 lbs
+2/4 PJ115C	60 kg 132 lbs
PK 36002C PJ115C V1	5005 kg 11034 lbs
PK 36002C PJ115C V2	5045 kg 11122 lbs
PK 36002C PJ115D	5045 kg 11122 lbs
+2/4 PJ115D	70 kg 154 lbs
PK 36002C PJ115D V1	5085 kg 11210 lbs
PK 36002C PJ115D V2	5110 kg 11265 lbs

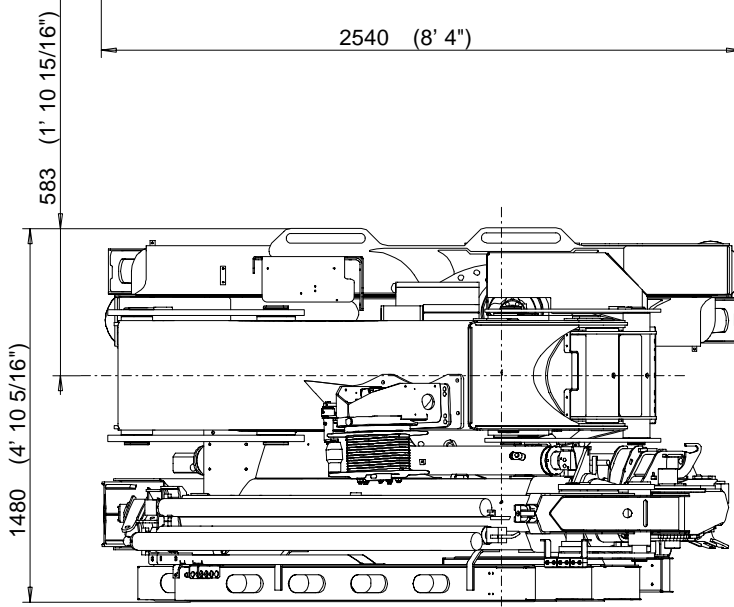
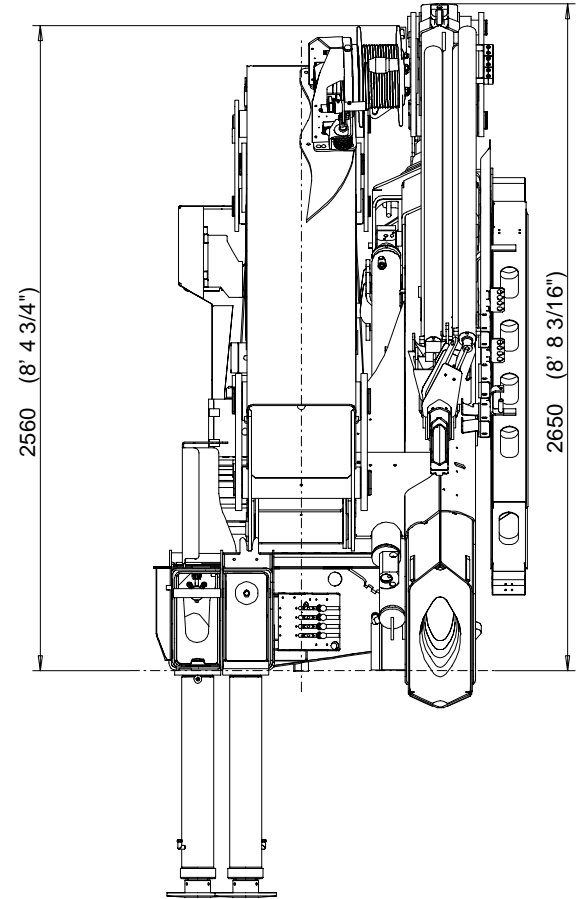
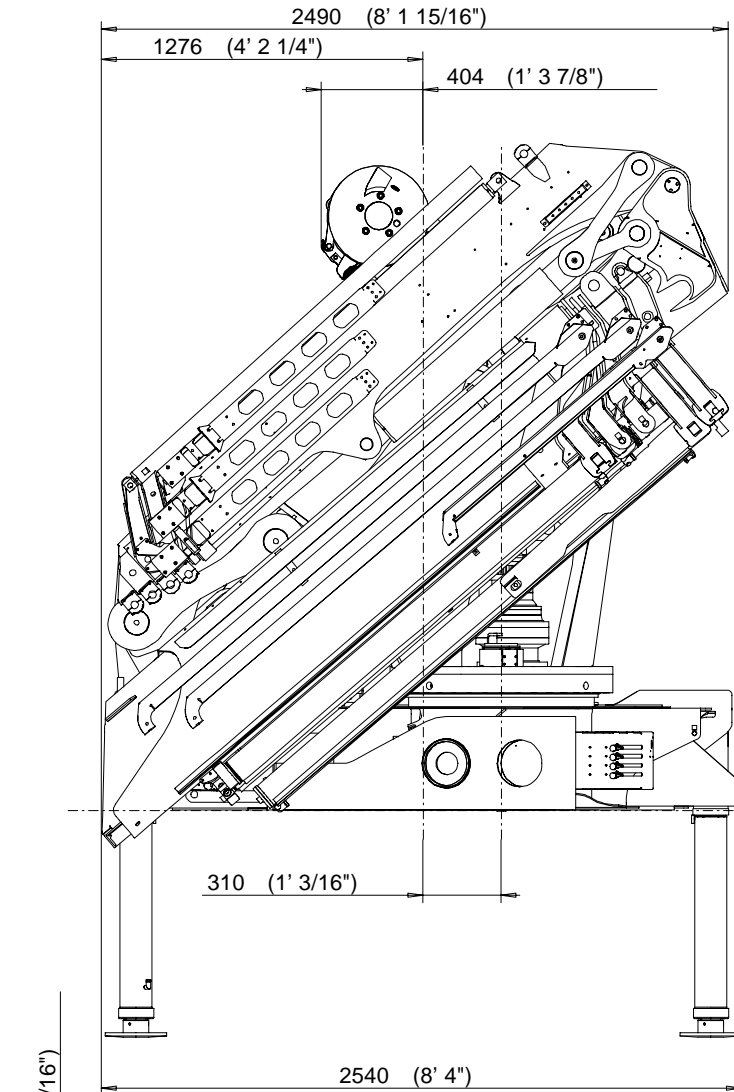

PK 36002D PJ085B	4950 kg 10913 lbs
+2/4 PJ085B	40 kg 88 lbs
PK 36002D PJ085B V1	4990 kg 11001 lbs
PK 36002D PJ085B V2	5020 kg 11067 lbs

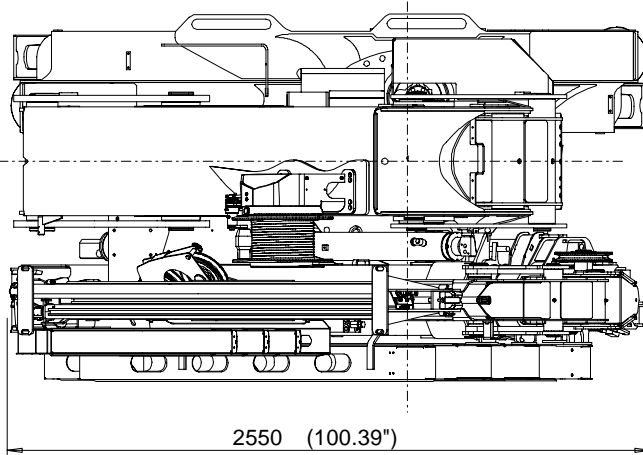
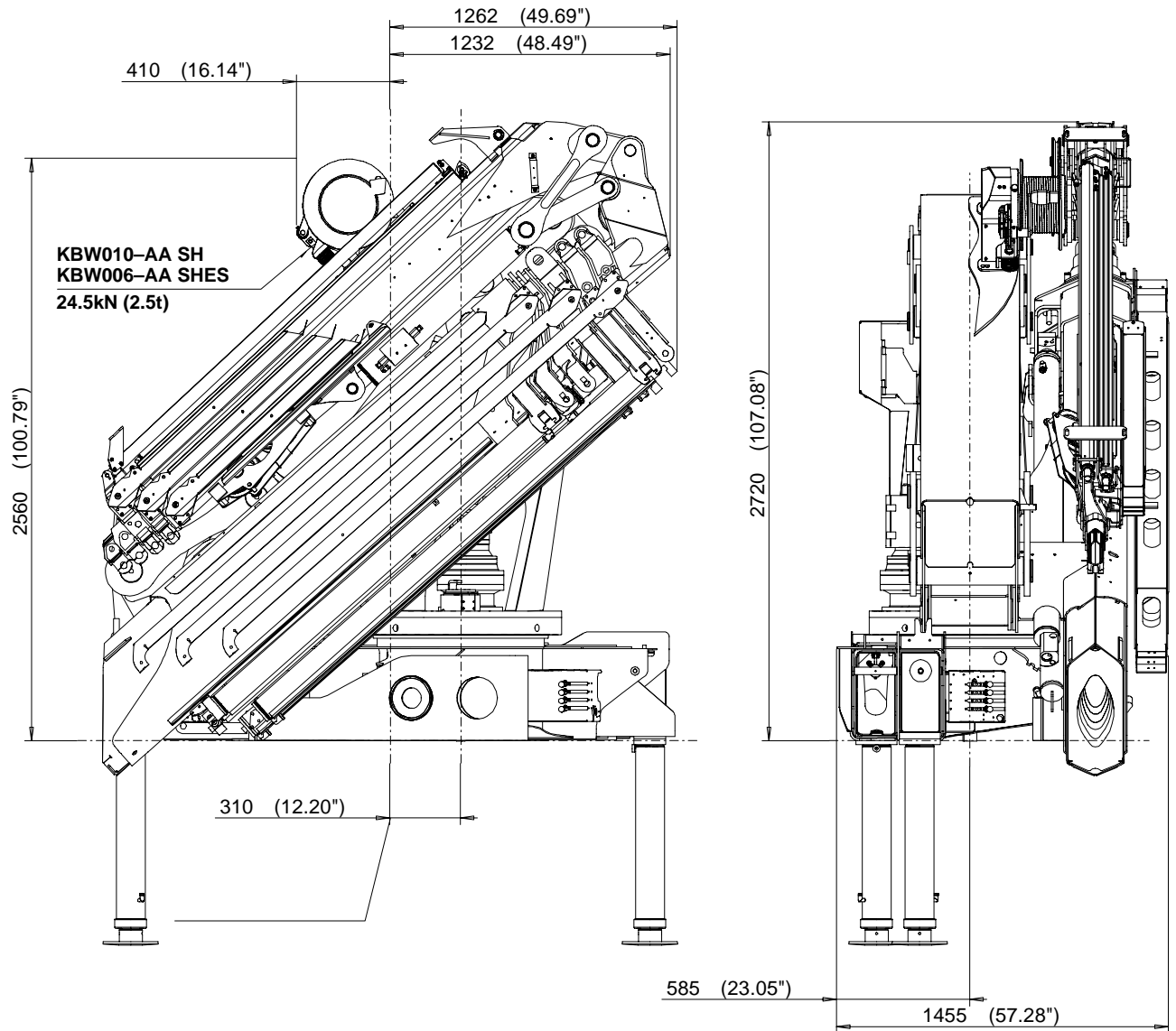

PK 36002E PJ060A	4966 kg (10948 lbs)
PK 36002E PJ060V1A	5008 kg (11041 lbs)
PK 36002E PJ060V2A	5043 kg (11118 lbs)
+2/4 PJ060A	48 kg (106 lbs)
PK 36002E PJ060B	5030 kg (11089 lbs)
PK 36002E PJ060V1B	5065 kg (11166 lbs)
PK 36002E PJ060V2B	5092 kg (11226 lbs)
+2/4 PJ060B	53 kg (117 lbs)

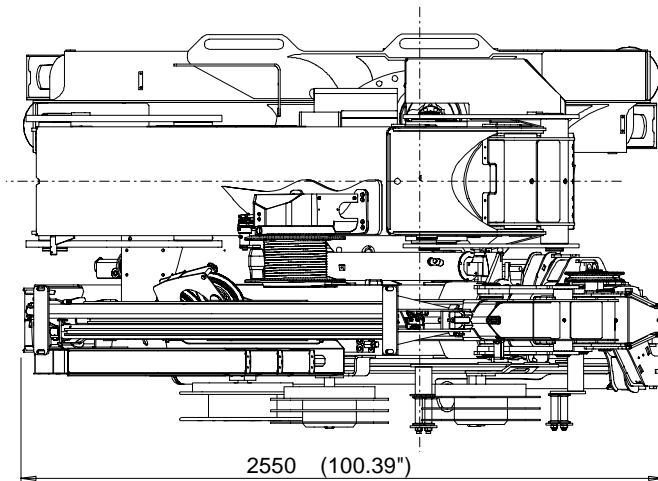
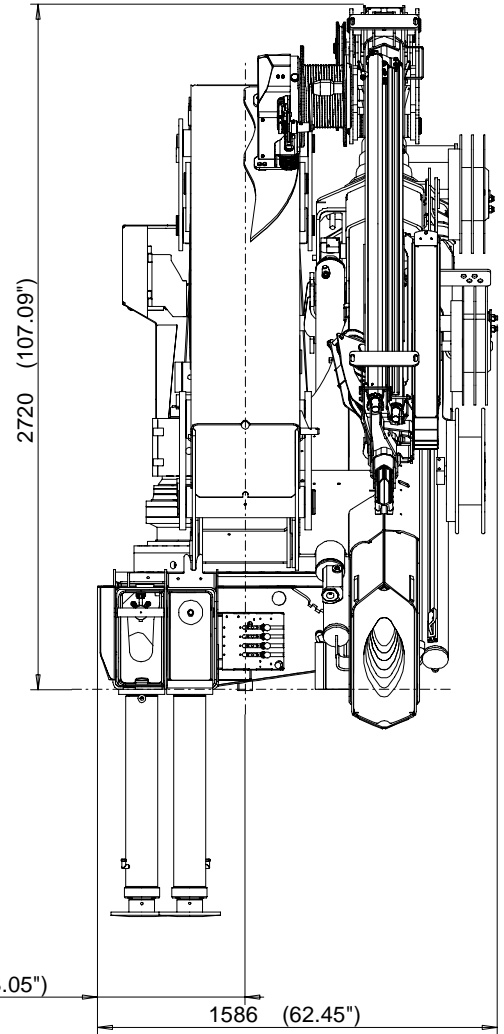
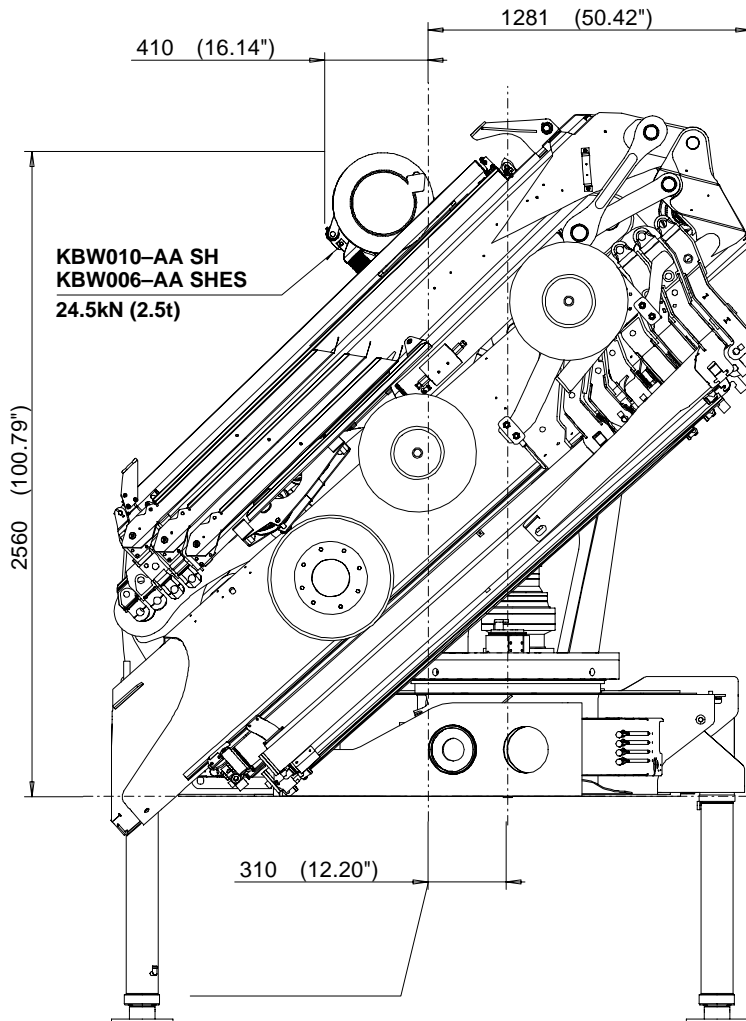

PK 36002F PJ 060A	5176 kg (11411 lbs)
PK 36002F PJ 060V1A	5218 kg (11504 lbs)
PK 36002F PJ 060V2A	5253 kg (11581 lbs)
+2/4 PJ060A	48 kg (106 lbs)
PK 36002F PJ 060B	5240 kg (11552 lbs)
PK 36002F PJ 060V1B	5275 kg (11629 lbs)
PK 36002F PJ 060V2B	5302 kg (11689 lbs)
+2/4 PJ060B	53 kg (117 lbs)

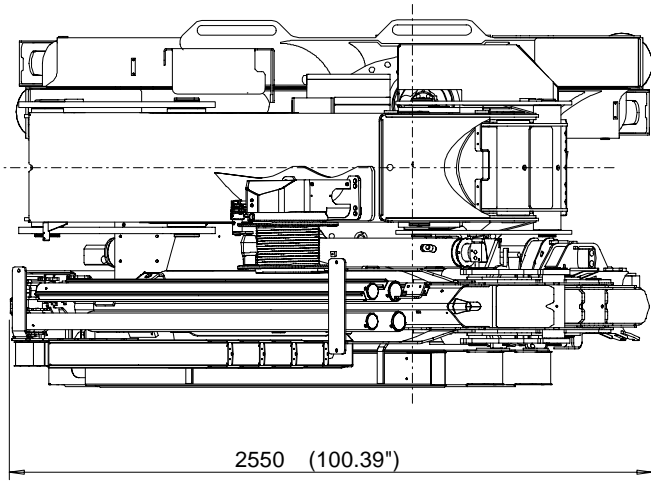
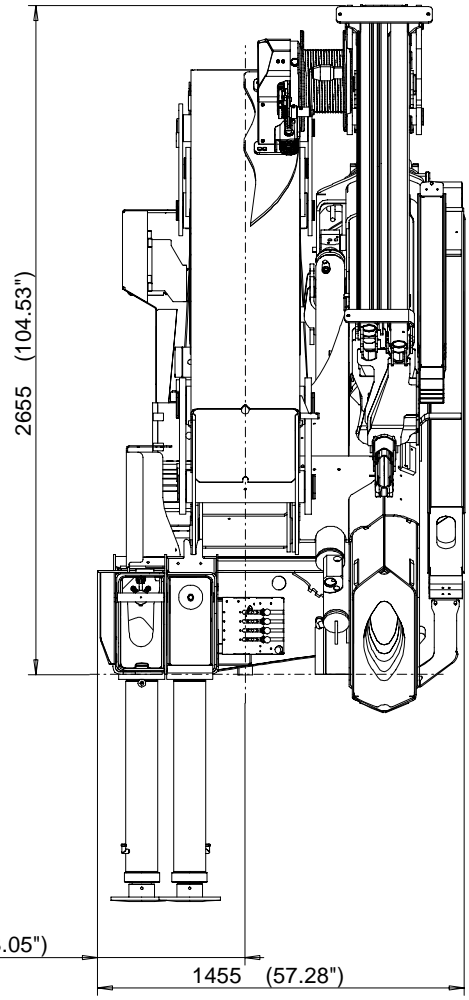
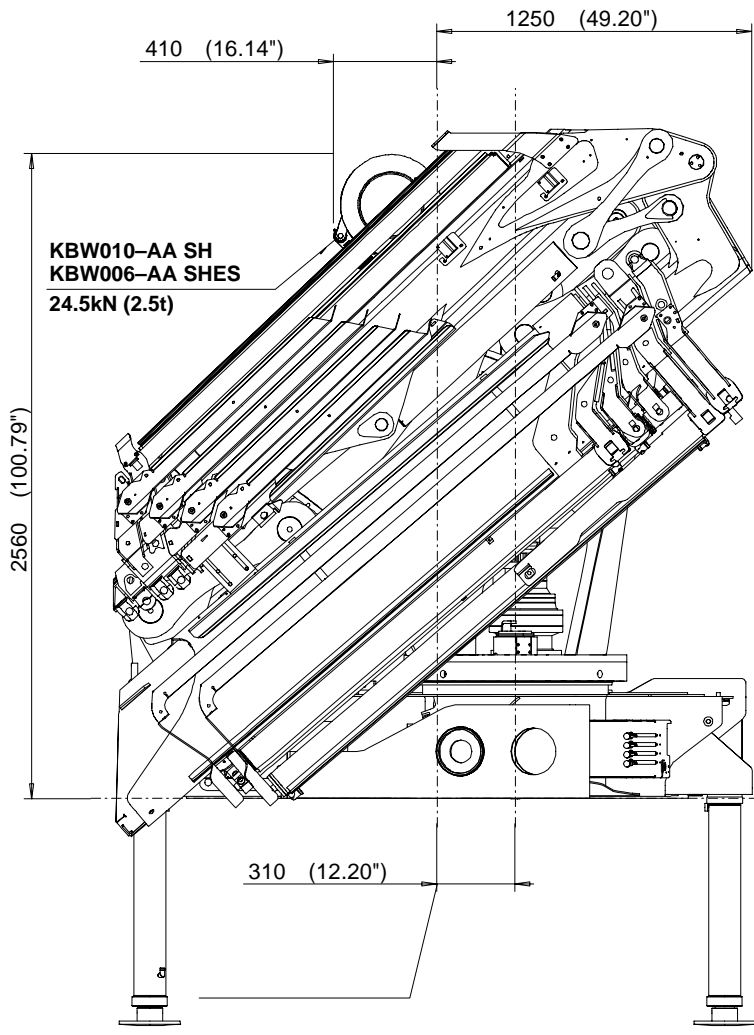

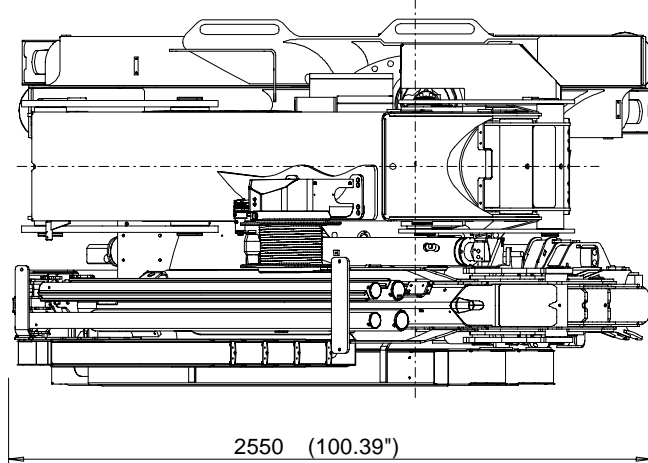
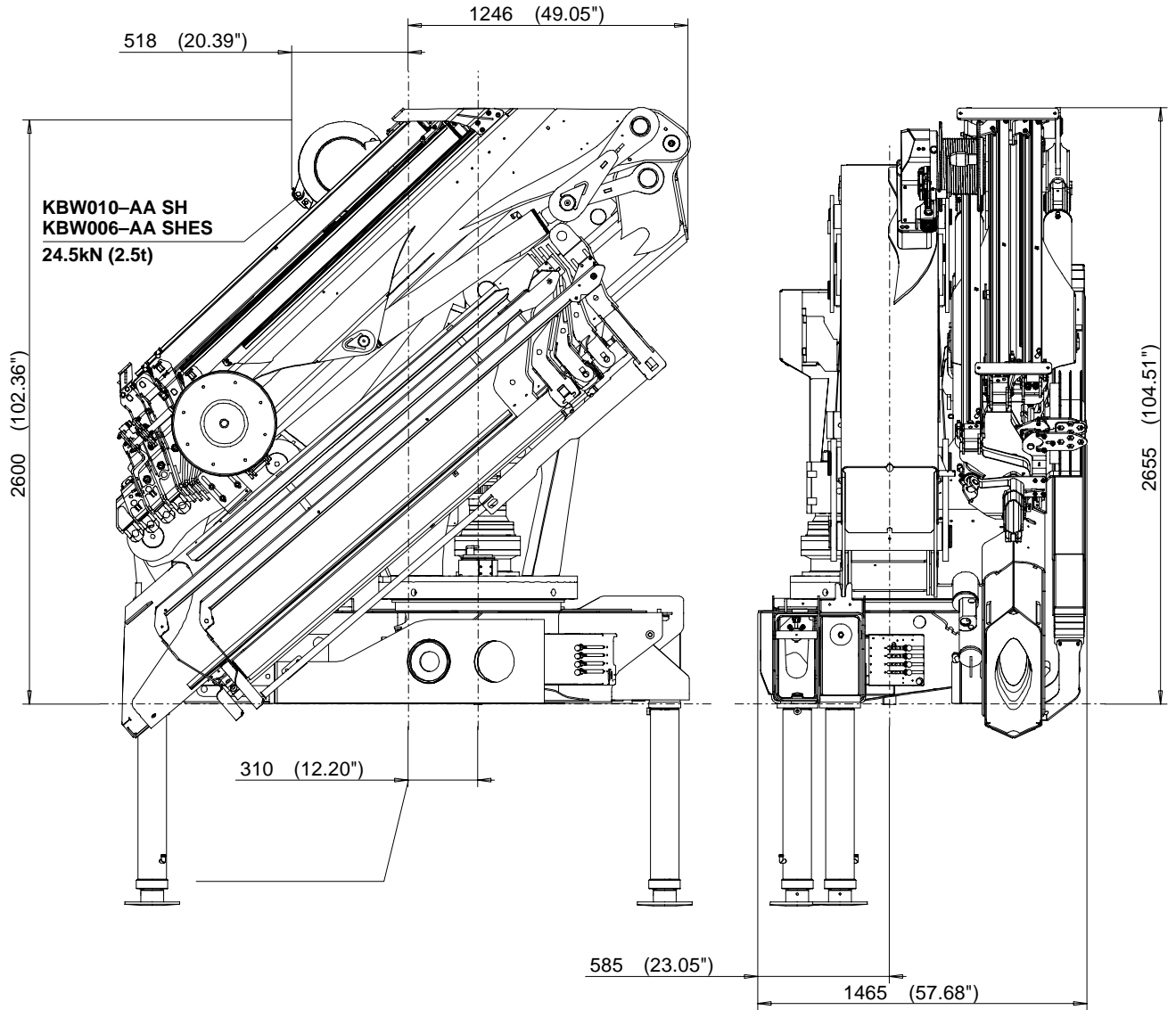

PK 36002D PJ080B	4997 kg (11016 lbs)
+2/4 PJ080B	55 kg (121 lbs)
PK 36002D PJ080C	5090 kg (11221 lbs)
PK 36002D PJ080V1C	5125 kg (11299 lbs)
PK 36002D PJ080V2C	5147 kg (11347 lbs)
+2/4 PJ080C	65 kg (143 lbs)





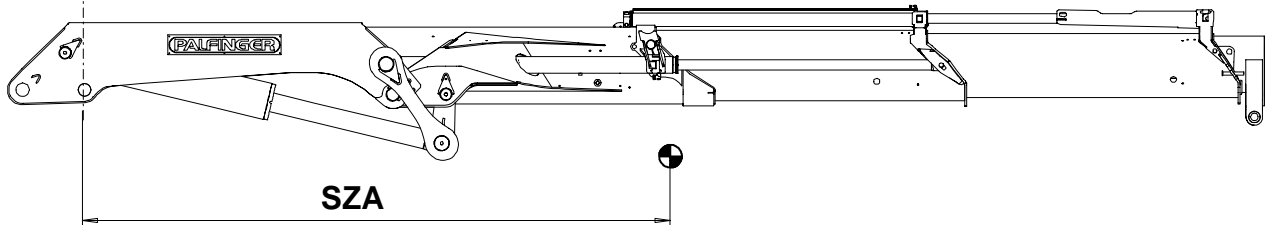
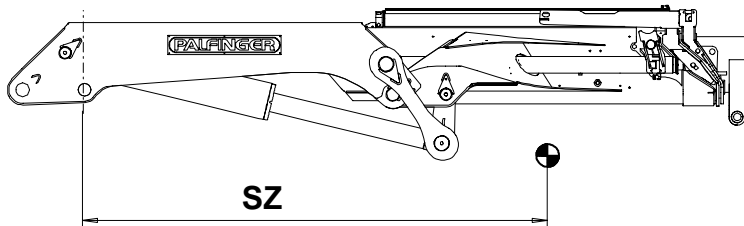









PK 36002C PJ125C	5123 kg (11294 lbs)
PK 36002C PJ125E	5335 kg (11761 lbs)
PK 36002C PJ125EV1	5363 kg (11823 lbs)
+2/4 PJ125	55 kg (121 lbs)

		SZ 	SZA 
PK 36002 A	1485 kg 14.57 kN 3274 lbs	2111 mm 6' 11 1/8"	2864 mm 9' 4 3/4"
PK 36002 B	1735 kg 17.02 kN 3825 lbs	2259 mm 7' 4 15/16"	3619 mm 11' 10 1/2"
PK 36002 C	1980 kg 19.42 kN 4365 lbs	2378 mm 7' 9 5/8"	4427 mm 14' 6 5/16"
PK 36002 D	2210 kg 21.68 kN 4872 lbs	2462 mm 8' 15/16"	5226 mm 17' 1 3/4"
PK 36002 E	2435 kg 23.89 kN 5368 lbs	2536 mm 8' 3 13/16"	6063 mm 19' 10 11/16"
+V 1	2519 kg 24.71 kN 5368 lbs	2563 mm 8' 4 7/8"	6355 mm 20' 10 3/16"
+V 2	2582 kg 25.32 kN 5368 lbs	2585 mm 8' 5 3/4"	6565 mm 19' 10 11/16"
PK 36002 F	2660 kg 26.1kN 5864 lbs	2602 mm 8' 6 7/16"	6942 mm 22' 9 5/16"
PK 36002 G	2815 kg 27.62 kN 6206 lbs	2639 mm 8' 7 7/8"	7594 mm 24' 11"
+V 1	2865 kg 28.11 kN 6316 lbs	3713 mm 12' 2 3/16"	7839 mm 25' 8 5/8"
+V 2	2905 kg 28.5 kN 6404 lbs	2674 mm 8' 9 1/4"	8000 mm 26' 2 15/16"



	STZS	STZY3	STZY
R2X	2010 kg 4431 lbs	2035 kg 4486 lbs	
R3X	2330 kg 5137 lbs	2355 kg 5192 lbs	2415 kg 5324 lbs

	0200		0601
		(0746616—>)	
	0300		0700
		(—>0746615)	
	0400		0701
		(0746616—>)	
  	0500	 	0800
	0600		0900
(—>0746615)			
		 	1000

--	--	--	--

1	13	24
2	14	25
3	15	26
4	16	27
5	17	28
6	18	29
7	19	30
8	20	31
9	21	32
10	22	33
11	23	34
12		35

--	--	--

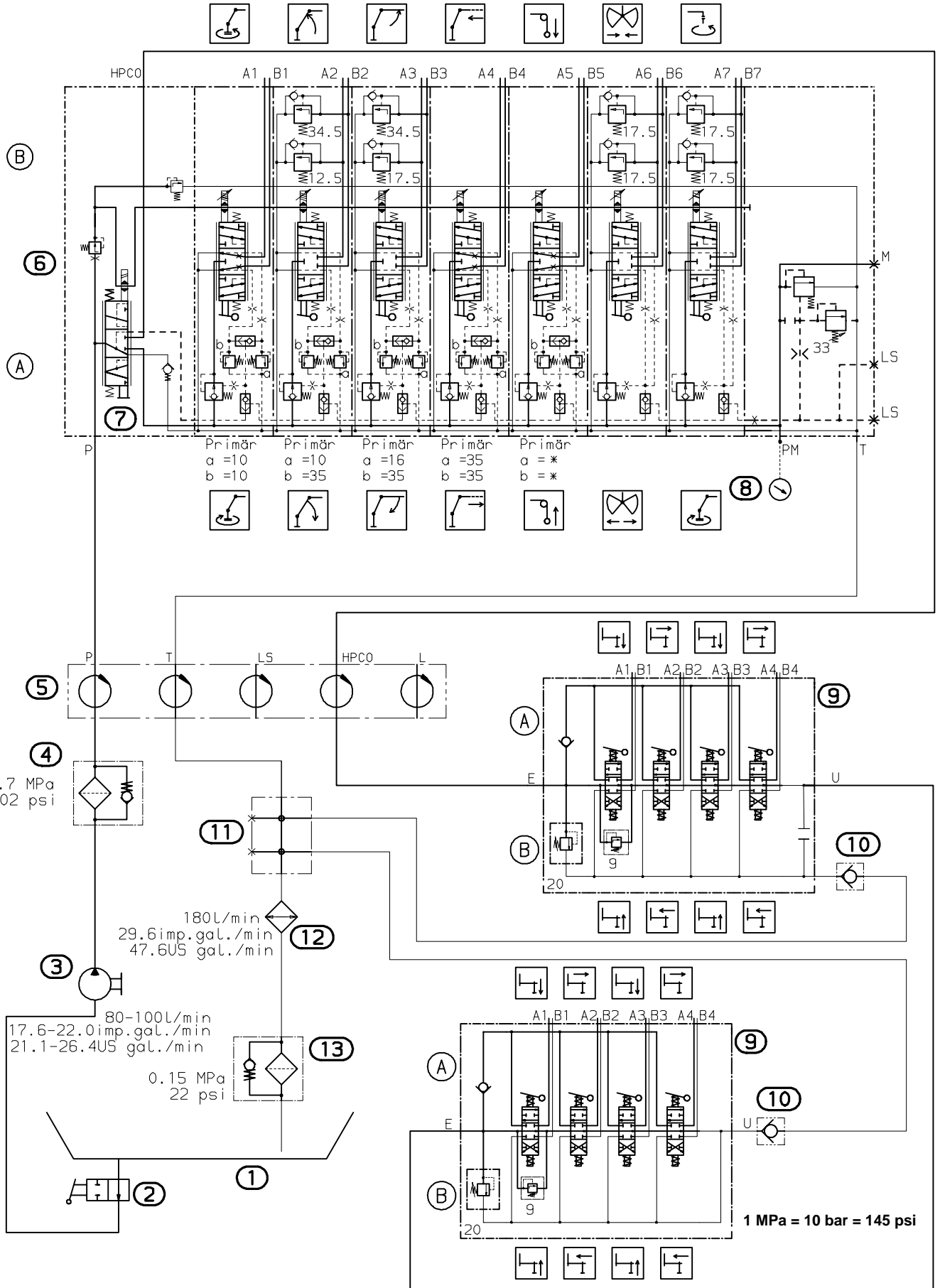

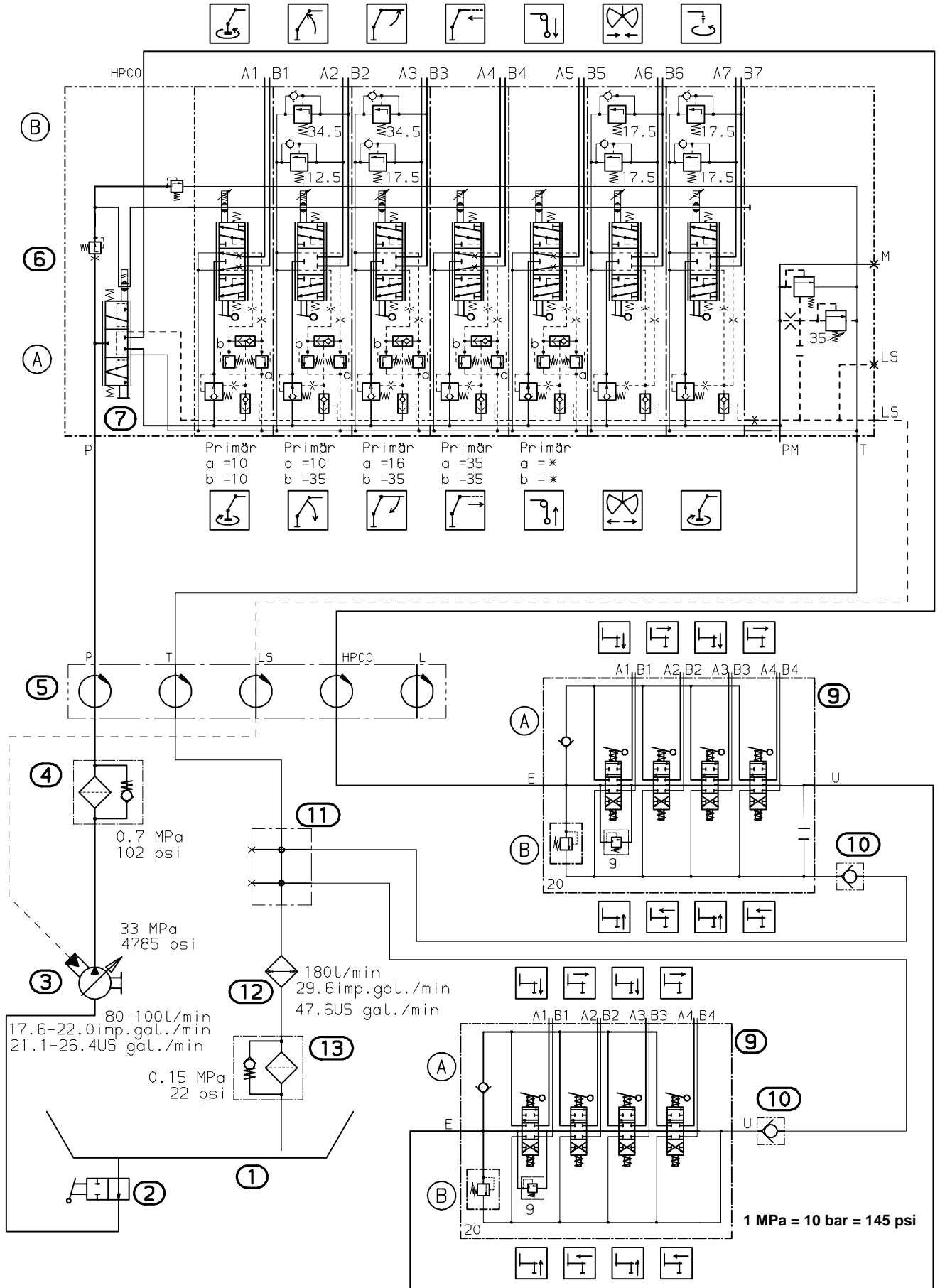

→ 100049649

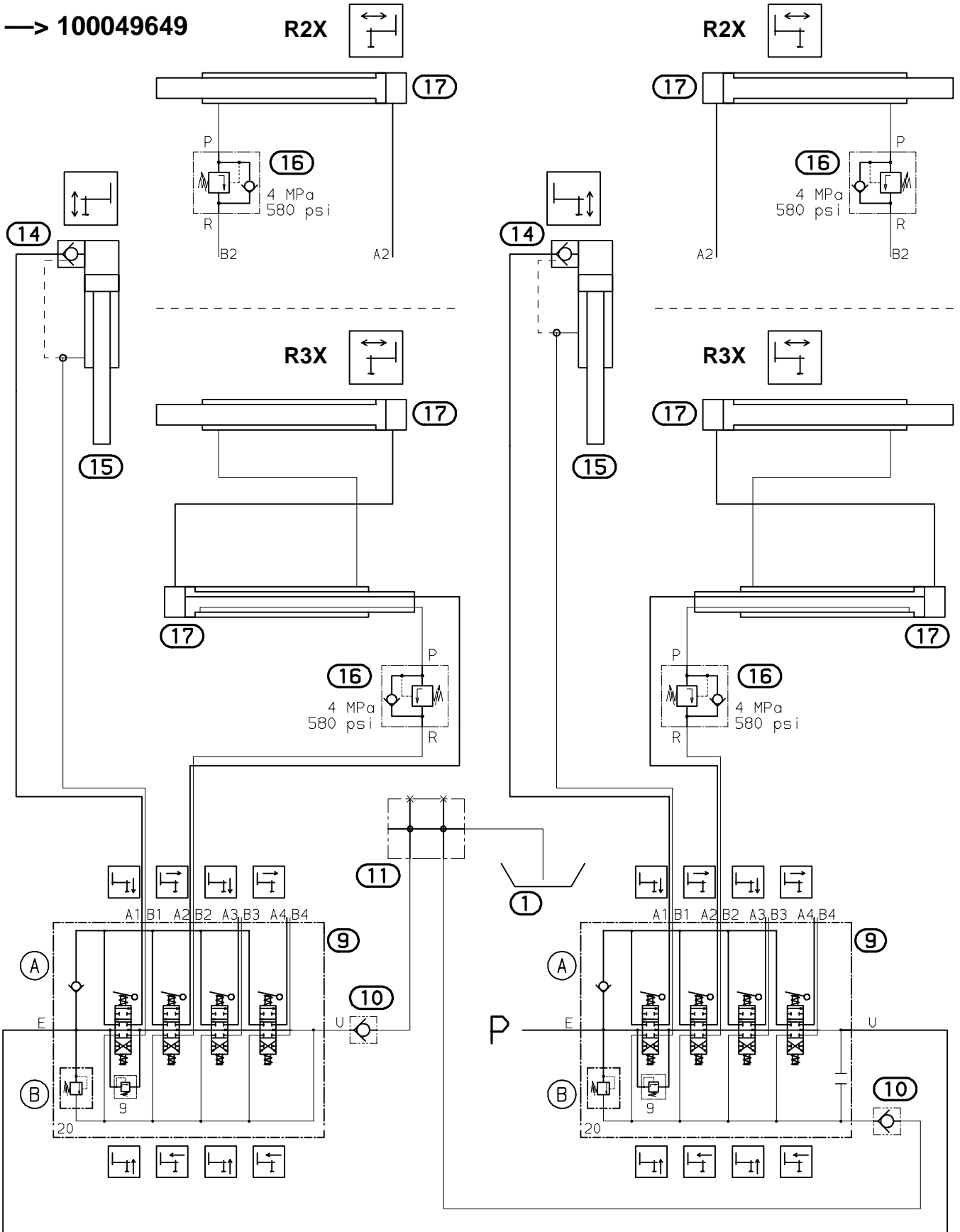

1 MPa = 10 bar = 145 psi

100049650 →

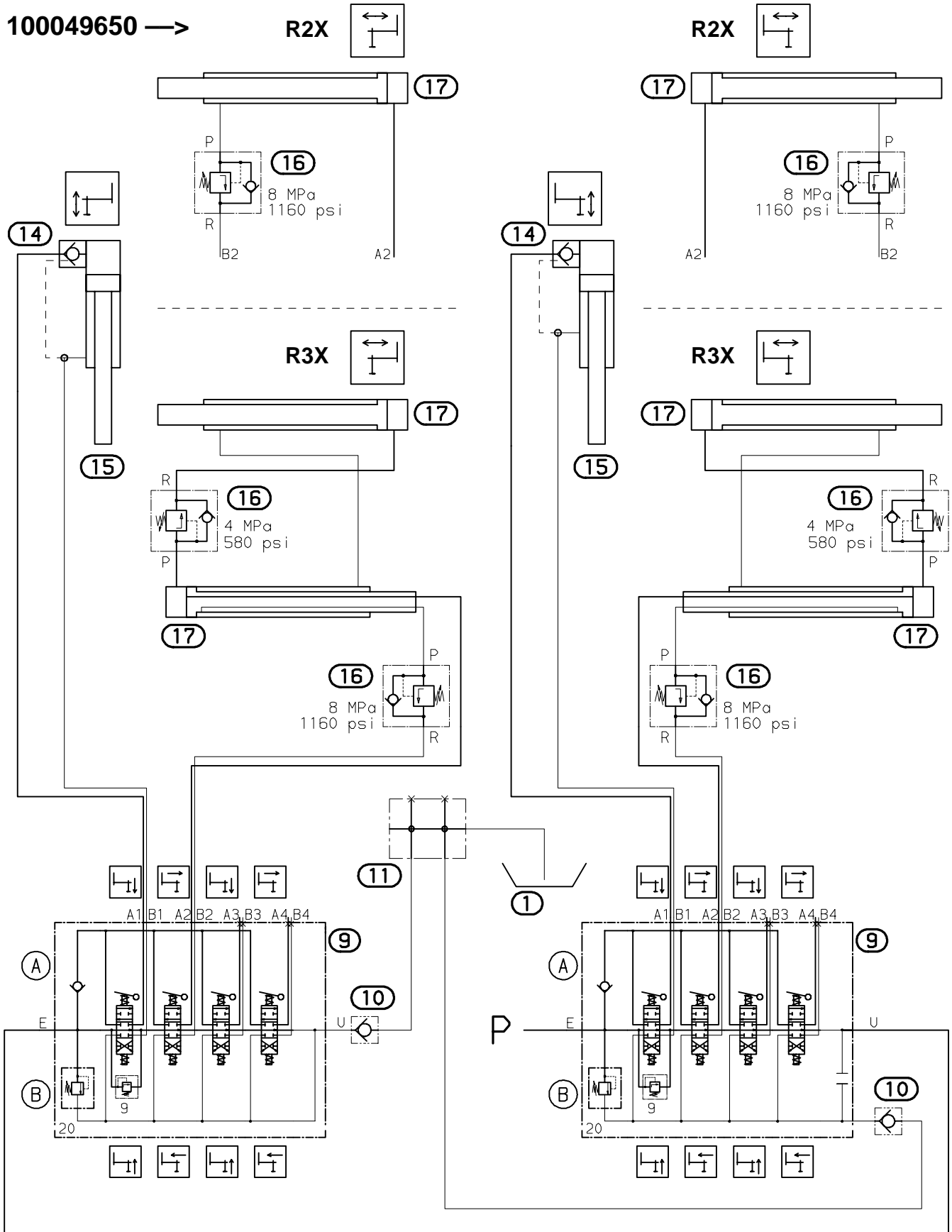

1 MPa = 10 bar = 145 psi

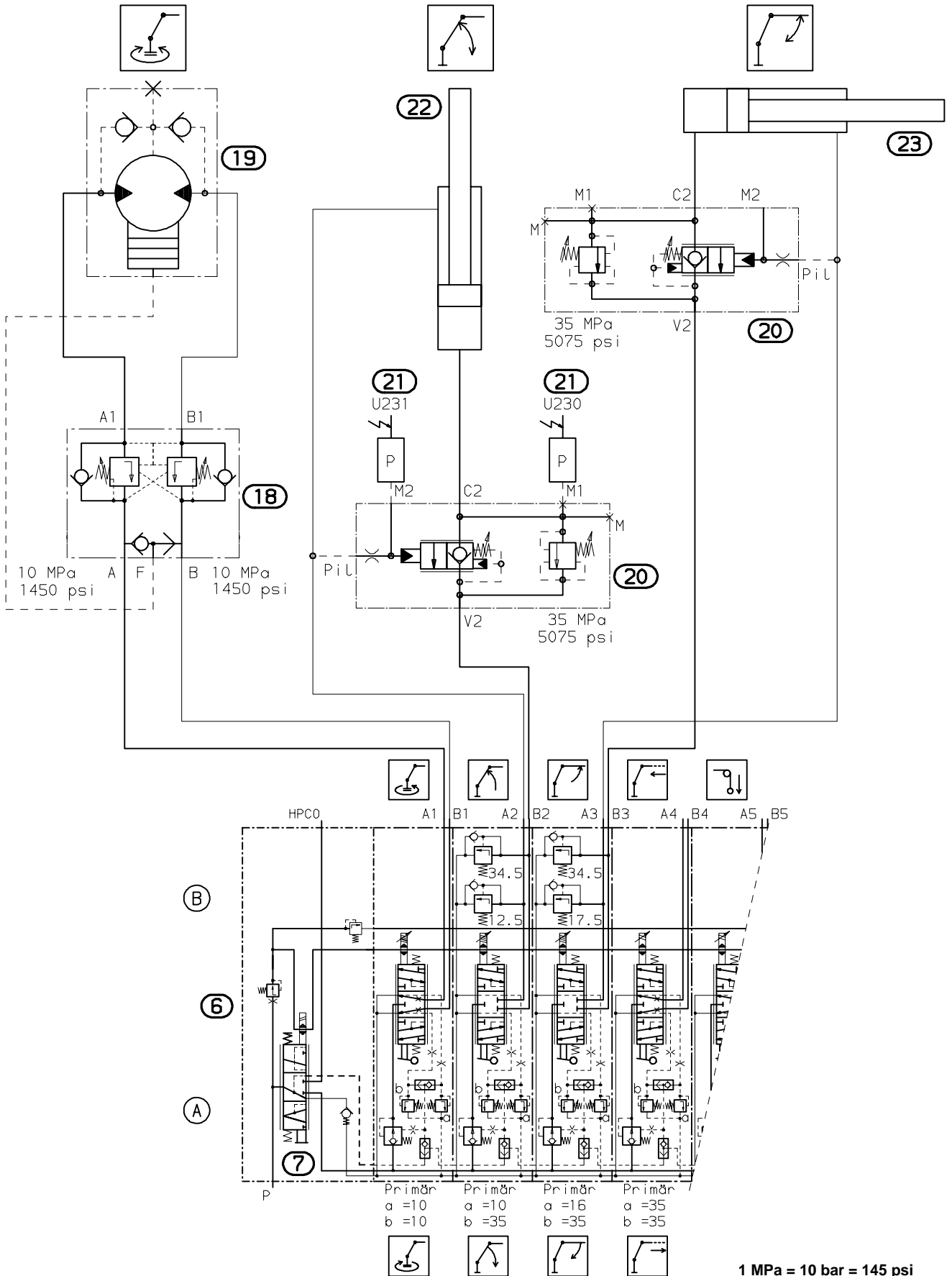

(→0746615)

**PK 36002 A –
 PK 36002 C**

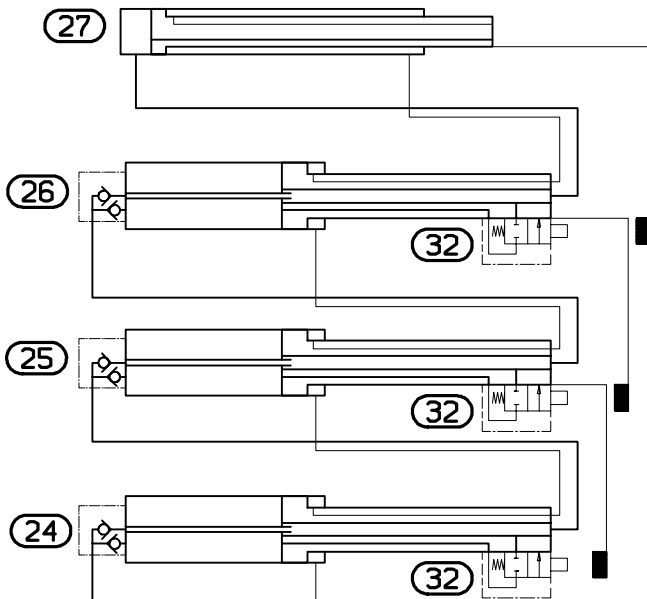

PK 36002 D

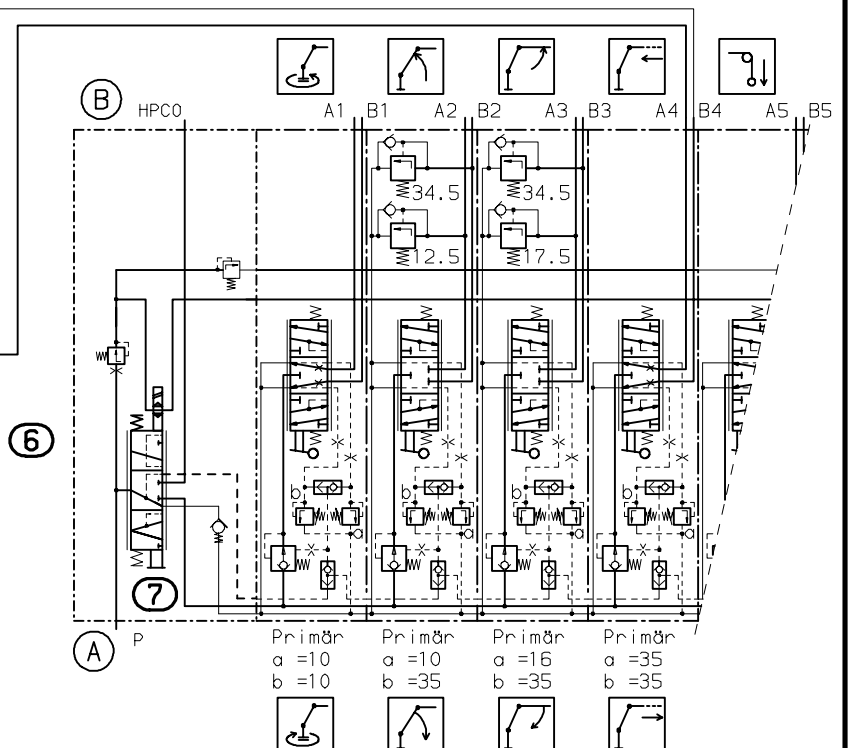
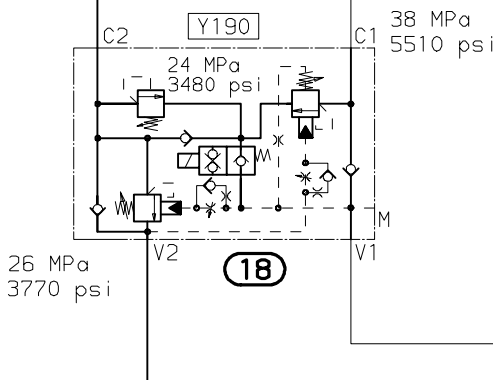
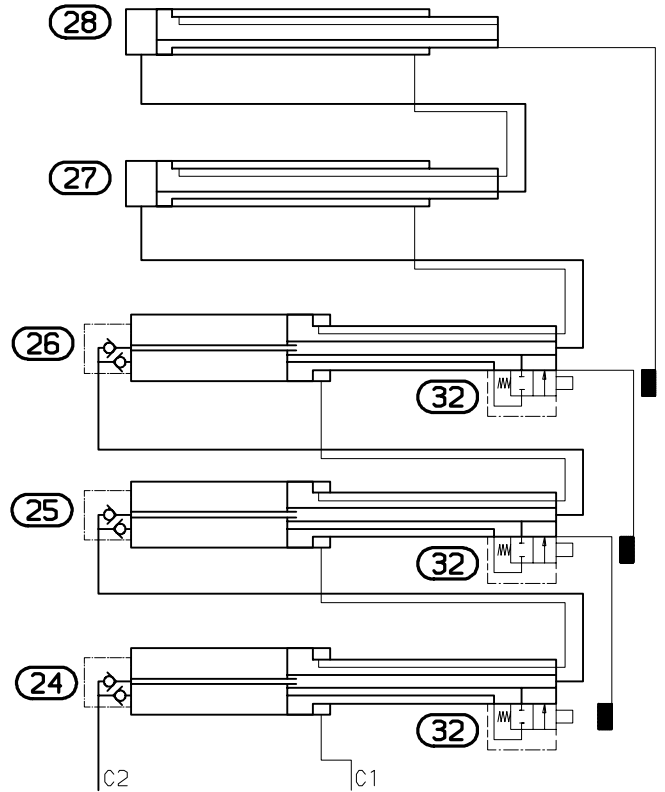

1 MPa = 10 bar = 145 psi

(0746616→)



**PK 36002 A –
 PK 36002 C**

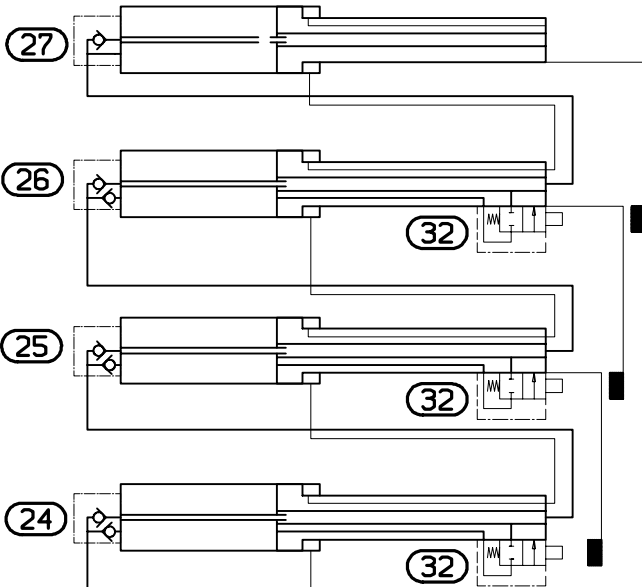

PK 36002 D

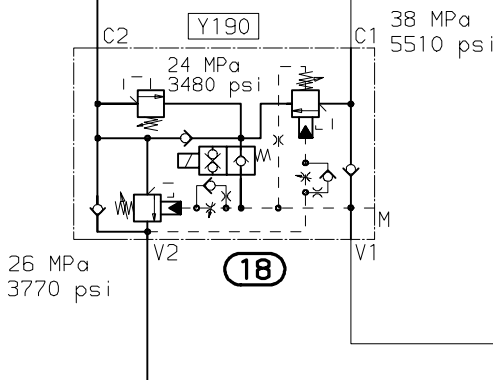
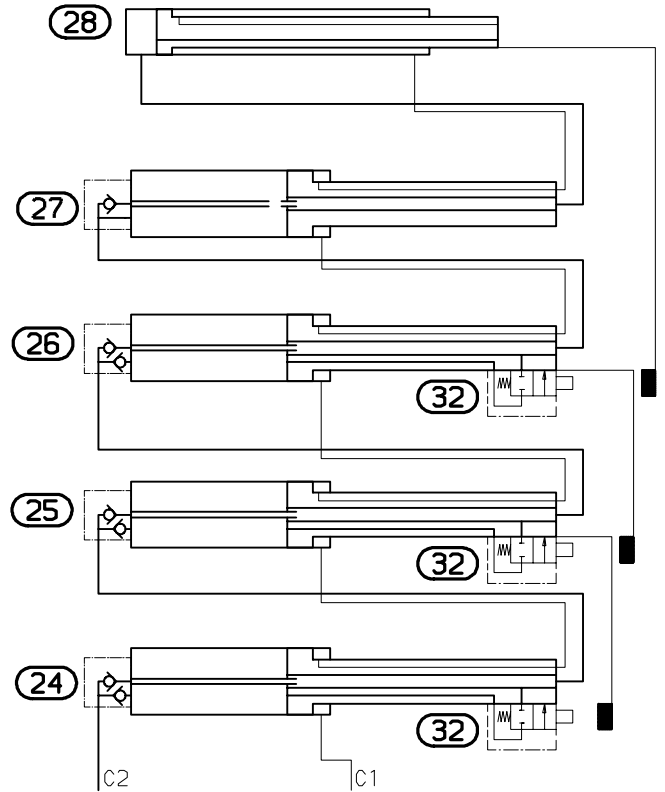

26 MPa
 3770 psi

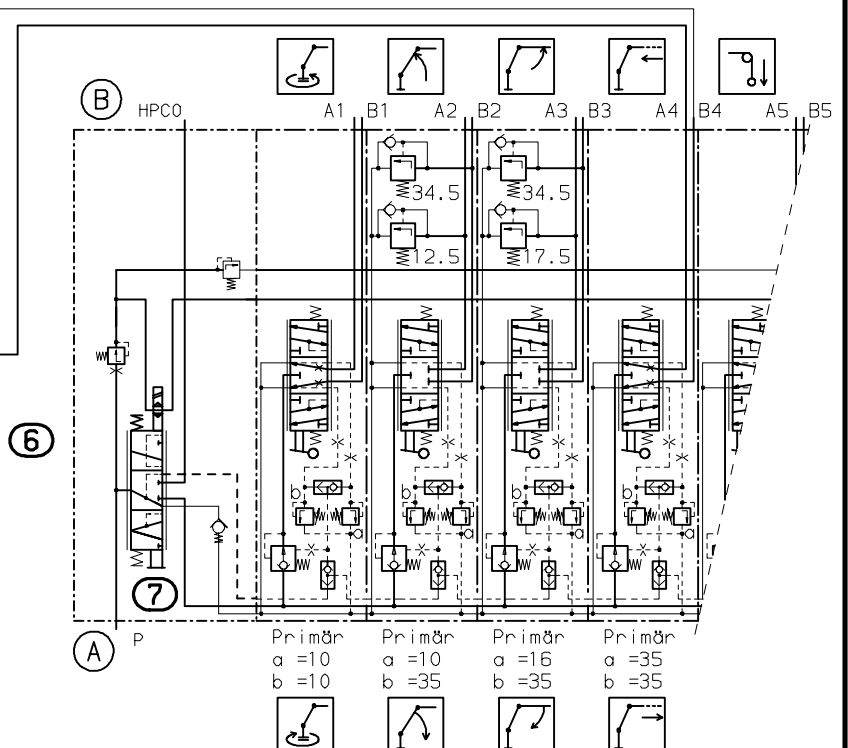

1 MPa = 10 bar = 145 psi

PK 36002 G

(—>0746615)



PK 36002 E

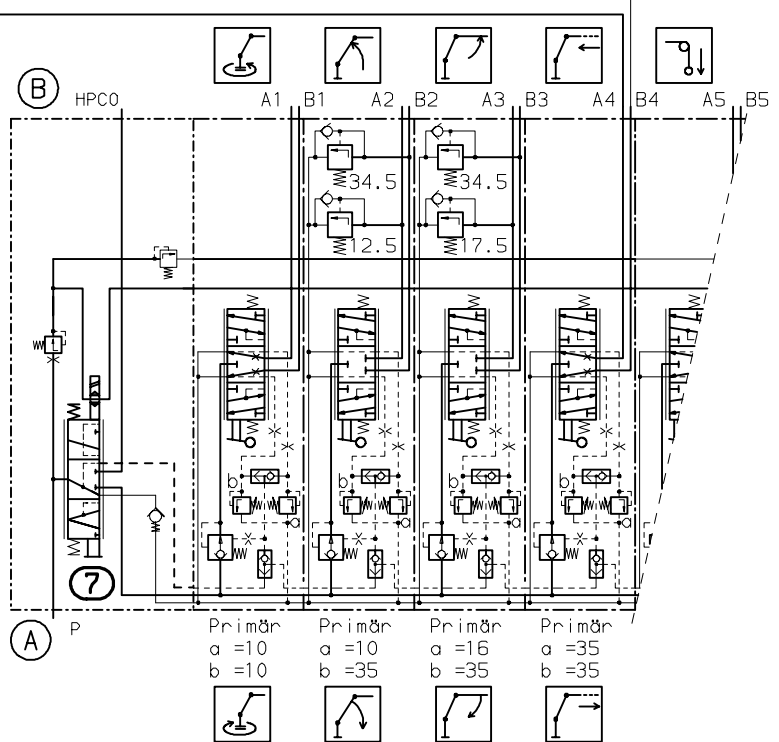
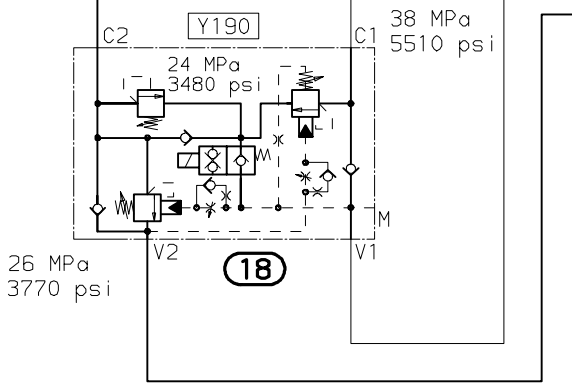
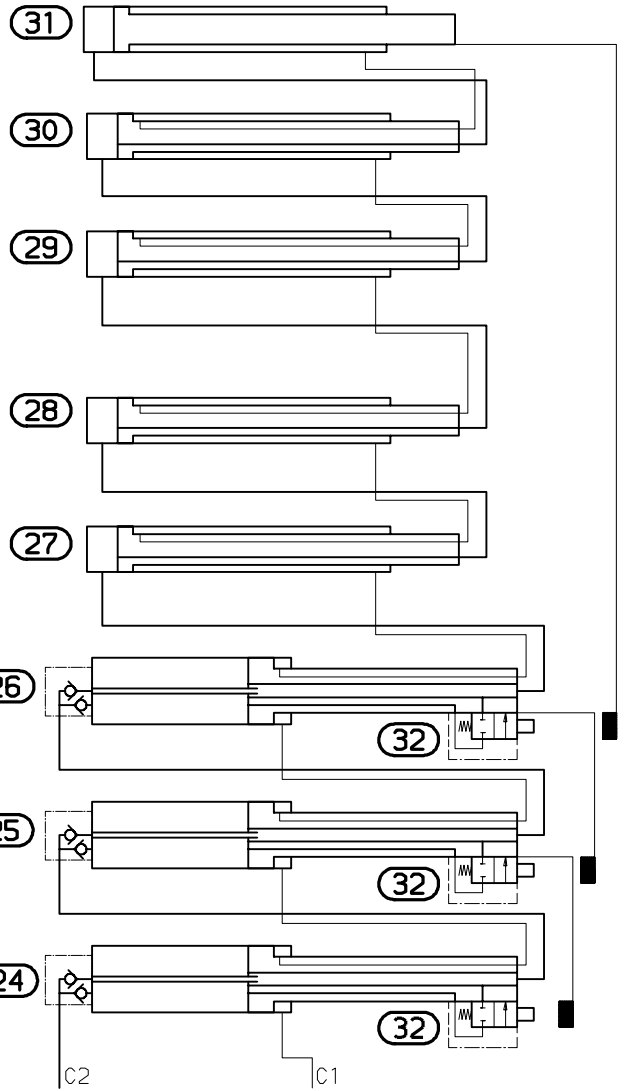
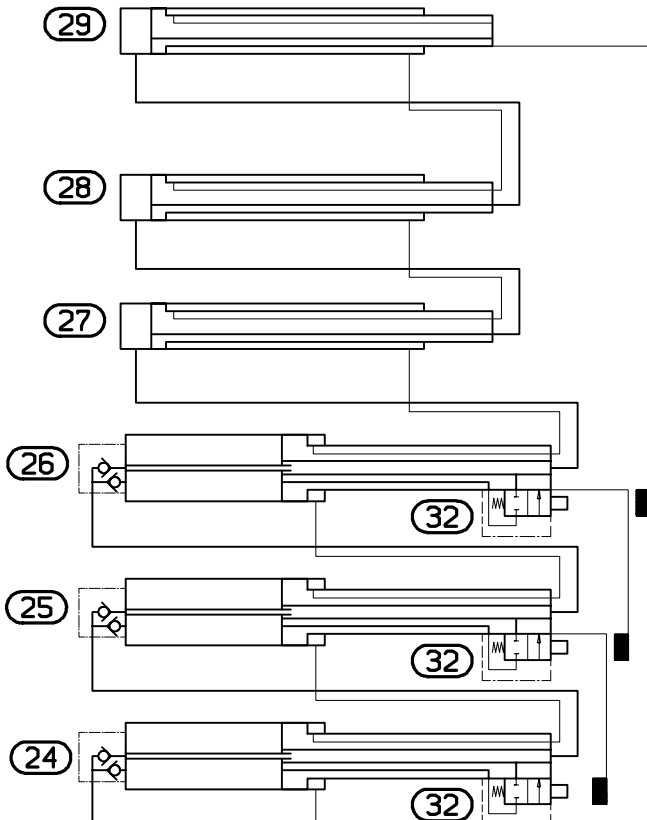

1 MPa = 10 bar = 145 psi

**PK 36002 F
 PK 36002 G**

(0746616 →)



PK 36002 E

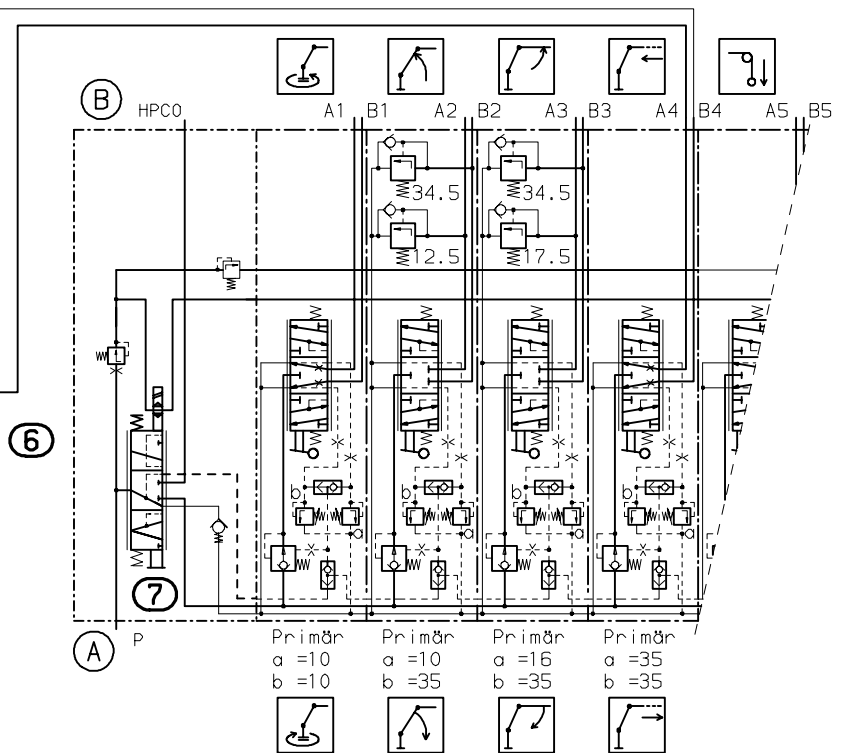
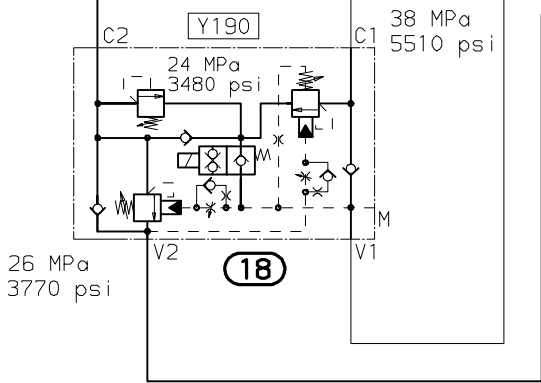
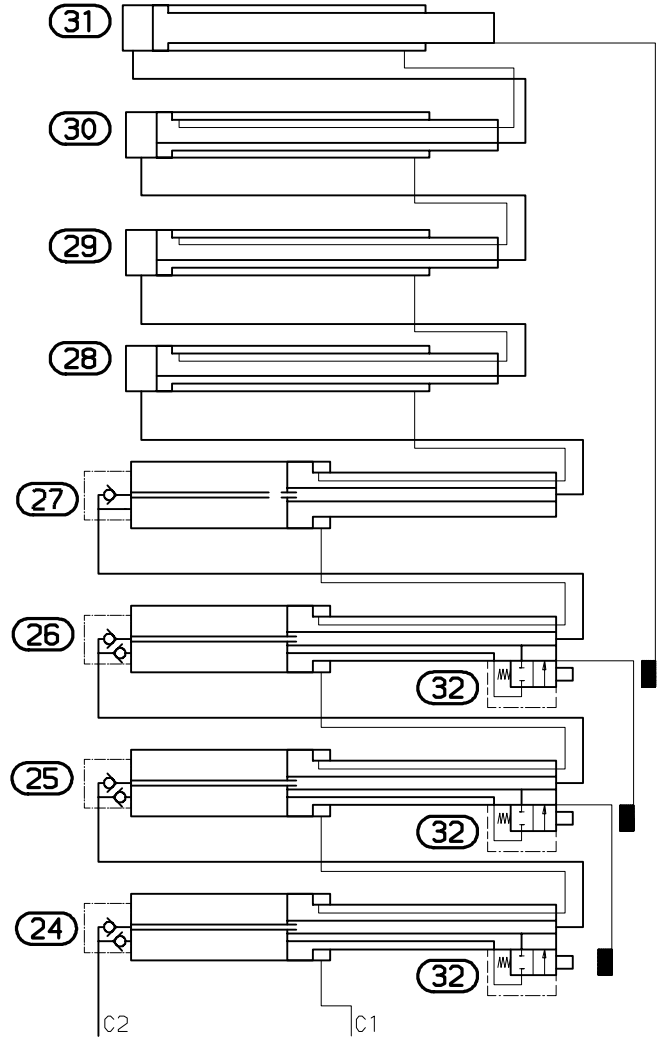
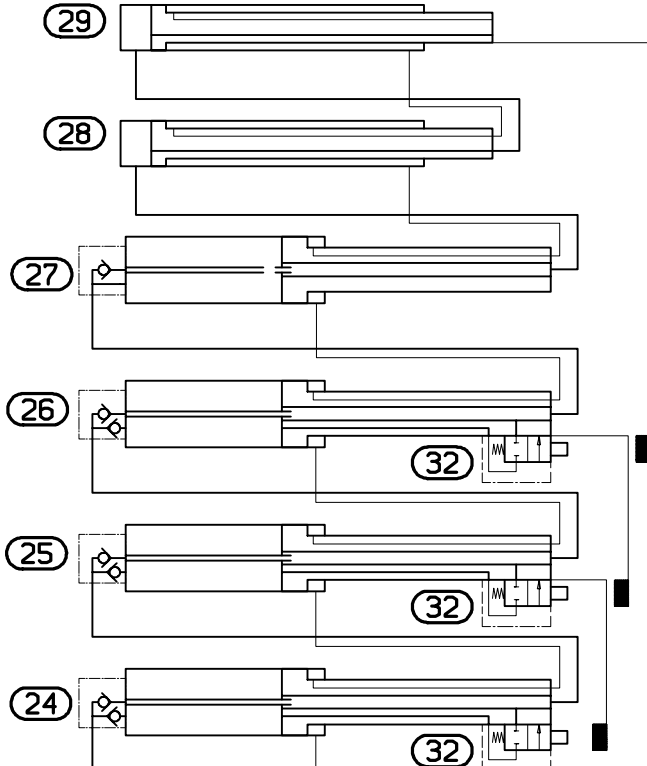

1 MPa = 10 bar = 145 psi

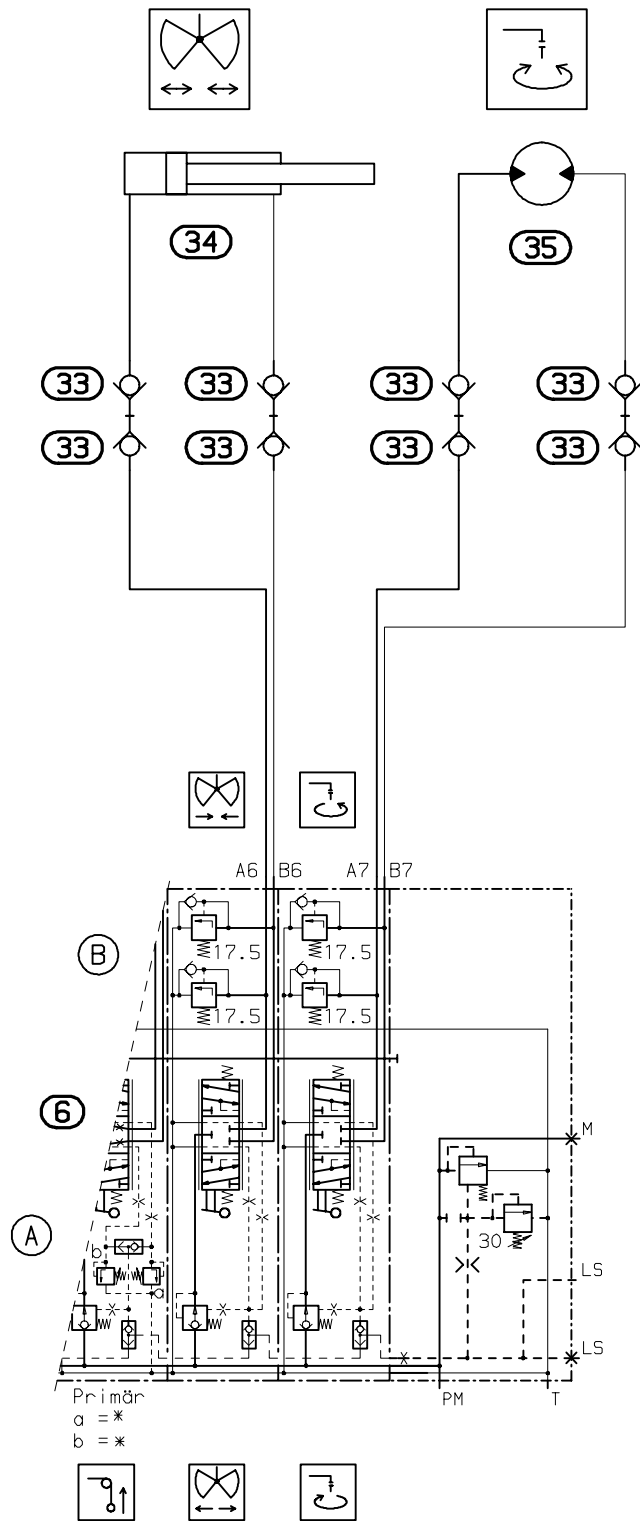

1 MPa = 10 bar = 145 psi

PJ085 B

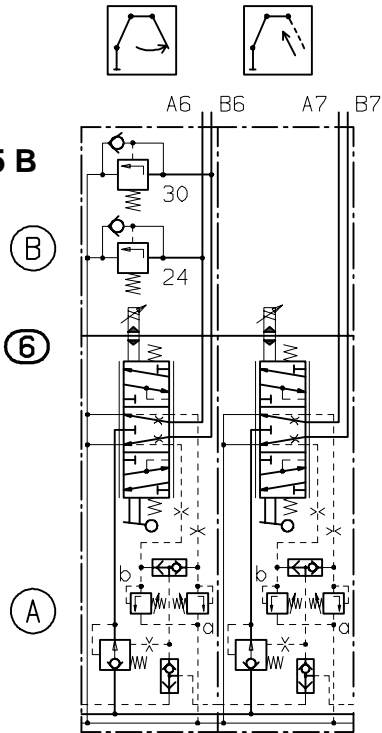

Primär Primär
 a = 21 a = 19
 b = 26.5 b = 25

PJ115 D

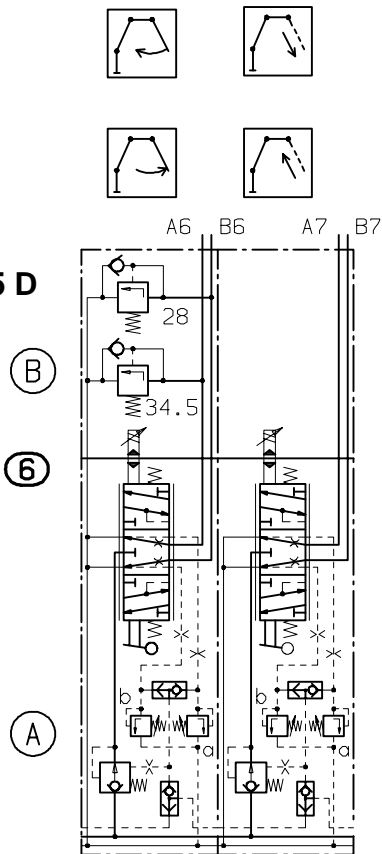

Primär Primär
 a = 35 a = 23
 b = 25 b = 35

1 MPa = 10 bar = 145 psi

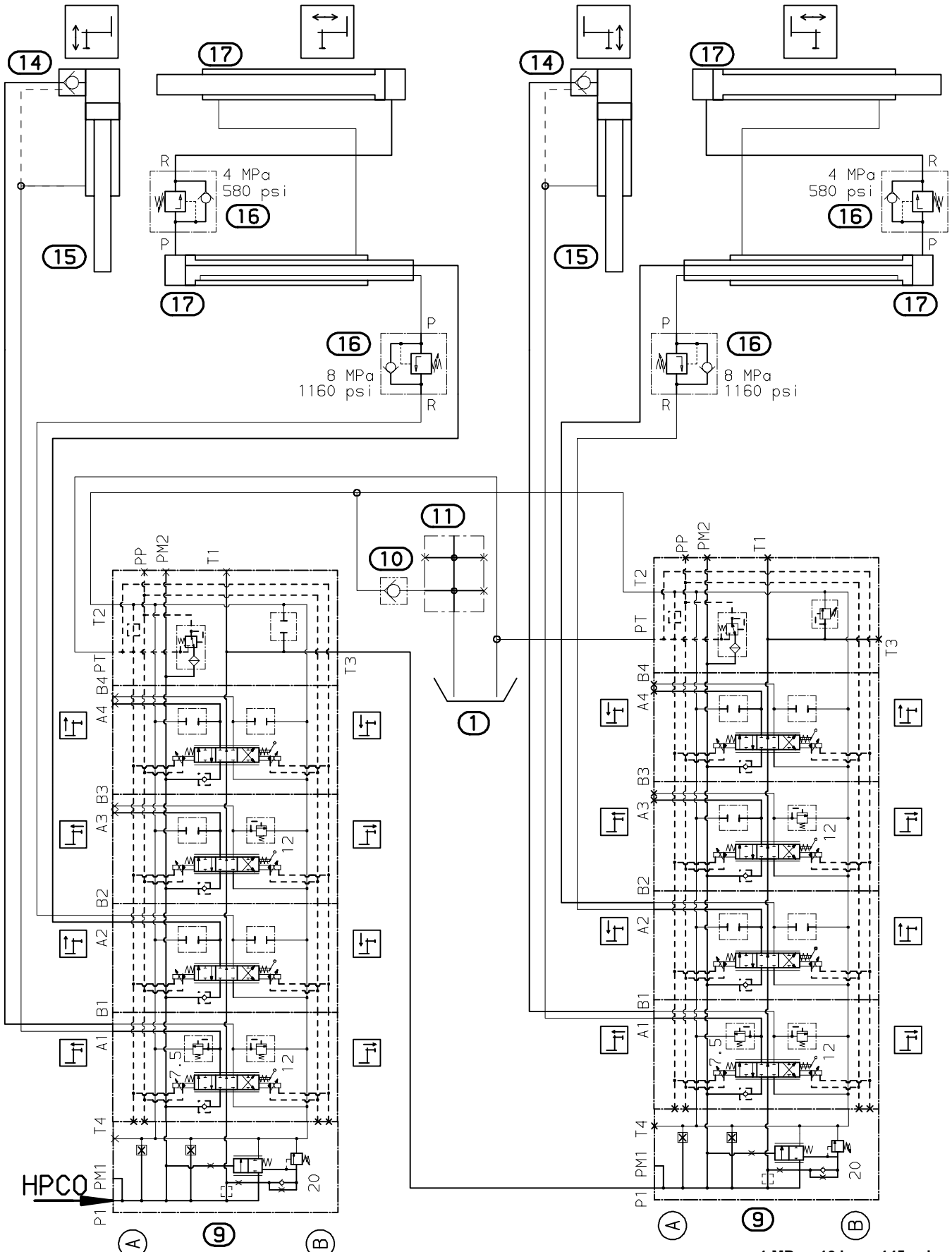

1 MPa = 10 bar = 145 psi

Modell Model Type
PK 36002
 SKES 22.9kN (2.3t)

PK 36002 C

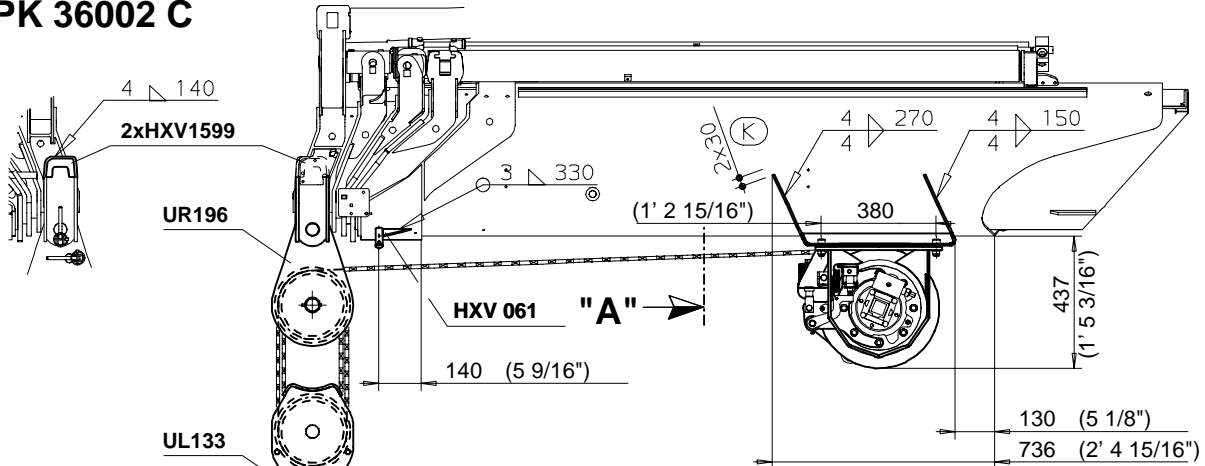

PK 36002 C

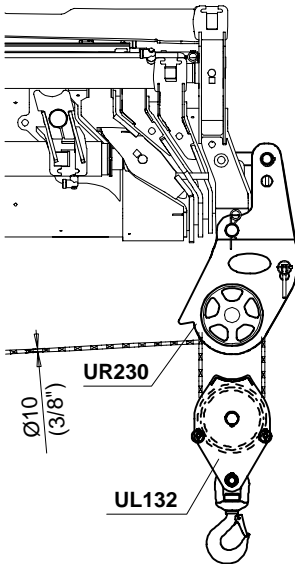

PK 36002 D - G

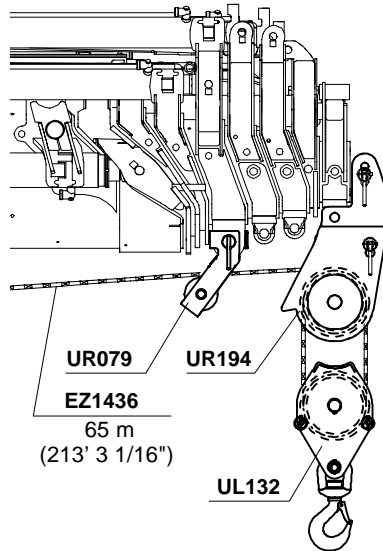

PK 36002 G + V

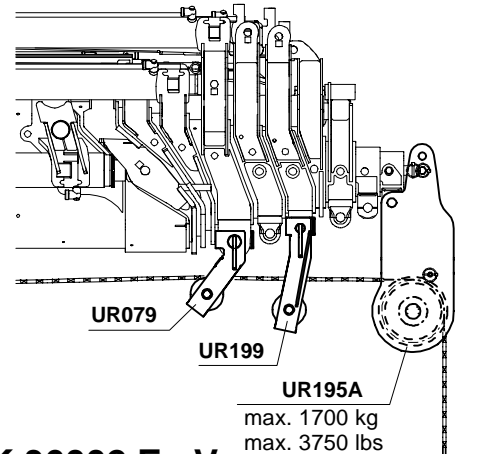

PK 36002 E + V

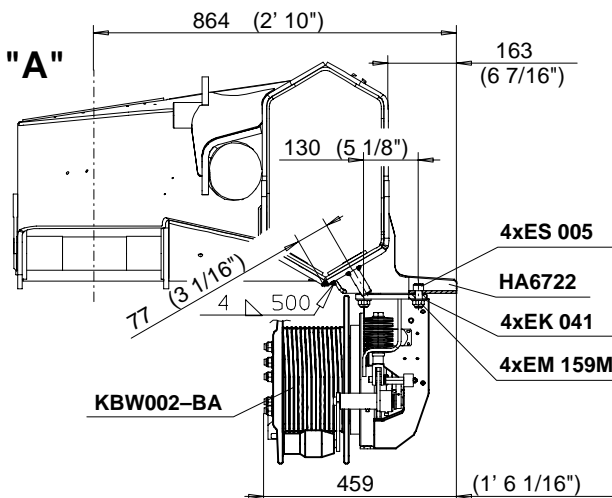
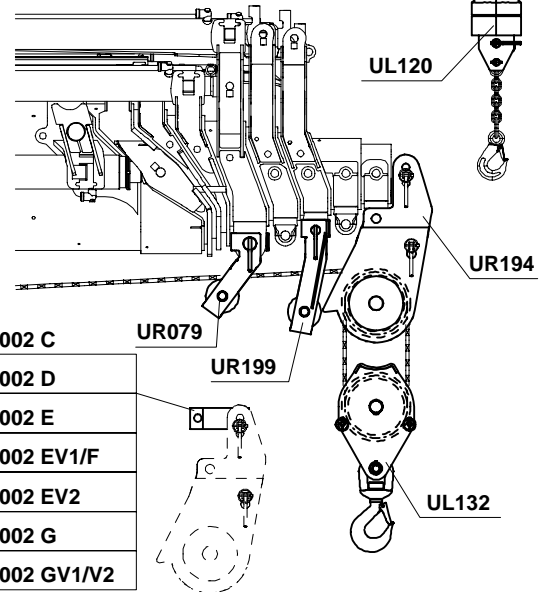

- 4xES 005 HHK 348→PK 36002 C
- HA6722 HHK 338→PK 36002 D
- 4xEK 041 HHK 339→PK 36002 E
- 4xEM 159M HHK 326→PK 36002 EV1/F
- KBW002-BA HHK 249→PK 36002 EV2
- HHK 249→PK 36002 G
- HHK 051→PK 36002 GV1/V2

KBW002-BA	EZ1436	HA6722	UR079	UR199	UR194	UR195A	UR196	UL120	UL132	UL133	UR230
105kg 231 lbs	33kg 73lbs	9kg 20lbs	4kg 9lbs	6kg 13lbs	30kg 66lbs	24kg 53lbs	47kg 104lbs	35kg 77lbs	36kg 79lbs	66kg 146lbs	39kg 90lbs

Modell Model Type
PK 36002
 SKES 32.2kN (3.2t)

PK 36002 C

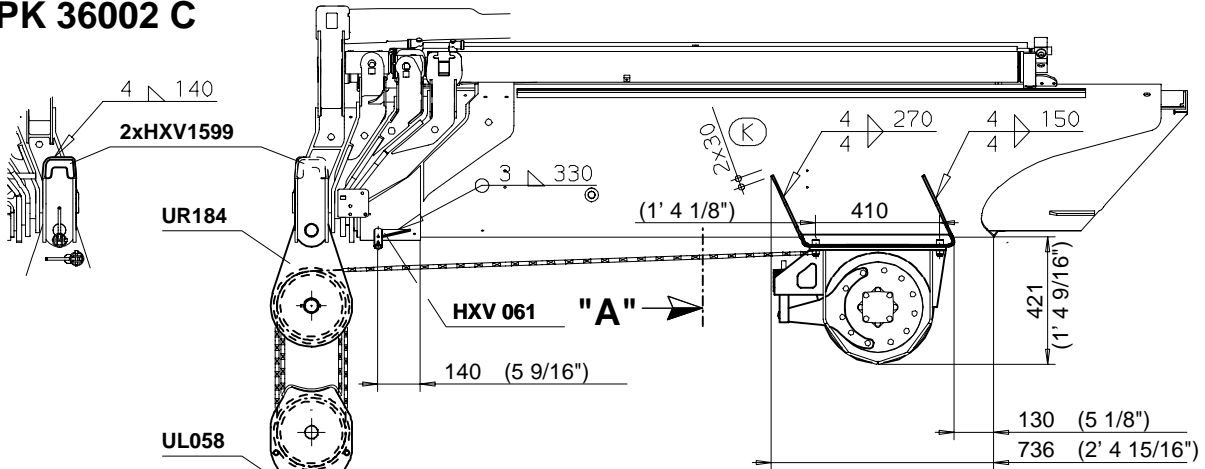

PK 36002 C

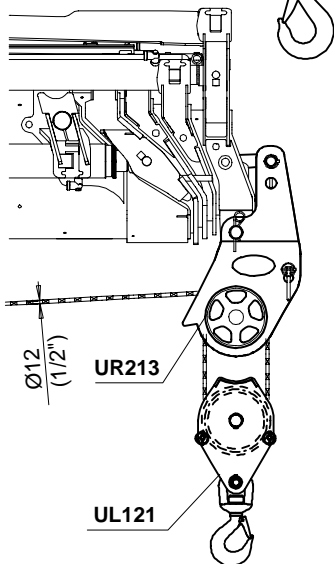

PK 36002 D - G

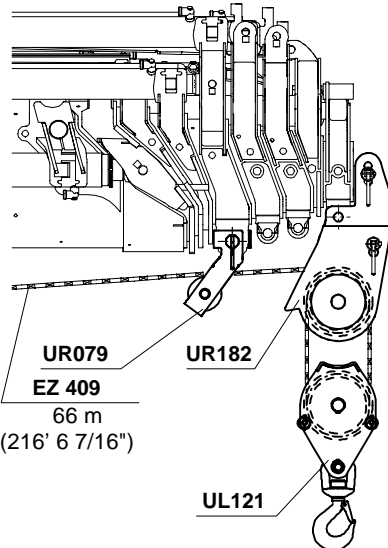

PK 36002 G + V

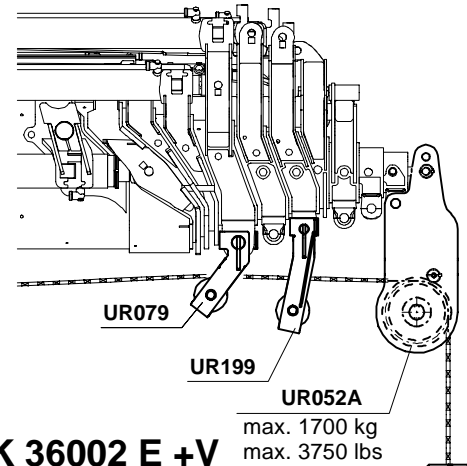

PK 36002 E + V

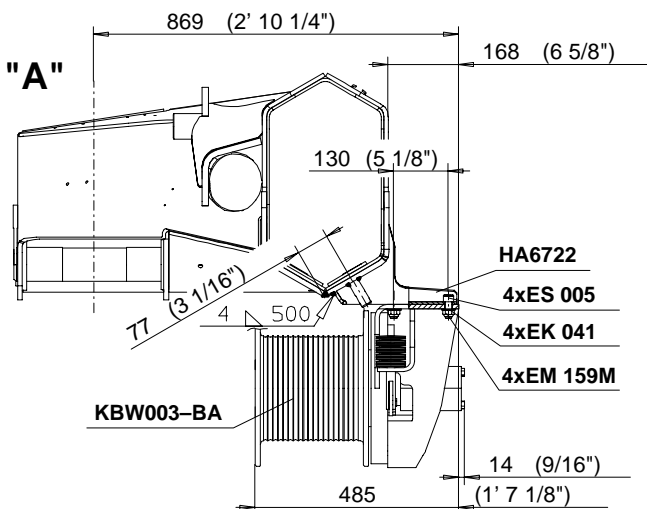
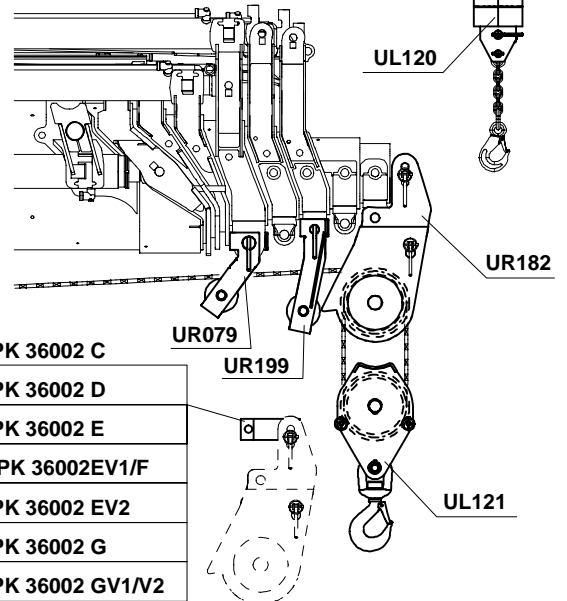

- HHK 348 → PK 36002 C
- HHK 338 → PK 36002 D
- HHK 339 → PK 36002 E
- HHK 326 → PK 36002EV1/F
- HHK 249 → PK 36002 EV2
- HHK 249 → PK 36002 G
- HHK 051 → PK 36002 GV1/V2

KBW003-BA	EZ 409	HA6722	UR079	UR199	UR182	UR052A	UR184	UL120	UL121	UL058	UR213
155kg 342lbs	45kg 90lbs	9kg 20lbs	4kg 9lbs	6kg 13lbs	30kg 66lbs	24kg 53lbs	47kg 104lbs	35kg 77lbs	36kg 79lbs	66kg 146lbs	50kg 110lbs

PK 36002 C – PJ 115 D

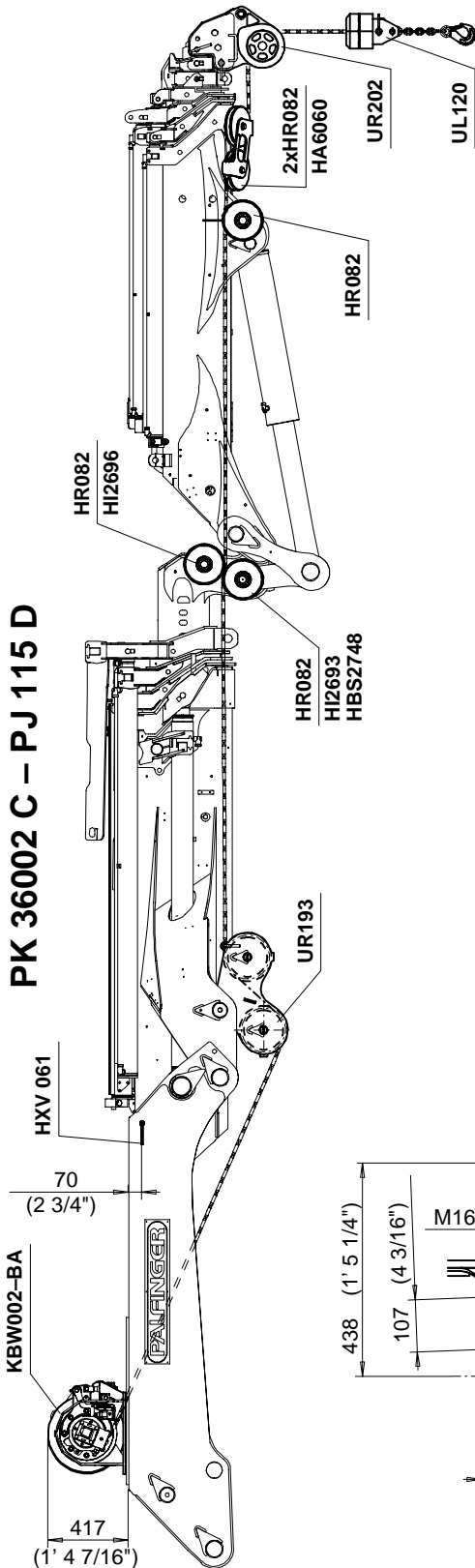

PJ 115 D

max. 3150 kg
max. 6950 lbs

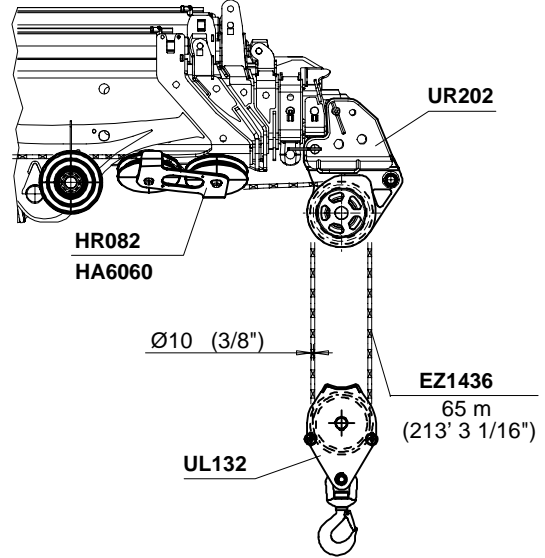

A	max. 3150 kg max. 6950 lbs
B	max. 2200 kg max. 4850 lbs
C	max. 600 kg max. 1323 lbs

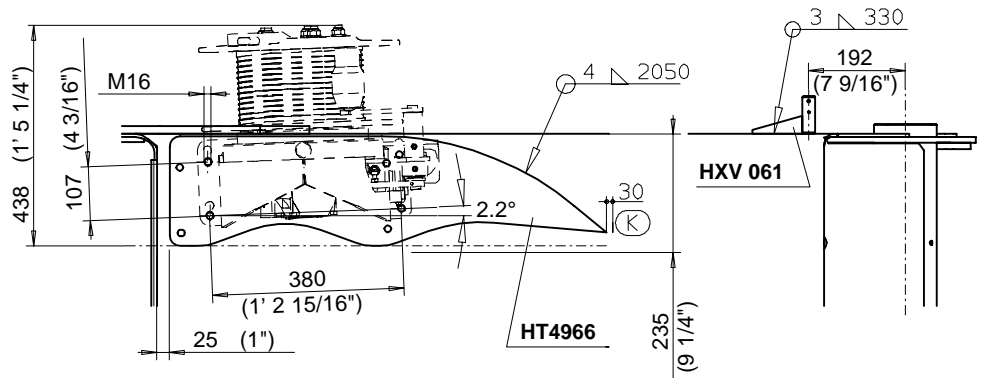
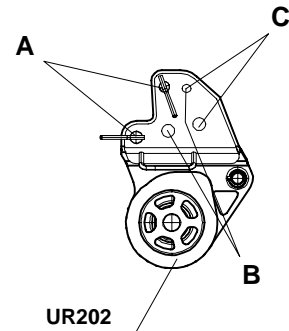

KBW002-BA	EZ1436	HT4966	UR193	HR082	HA6060	UR202	UL120	UL132
105kg 231 lbs	33kg 73 lbs	16kg 35 lbs	29kg 64 lbs	5kg 11 lbs	2kg 4 lbs	27kg 60 lbs	35kg 77 lbs	36kg 79 lbs
C PJ 115 D	C PJ 115 D	C	C	PJ 115 D	PJ 115 D	PJ 115 D	C PJ 115 D	C PJ 115 D

PK 36002 D – PJ085 B

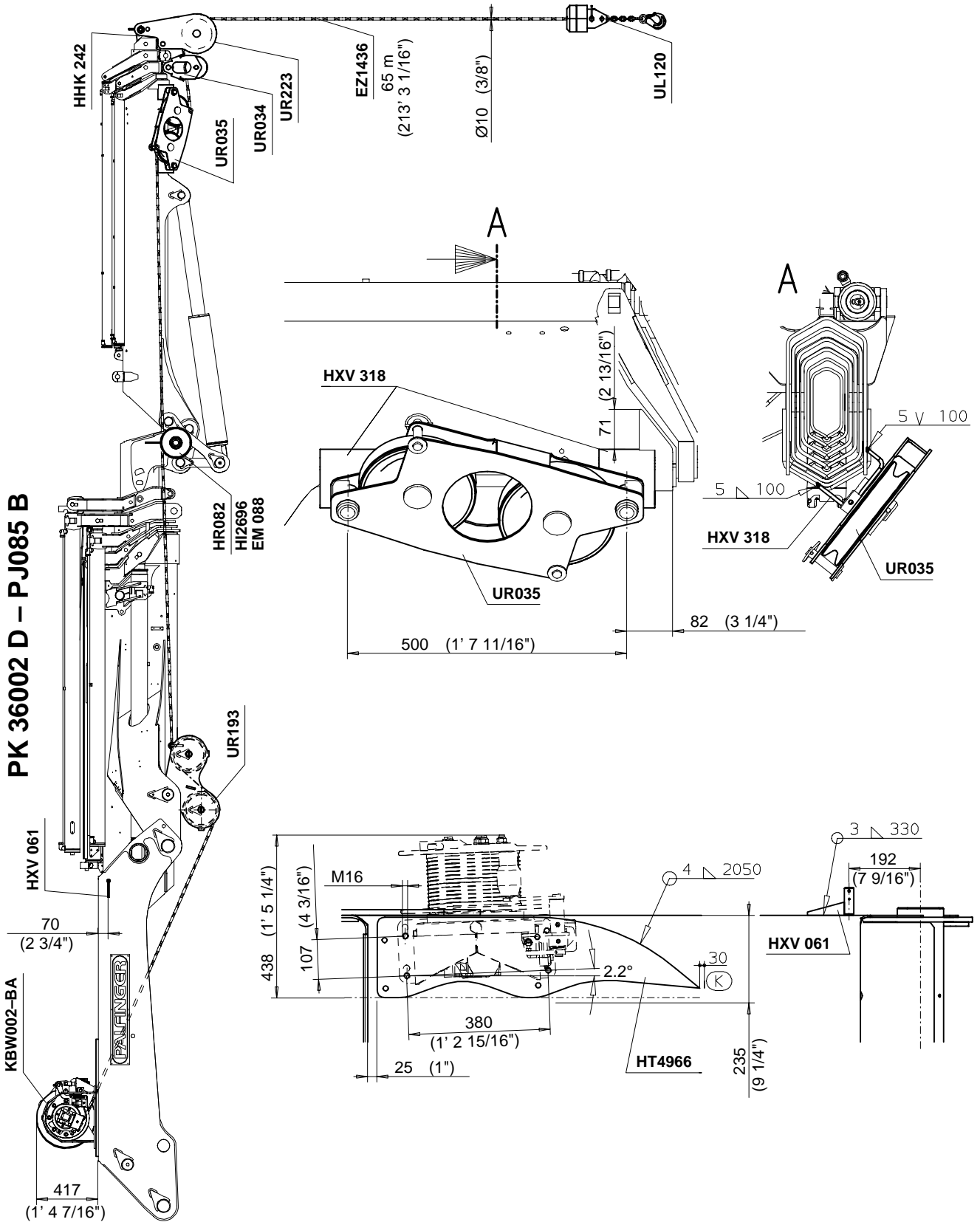

KBW002-BA	EZ1436	HT4966	UR193	HR082	UR035	UR034	UL120	UR223
105kg 231 lbs	33kg 73 lbs	16kg 35 lbs	29kg 64 lbs	5kg 11 lbs	16kg 35 lbs	6kg 13 lbs	35kg 77 lbs	26kg 57 lbs
D PJ085 B	D PJ085 B	D	D	PJ085 B	PJ085 B	PJ085 B	D PJ085 B	D PJ085 B

PK 36002 C

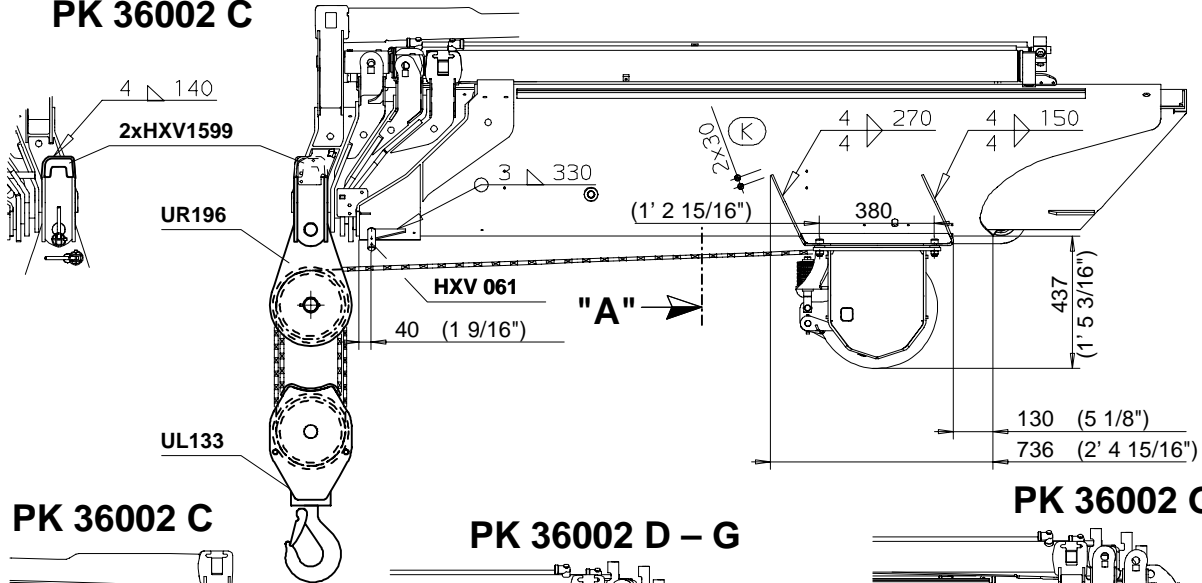

PK 36002 C

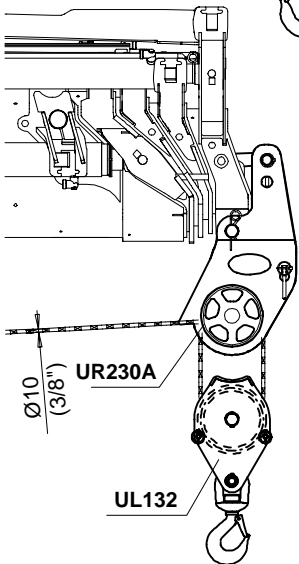

PK 36002 D - G

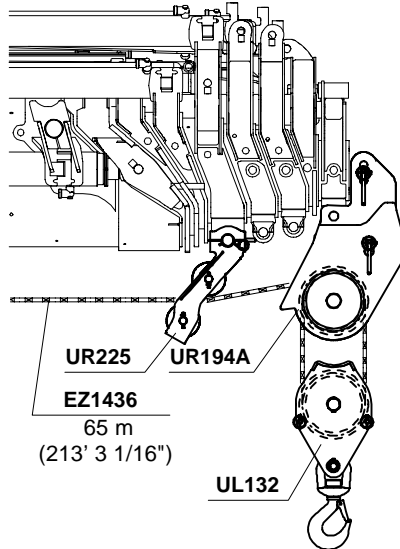

PK 36002 G + V

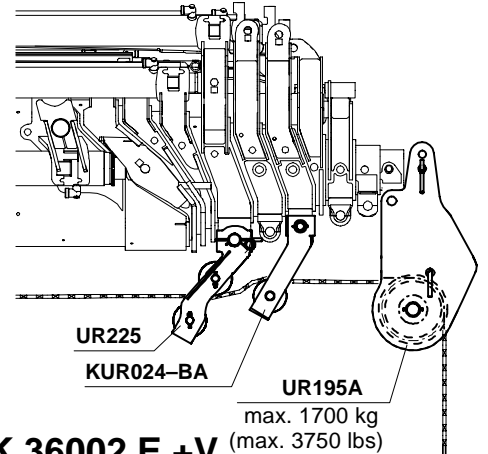

PK 36002 E + V

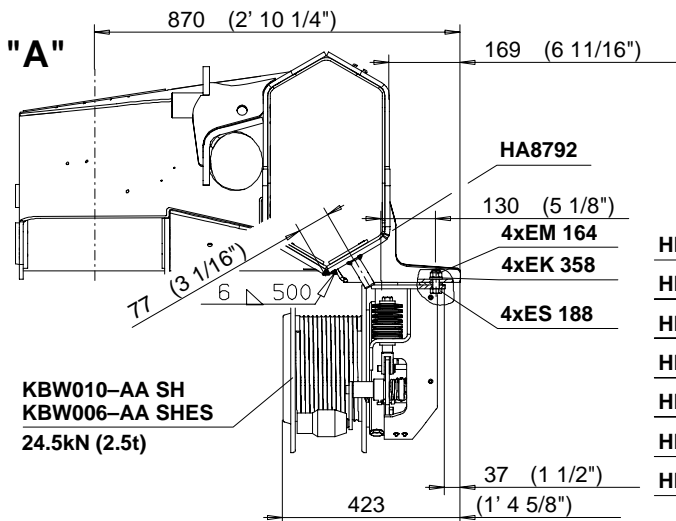
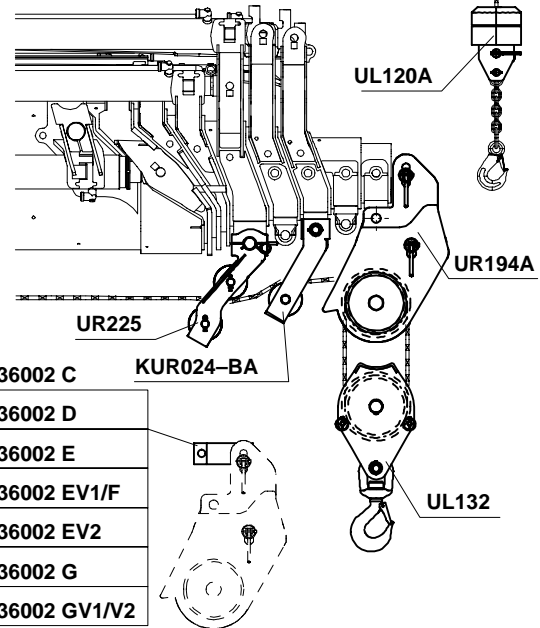

- HHK 348 → PK 36002 C
- HHK 338 → PK 36002 D
- HHK 339 → PK 36002 E
- HHK 326 → PK 36002 EV1/F
- HHK 249 → PK 36002 EV2
- HHK 249 → PK 36002 G
- HHK 051 → PK 36002 GV1/V2

KBW006-AA	KBW010-AA	EZ1436	HA8792	UR225	KUR024-BA	UR194A	UR195A	UR196	UL120A	UL132	UL133	UR230A
105 kg (231 lbs)	85 kg (187 lbs)	30 kg (66 lbs)	9 kg (20 lbs)	7 kg (15 lbs)	5 kg (11 lbs)	32 kg (71 lbs)	28 kg (62 lbs)	47 kg (104 lbs)	35 kg (77 lbs)	36 kg (79 lbs)	66 kg (146 lbs)	39 kg (86 lbs)

PK 36002 C

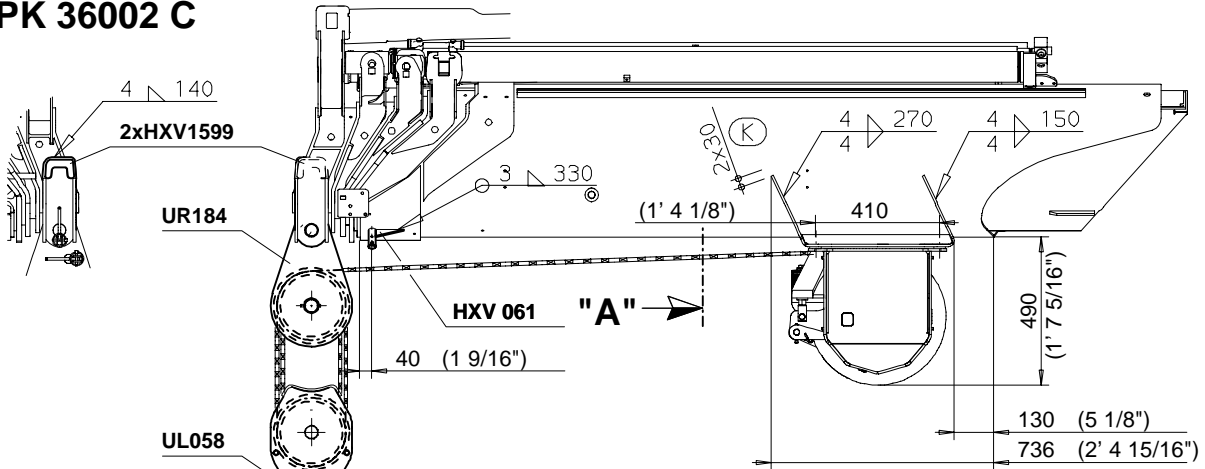

PK 36002 C

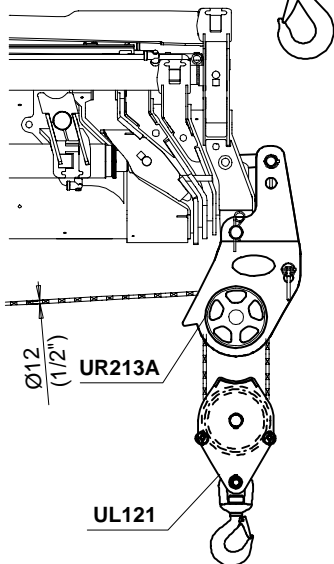

PK 36002 D - G

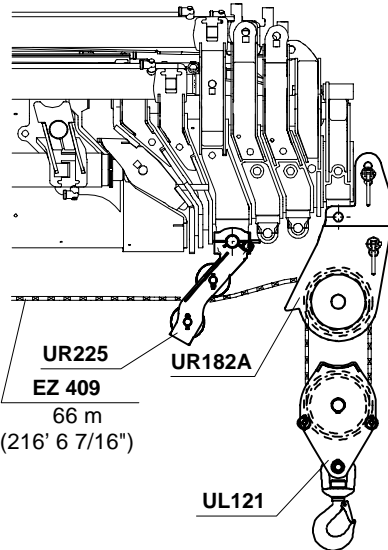

PK 36002 G + V

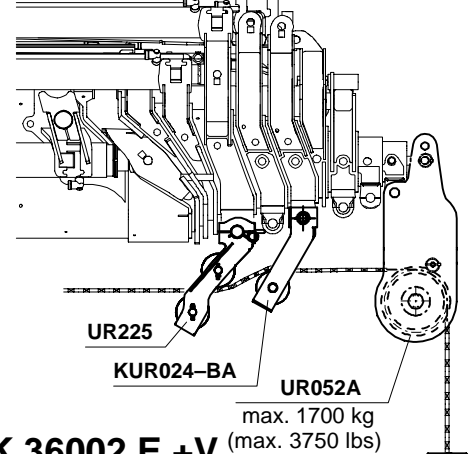

PK 36002 E + V

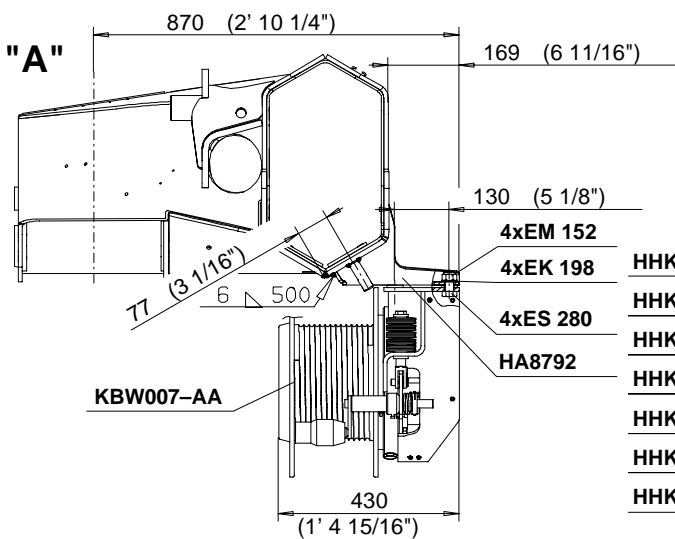
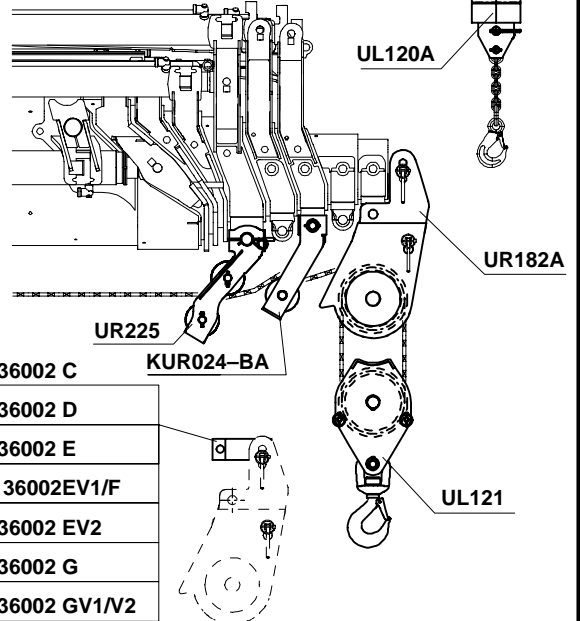

- HHK 348 → PK 36002 C
- HHK 338 → PK 36002 D
- HHK 339 → PK 36002 E
- HHK 326 → PK 36002EV1/F
- HHK 249 → PK 36002 EV2
- HHK 249 → PK 36002 G
- HHK 051 → PK 36002 GV1/V2

KBW007-AA	EZ 409	HA8792	UR225	KUR024-BA	UR182A	UR052A	UR184	UL120A	UL121	UL058	UR213A
150kg 331 lbs	45kg 90lbs	9kg 20lbs	7kg 15lbs	5kg 11lbs	30kg 66lbs	24kg 53lbs	47kg 104lbs	35kg 77lbs	36kg 79lbs	66kg 146lbs	50kg 110lbs

Konstruktionsänderungen vorbehalten, fertigungstechn. Toleranzen müssen berücksichtigt werden.
 Subject to change, production tolerances have to be taken into account.
 Sous réserve de modifications de conception, Les tolérances relatives à la technique de production doivent être prises en considération.

KBW010-AA SH
 KBW006-AA SHES
 24.5kN (2.5t)

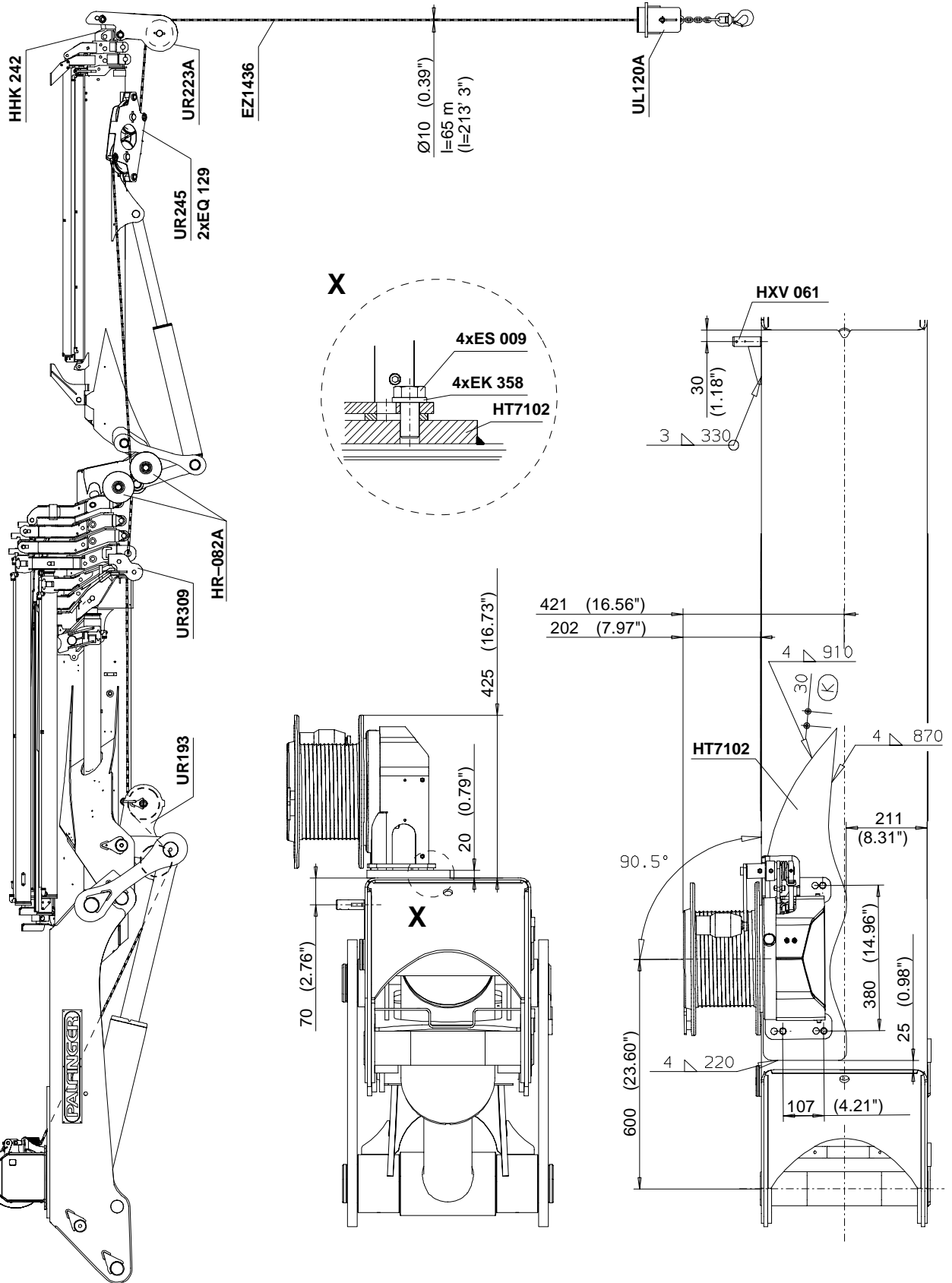

KBW006-AA SHES	KBW010-AA SH	HT7102	UR309	UR193	UR245	HXV 061	UR223A	HR 082A	UL120A	HHK 242	EZ1436
105 kg (231 lbs)	85 kg (187 lbs)	21 kg (46 lbs)	4 kg (9 lbs)	29 kg (64 lbs)	18 kg (40 lbs)	0.5 kg (1 lbs)	23 kg (51 lbs)	4.2kg (9 lbs)	35 kg (77 lbs)	5 kg (11 lbs)	30 kg (66 lbs)

Konstruktionsänderungen vorbehalten, fertigungstechn. Toleranzen müssen berücksichtigt werden.
 Subject to change, production tolerances have to be taken into account.
 Sous réserve de modifications de conception, Les tolérances relatives à la technique de production doivent être prises en considération.

KBW010-AA SH
 KBW006-AA SHES
 24.5kN (2.5t)

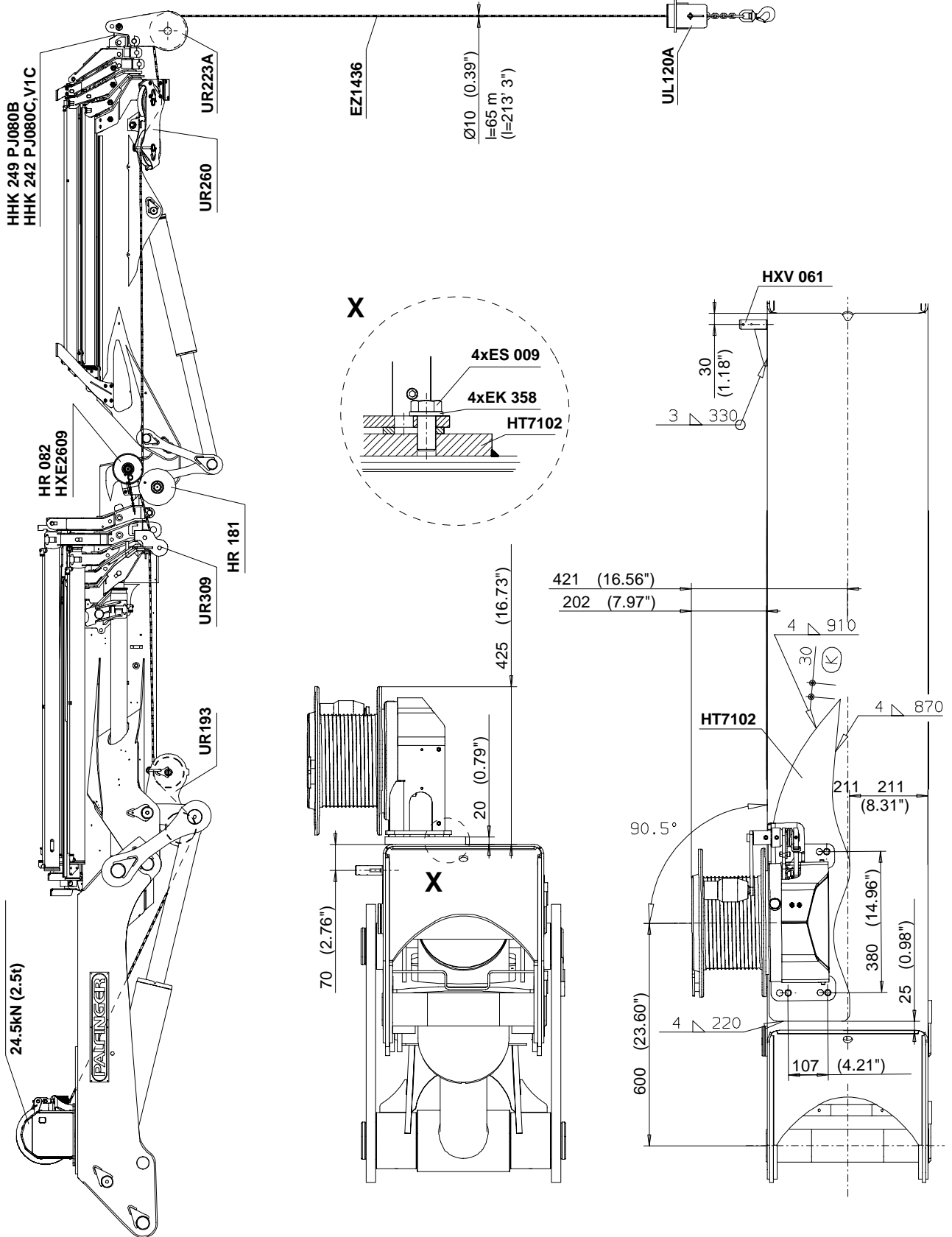

KBW006-AA SHES	KBW010-AA SH	HT7102	UR309	UR193	UR260	HXV 061	UL120A	HR 082 HR 181 HXE2609	HHK 249 HHK 242	UR223A	EZ1436
105 kg (231 lbs)	85 kg (187 lbs)	21 kg (46 lbs)	4 kg (9 lbs)	29 kg (64 lbs)	28 kg (62 lbs)	0.5 kg (1 lbs)	35 kg (77 lbs)	15 kg (33 lbs)	4 kg (9 lbs)	22 kg (49 lbs)	30 kg (66 lbs)

Konstruktionsänderungen vorbehalten, fertigungstechn. Toleranzen müssen berücksichtigt werden.
 Subject to change, production tolerances have to be taken into account.
 Sous réserve de modifications de conception. Les tolérances relatives à la technique de production doivent être prises en considération.

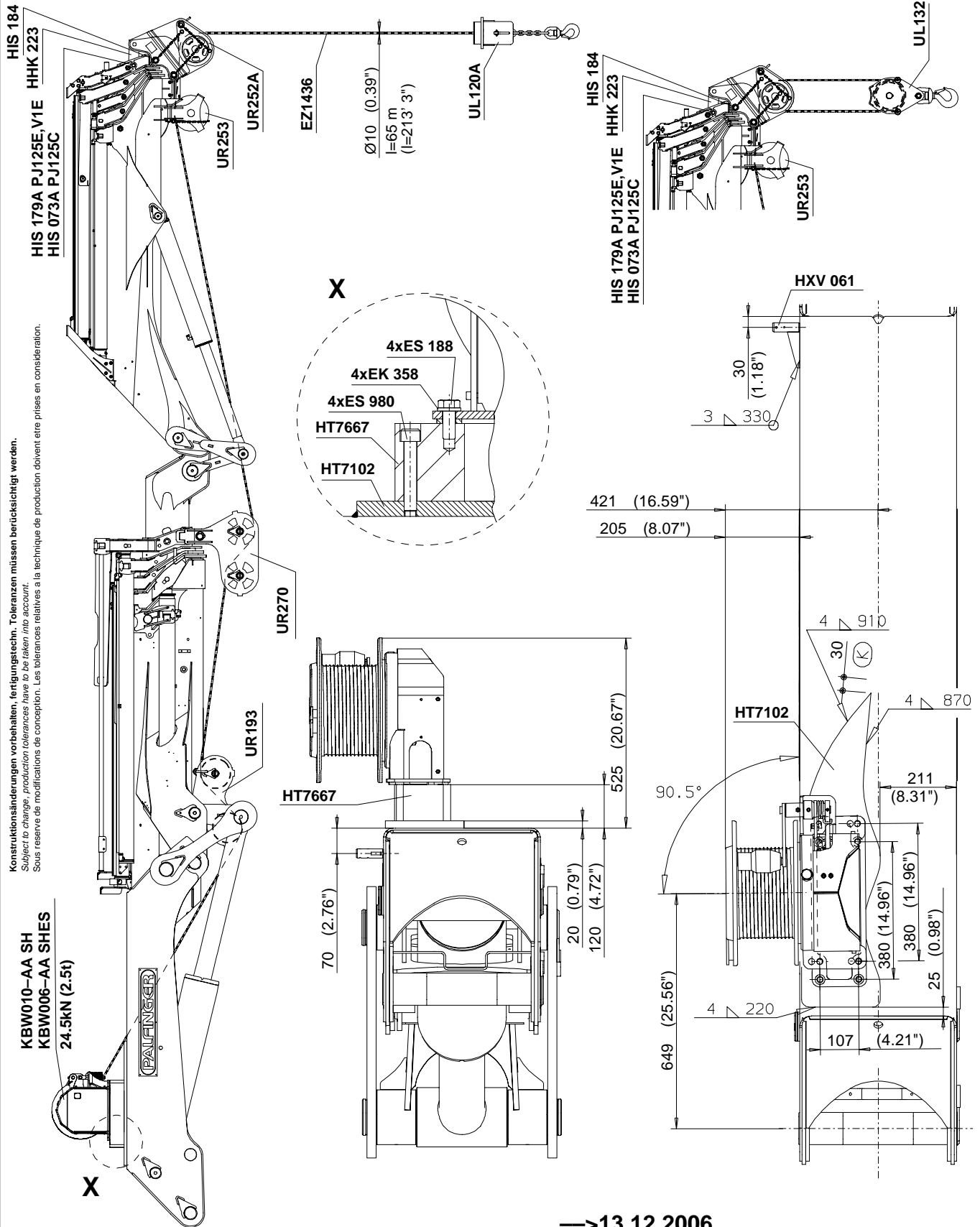

→13.12.2006

KBW006-AA SHES	KBW010-AA SH	HT7102	HT7667	UR193	UR270	HXV 061	UL120A	UL132	HHK 223	UR252A	UR253	EZ1436
105 kg (231 lbs)	85 kg (187 lbs)	21 kg (46 lbs)	19 kg (42 lbs)	29 kg (64 lbs)	20 kg (44 lbs)	0.5 kg (1 lbs)	35 kg (77 lbs)	36 kg (79 lbs)	7 kg (15 lbs)	22 kg (49 lbs)	12 kg (26 lbs)	30 kg (66 lbs)

HIS 184

HIS 179A PJ125E,V1E
HIS 073A PJ125C

Konstruktionsänderungen vorbehalten, fertigungstechn. Toleranzen müssen berücksichtigt werden.
Subject to change, production tolerances have to be taken into account.
Sous réserve de modifications de conception. Les tolérances relatives à la technique de production doivent être prises en considération.

KBW006-AA SHES
24.5kN (2.5t)

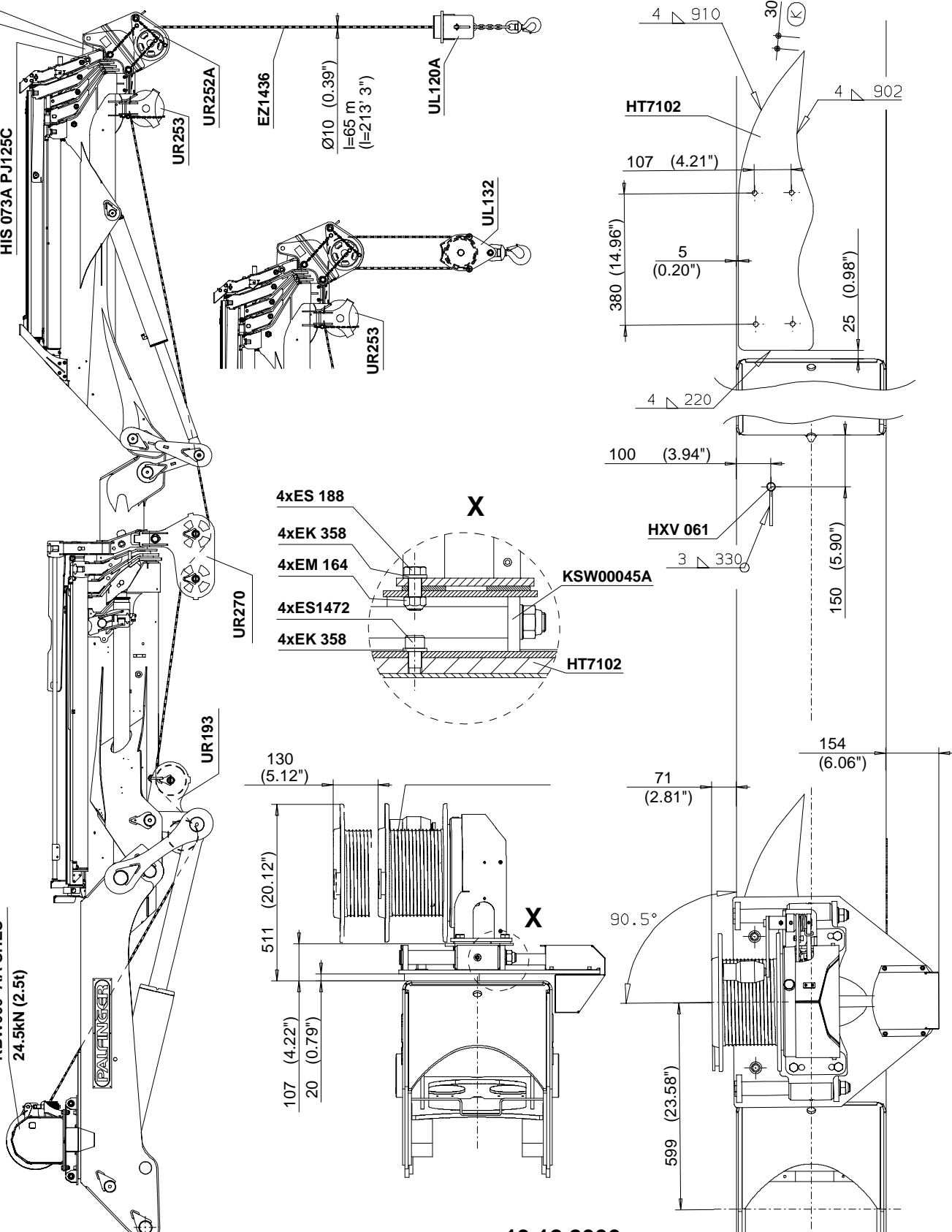

13.12.2006 →

KBW006-AA SHES	KSW00045A	HXV061	HT7102	HT7667	UR193	UR270	UL120A	UL132	HHK 223	UR252A	UR253	EZ1436
105 kg (231 lbs)	45 kg (99 lbs)	0.5 kg (1 lbs)	21 kg (46 lbs)	19 kg (42 lbs)	29 kg (64 lbs)	20 kg (44 lbs)	35 kg (77 lbs)	36 kg (79 lbs)	7 kg (15 lbs)	22 kg (49 lbs)	12 kg (26 lbs)	30 kg (66 lbs)