

PK 7501

Performance

PALFINGER



THE CRANE WITH THE LONGEST OUTREACH IN ITS CLASS



PK 7501 – A CRANE FOR TOUGH DAILY TASKS

Whether in road construction, the building materials trade or the municipal sector – the PK 7501 *Performance* is a crane for tough day-to-day duty.

The new hexagonal profile boom increases the rigidity of the arm system. With up to 5 hydraulic extensions the PK 7501 *Performance* has an outreach of 14 metres. This makes it the crane with the longest hydraulic outreach in the 7-metre-tonne class.



IT ALREADY MEETS THE REQUIREMENTS OF THE NEW CRANE STANDARD EN 12999

Return oil utilisation

The high speed of the extension system is impressive. It results from return oil utilization feature which is installed as standard, and the generously dimensioned hydraulic pipes. This makes for increased efficiency during all types of working!

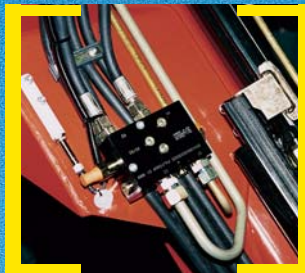

Load-holding valves

They prevent the crane arm from dropping and are fitted as standard on all cylinders. The valves are positioned in such a way that they are protected from damage.



Ergonomic crane control

The operating levers for all crane functions are arranged ergonomically on the console. This facilitates comfortable, efficient working. The control console is mounted so that it is easy to service.



Electronically assured safety

The optional PALTRONIC 50 electronic control system is a real advance in safety and convenience.

Hydraulic overload safety device

Also available as an option is the hydraulic overload safety device. In the event of overloading it immediately blocks any movements which would increase the load moment.

Radio control

The optional PALFINGER radio control system with digital data transmission provides maximum safety and convenience. The display which is integrated in the control console informs the crane operator continuously about the current capacity status of the crane.

In combination with the PALFINGER radio control system, the load sensing proportional valve enables the crane to be adjusted with great sensitivity.



PERFORMANCE – DESIGNED FOR SAFETY AND COMFORT WHILE WORKING



Hose equipment for accessories

This option provides the oil supply for accessories. The hoses are routed in compact hose troughs and are therefore well protected.

Internally routed oil passages

The internally routed oil make it possible to have a compact design for the extension system and ensure perfect protection from damage.

Central lubrication

For all bearings in the base frame.

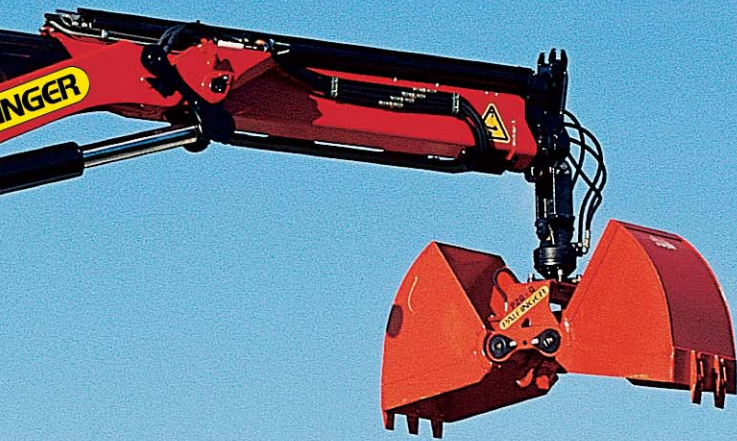

Extension system

- The extension cylinders are guided by using Jordal rails and rollers.
- Optimal height compensation of the extension cylinders.



Large outrigger widths

The PK 7501 *Performance* fits on all standard truck chassis. Three stabiliser spreads are possible: 3.2 m (mechanical), 4.9 m (mechanical or alternatively hydraulic) and 5.6 m (hydraulic).

TECHNICAL DATA

Max. lifting capacities

PK 7501 Performance			
hydraulic			
Max. lifting capacities		5400 kg	11900 lbs
Outreach		Capacity	
3.9 m	12' 10"	1840 kg	4060 lbs
5.4 m	17' 9"	1310 kg	2890 lbs

PK 7501 Performance A			
hydraulic			
Max. lifting capacities		5200 kg	11460 lbs
Outreach		Capacity	
3.9 m	12' 10"	1770 kg	3900 lbs
5.4 m	17' 9"	1230 kg	2710 lbs
7.4 m	24' 3"	890 kg	1960 lbs

PK 7501 Performance B			
hydraulic			
Max. lifting capacities		5000 kg	11020 lbs
Outreach		Capacity	
3.9 m	12' 10"	1700 kg	3750 lbs
5.4 m	17' 9"	1150 kg	2540 lbs
7.4 m	24' 3"	800 kg	1760 lbs
9.6 m	31' 6"	610 kg	1340 lbs
manual			
11.7 m	38' 5"	450 kg	990 lbs
13.7 m	44' 11"	360 kg	790 lbs
15.7 m	51' 6"	290 kg	640 lbs

PK 7501 Performance C			
hydraulic			
Max. lifting capacities		4900 kg	10800 lbs
Outreach		Capacity	
3.9 m	12' 10"	1640 kg	3620 lbs
5.4 m	17' 9"	1080 kg	2380 lbs
7.4 m	24' 3"	720 kg	1590 lbs
9.6 m	31' 6"	530 kg	1170 lbs
11.7 m	38' 5"	420 kg	930 lbs
manual			
13.7 m	44' 11"	320 kg	710 lbs
15.7 m	51' 6"	260 kg	570 lbs

PK 7501 Performance D			
hydraulic			
Max. lifting capacities		4800 kg	10580 lbs
Outreach		Capacity	
3.9 m	12' 10"	1580 kg	3480 lbs
5.4 m	17' 9"	1010 kg	2230 lbs
7.4 m	24' 3"	640 kg	1410 lbs
9.6 m	31' 6"	440 kg	970 lbs
11.7 m	38' 5"	330 kg	730 lbs
13.8 m	45' 3"	270 kg	600 lbs
manual			
15.8 m	51' 10"	210 kg	460 lbs

PK 7501 Performance

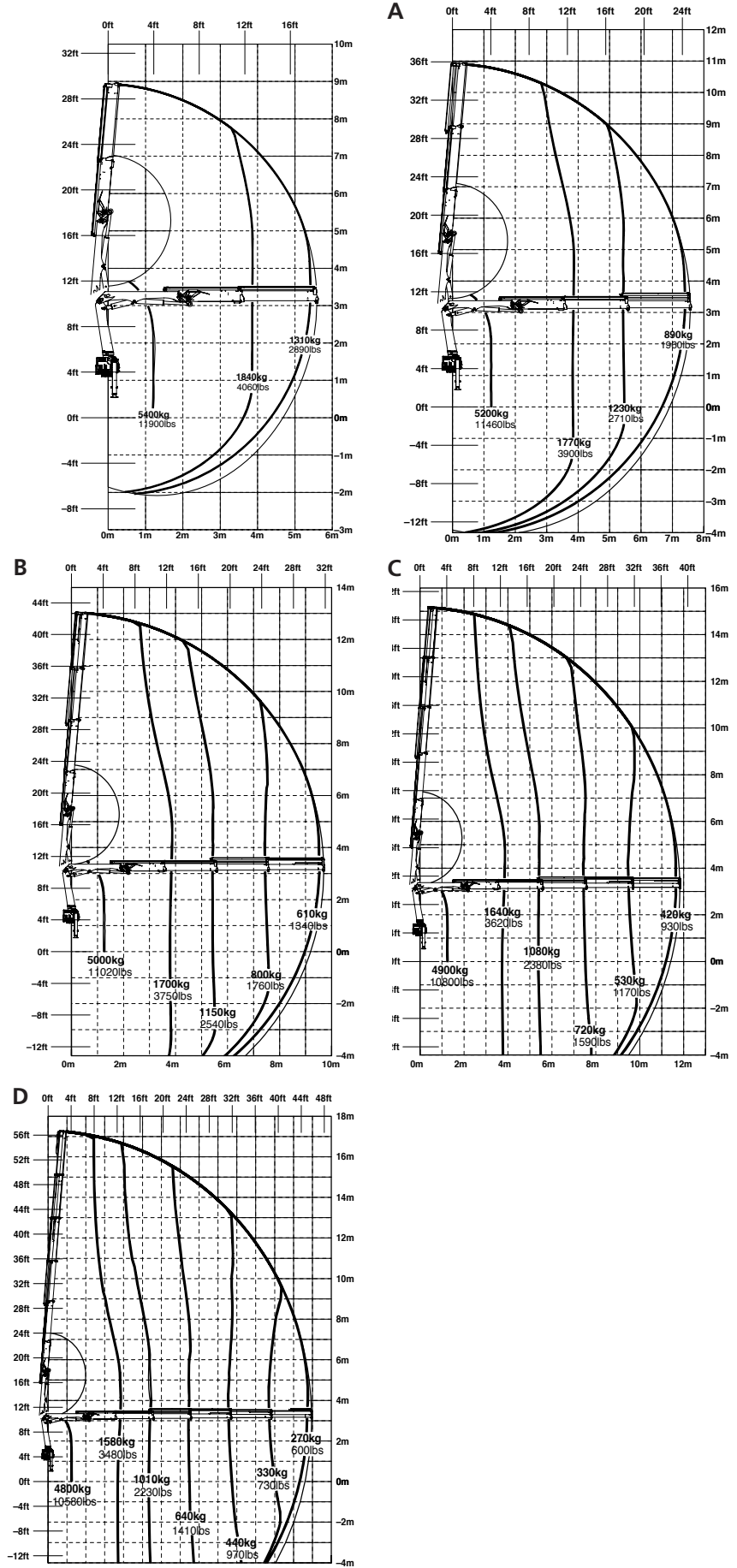

PALFINGER CRANES – PROVEN OVER DECADES

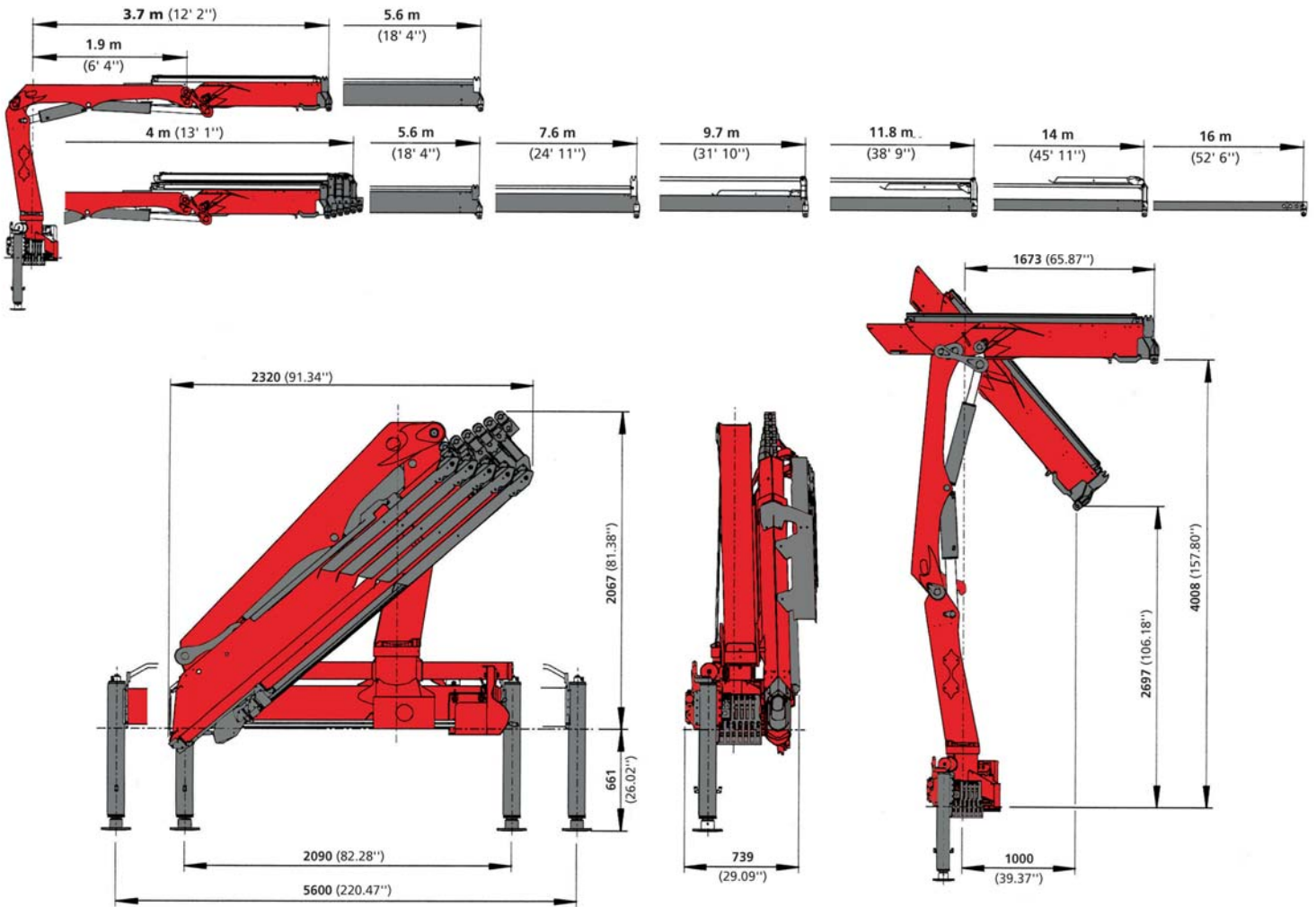

PK 7501 Performance		
Technical Specifications (EN 12999 H1-B3)		
Max. lifting moment	7.1 mt/69.7 kNm	51390 ft.lbs
Max. lifting capacity	5400 kg/53.0 kN	11900 lbs
Max. hydraulic outreach	14.0 m	45' 11"
Max. manual outreach	16.0 m	52' 6"
Slewing angle	400°	

PK 7501 Performance		
Standard crane		
Slewing torque	0.9 mt/8.8 kNm	6490 ft.lbs
Outreach	5.6 m	18' 4"
Stabilizer spread standard	3.2 m	10' 6"
Stabilizer spread max	5.6 m	18' 4"
Fitting space required	0.65 m	2' 2"
Width folded	2.3 m	7' 7"
Max. operating pressure	300 bar	4350 psi
Recommended pump capacity	from 5.5 imp.gal./min 6.6 US gal./min to 7.7 imp.gal./min 9.2 US gal./min	
with radio remote control and LS-System	from 8.8 imp.gal./min 10.6 US gal./min to 11.0 imp.gal./min 13.2 US gal./min	
Dead weight standard crane	968 kg	2130 lbs

Applications shown in the leaflet do not always correspond to the standard specifications. Design and specification are subject to change without prior notice. Country-specific regulations must be considered for the crane installation.

