



TEREX®

HR SERIES Hi-Ranger Overcenter Material Handling Aerial Device

AERIAL DEVICES

Terex® Hi-Ranger Aerial Devices are known throughout the industry. They come with a long history featuring quality and innovative design.

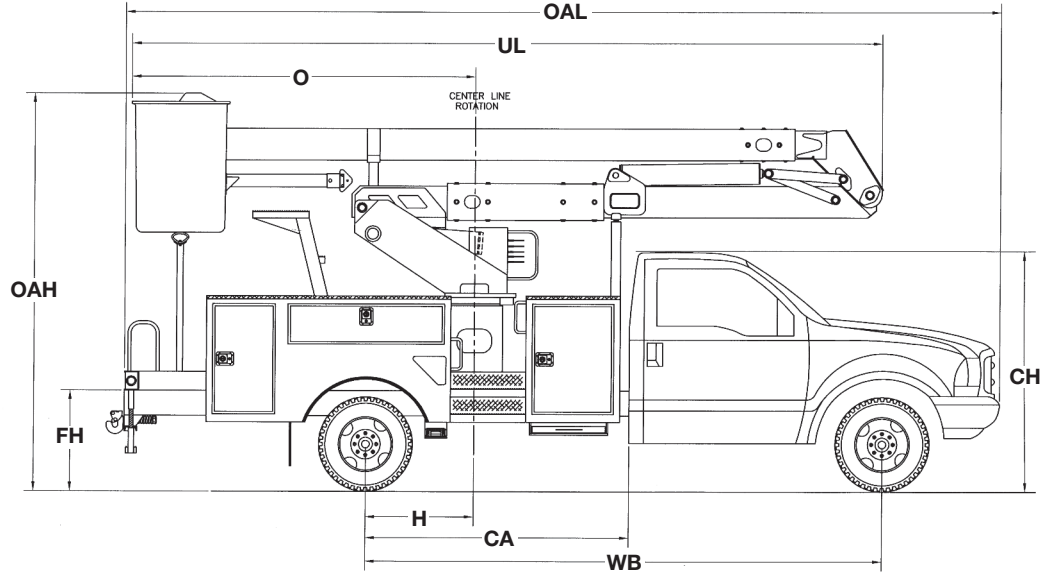

| Measurements | HR37 | HR40 |
|------------------------------------|-----------------------|-----------------------|
| | ORA | ORA |
| Typical Frame Height (FH) | 32 in. (81 cm) | 32 in. (81 cm) |
| Typical Cab Height (CH) | 78 in. (198.1 cm) | 78 in. (198.1 cm) |
| Offset (O) | 109.5 in. (278.1 cm) | 109.5 in. (278.1 cm) |
| Overall Height (OAH) | 10' 11" (3.3 m) | 10' 11" (3.3 m) |
| Overall Length (OAL) | 21' 1" (6.7 m) | 22' 1" (6.7 m) |
| Unit Length (UL) | 19' 11" (6.1 m) | 21' 6" (6.6 m) |
| Center of Rotation (H) | 34.5 in. (87.6 cm) | 34.5 in. (87.6 cm) |
| Cab to Axle (CA) | 84 in. (213.4 cm) | 84 in. (213.4 cm) |
| Wheel Base (WB) | 165 in. (419.1 cm) | 165 in. (419.1 cm) |
| Front Axle (FA) | 6,000 lb. (2,722 kg) | 6,500 lb. (2,948 kg) |
| Rear Axle (RA) | 11,000 lb. (4,990 kg) | 13,500 lb. (6,124 kg) |
| Gross Vehicle Weight Rating (GVWR) | 16,000 lb. (7,258 kg) | 19,000 lb. (8,618 kg) |
| Recommended Weight for Stability | 12,800 lb. (5,811 kg) | 14,000 lb. (6,356 kg) |
| Frame Section Modulus | 10.0 in ³ | 10.0 in ³ |
| Frame Yield Strength | 36,000 psi | 36,000 psi |
| Frame RBM | 360,000 in-lbs | 360,000 in-lbs |



TEREX®

500 Oakwood Drive
PO BOX 1150
Watertown, SD 57201-6150
USA

Phone: (605) 882-4000
Facsimile: (605) 882-1842
www.terexutilities.com
E-mail: utilities.info@terex.com

Distributed By:

HR SERIES

Hi-Ranger Overcenter Material Handling Aerial Device

STANDARD EQUIPMENT

- Side Mount 24" x 30" x 42" One-Person Platform
- Platform Capacity up to 350 lbs. (159 kg)
- Control-Plus "3-D" Single Stick Control at Platform
- Safety Harness With Attached Lanyard
- Continuous Unrestricted Worm Gear Rotation
- Category "C" Rating Per ANSI A92.2
- Rectangular, Bi-Axial Epoxy Resin, Filament Wound Fiberglass Booms
- Individual Lever Lower Controls
- Mechanical Platform Leveling System
- Two Speed Throttle Control at Upper Controls
- 200° of Upper Boom Articulation
- 102° of Lower Boom Articulation
- Full Pressure, Open-Center Hydraulic System
- 20 Gallon Hydraulic Oil Reservoir
- Padded Boom Rests with Upper Boom Tie Down
- Boom Interlock
- Moving Outrigger Alarm
- Truck Level Indicator

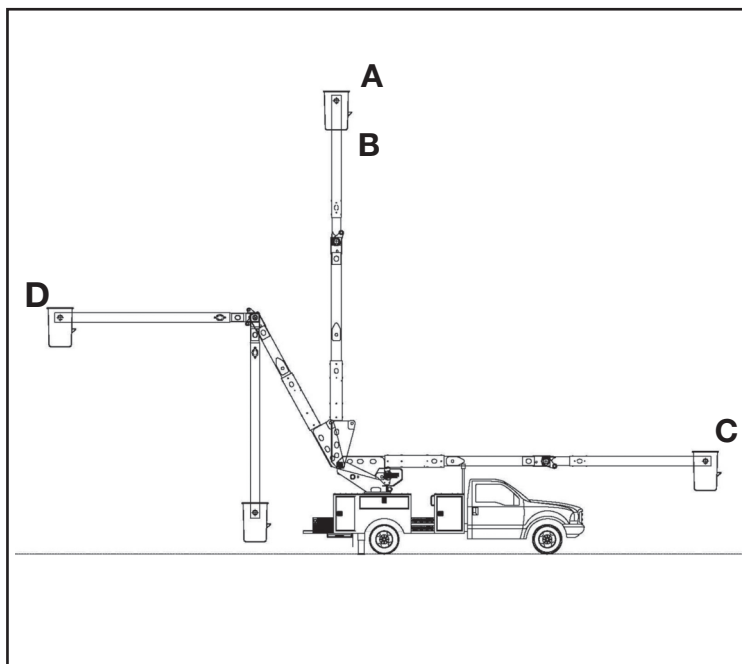

CAPACITIES & DIMENSIONAL DATA (Based on a 40 Inch Frame Height)

| | A | B | C | D |
|------|---------------------------|------------------|-----------------------------|-------------------------|
| | Bottom of Platform Height | Working Height | Side Reach (Non-Overcenter) | Side Reach (Overcenter) |
| HR37 | 37.8 ft (11.5 m) | 42.8 ft (13.0 m) | 27.1 ft (8.3 m) | 29.9 ft (9.11 m) |
| HR40 | 40.8 ft (12.4 m) | 45.8 ft (14.0 m) | 34.3 ft (10.5 m) | 28.9 ft (8.8 m) |

OPTIONAL EQUIPMENT

- Various Platform Covers
- Liners With Or Without Steps
- Hydraulic Platform Rotator
- 24" Platform Lifter
- Hydraulic Platform Tilt
- Jib Options
 - Hydraulic Jib Extension Systems
 - Hydraulic Articulating Jib/Winch, Side Mt. Or Underslung 1000 lbs.
 - Single Wire/46 Kv Insulated Single Line Lifter / Multi-Phase Attachments
- Category "B" Rating Per ANSI A92.2
- Lower Boom Lifting Eye
- Automatic Boom Latch
- Hydraulic Tool Outlets
- Engine Stop/Start
- Auxiliary Power
- Auxiliary Let Down System
- Demand Throttle
- Boom Overstow Protection
- Boom/Boom Stow Interlock
- Boom Storage Warning Light
- Outrigger Sag Light
- Various Types of Outriggers
- Truck Grounding Cable and Clamp
- Hybrid Enable
- HyPower™ Hybrid System by Terex®

Effective Date: March, 2010. Product specifications and prices are subject to change without notice or obligation. The photographs and/or drawings in this document are for illustrative purposes only. Refer to the appropriate Operator's Manual for instructions on the proper use of this equipment. Failure to follow the appropriate Operator's Manual when using our equipment or to otherwise act irresponsibly may result in serious injury or death. The only warranty applicable to our equipment is the standard written warranty applicable to the particular product and sale and Terex makes no other warranty, express or implied. Products and services listed may be trademarks, service marks or trade-names of Terex Corporation and/or its subsidiaries in the USA and other countries. All rights are reserved. Terex® is a registered trademark of Terex Corporation in the USA and many other countries. Copyright 2010 Terex Corporation.