

Specifications

Hydraulic Truck Crane

HTC-1050

50 Ton (45.36 metric ton)

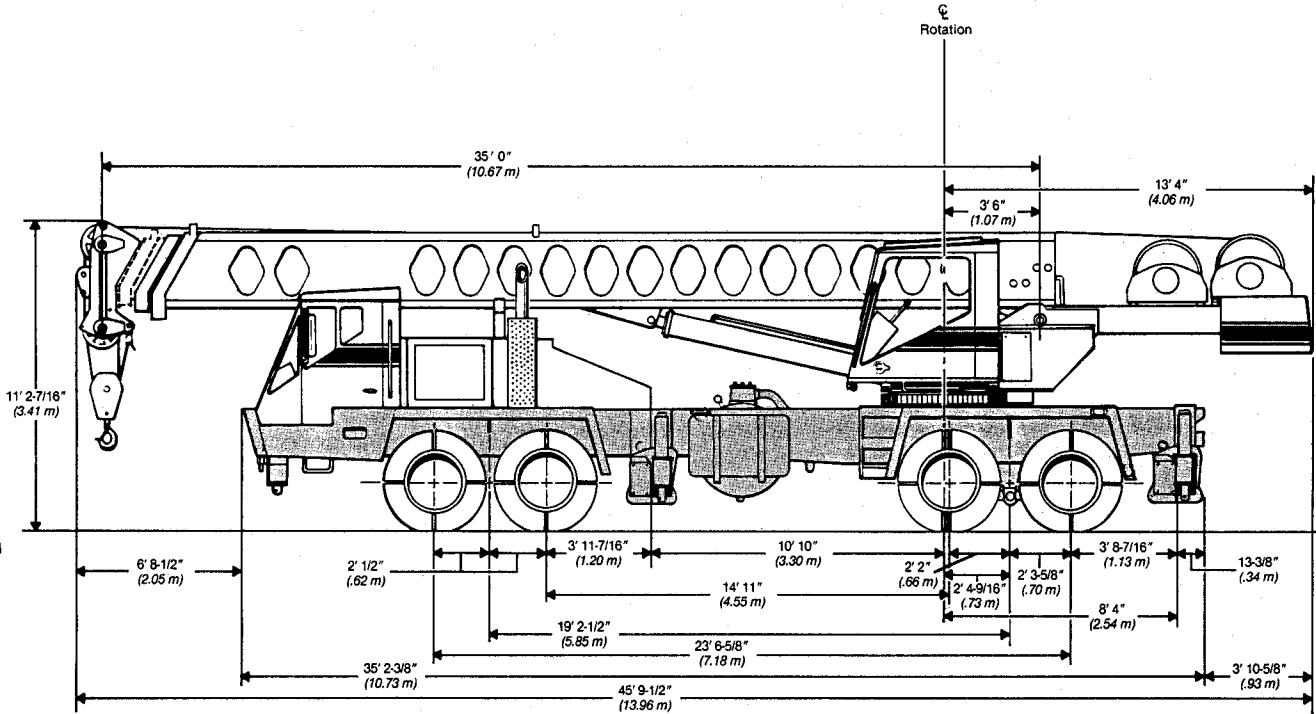

Not to Scale

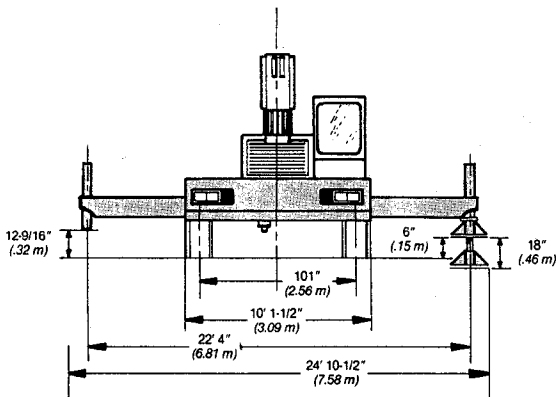

Not to Scale

General dimensions	feet	meters
Tailswing of counterweight	13' 7-3/16"	4.14
Ground clearance — Standard tires	9"	.23
Ground clearance — Optional tires	10"	.25
Turning radius — C / L of tire	51' 3-3/4"	15.64
Turning radius — (wall to wall) (outside front bumper)	54' 7-3/4"	16.66

GENERAL INFORMATION ONLY

Upperstructure

■ Boom

Link-Belt patented design. 35' 0" — 85' 0" (10.67 m — 25.91 m) three-section boom with two power sections. Boom side plates have diamond shaped impressions for superior strength to weight ratio and are offset welded to carefully machined 100,000 p.s.i. (689.5 MPa) steel angle chords for maximum integrity and strength. Boom telescope sections are supported by wear shoes both vertically and horizontally.

Load Moment Indicator — Audio-visual warning system with anti-two block and function kickouts. Constant display of boom length and angle, tip height, radius of load, machine configuration, allowed load, actual load and % of allowed load. Presettable alarms for maximum and minimum boom angles, maximum tip height and maximum boom length.

Optional Boom — 35' 0" — 110' 0" (10.67 m — 33.53 m) four-section boom includes base section, two power sections and manual fourth section. Fourth section is power pinned by manually activating a cylinder locking system.

Boom head — **Standard** are four 16-3/8" (0.42 m) root diameter head sheaves with five 16-3/8" (0.42 m) root diameter head sheaves available to handle up to 10 parts of 3/4" (19 mm) wire rope. Two removable wire rope guards and rope dead end lugs are provided on each side of the boom head.

Auxiliary lifting sheave — **Optional**; Single 16-3/8" (0.42 m) root diameter head sheave with removable wire rope guards, mounted to boom. For use with one or two parts of line off the optional auxiliary winch. Does not affect erection of jib or use of main head sheaves for multiple reeving.

Boom elevation — Two Link-Belt designed double-acting hydraulic boom hoist cylinders with integral holding valves. Hand or optional foot controls for boom elevation from -3° to 78°.

■ Fly

Optional — 33' 0" (10.06 m) stowable one-piece lattice type.

■ Jib

Optional — 25' 0" (7.62 m) stowable A-frame. Can be offset 5°, 17.5°, and 30°. Attaches to fly only.

■ Cab and Controls

Environmental cab; isolated from sound and vibration by rubber mounts. All tinted and tempered safety glass windows. For maximum visibility and ventilation, sliding right side and rear window and swing up roof window supported with two gas cylinders. Slide-by-door opens to 3' 0" (0.91 m) width. Six-way adjustable operator's seat. Control levers for swing, boom telescope, winch and boom hoist, with foot control for swing brake and optional boom hoist. Outrigger controls, sight level bubble.

Cab instrumentation — Dash-mounted gauges for hydraulic oil temperature, fuel, water temperature, and oil pressure.

■ Swing

Bi-directional hydraulic swing motor mounted to a two-stage planetary reducer for 360° continuous smooth-swing at 2.45 r.p.m.

Swing brake — **Standard**; foot operated, spring released disc brake mounted on the speed reducer.

Swing lock — **Standard**; 360° position pin-type controlled from the operator's cab. Two position house lock for travel and pick and carry modes.

Counterweight — Pinned to upperstructure frame. 10,000 lb. (4 536 kg) counterweight with single-winch system. 9,050 lb. (4 105 kg) counterweight with two-winch system. Optional counterweight removal system is available.

■ Hydraulic System

Main pump — Four-section gear-type pump. Combined pump capacity 193 gpm (730.5 lpm). Powered by carrier engine with manual pump disconnect which is operated from carrier cab. Maximum system pressure 2,900 p.s.i. (200.0 Bars). Hydraulic oil cooler is standard

Reservoir — Link-Belt, 140 gallon (530.0 L) capacity. Diffusers for deaeration.

Filtration — One six-micron filter located inside the hydraulic reservoir.

Control valves — Six separate control valves allow simultaneous operation of all crane functions.

■ Load Hoist System

Standard — Model 2M main winch with two-speed motor and automatic brake; power up/power down mode of operation. Bi-directional gear type hydraulic motor.

Optional — Model 2M auxiliary winch with two-speed motor and automatic brake, power up/power down mode of operation. Bi-directional, gear-type hydraulic motor.

Optional — Model 3M winch with power up/power down, two-speed motor and exclusive controlled true gravity freefall. Available on main or both winches.

Line pulls and speeds — Maximum line pull is 15,870 lbs. (7 199 kg) and maximum line speed is 548 f.p.m. (167.03 m/min) on 17" (0.43 m) root diameter drums.

■ Additional Upperstructure Equipment - Optional

Boom hoist foot control, drum rotation indicators, propane heater, diesel heater, 60-ton (54.43 metric ton) hook block, 8-1/2 ton (7.72 metric ton) ball and swivel, roof window windshield wiper, flood lights, lifting lug package, hand throttle, air conditioning, windshield washer, amber rotating beacon, cab mounted spotlight, tachometer and engine monitoring system.

GENERAL INFORMATION ON

Carrier

■ Type

Link-Belt 8 x 4 drive, 10' 1-1/2" (3.09 m) wide, 230-1/2" (5.85 m) wheelbase.

Frame — All-welded high strength alloy steel plate construction with box-type design and integral 100,000 p.s.i. (689.5 MPa) steel outrigger boxes.

■ Outriggers

Power hydraulic, double box, single beam outriggers, front and rear. Vertical jack cylinders, each with integral holding valve. Beams extend to 22' 4" (6.81 m) centerline-to-centerline and retract to within 10' 1-1/2" (3.09 m) overall width. Equipped with stowable, lightweight 30-1/2" (.77 m) diameter floats. Controls and sight level bubble located in upperstructure cab.

Front bumper outrigger — Standard; Front center vertical jack mounted under bumper with 20" (0.51 m) square lightweight float. Provides 360° lifting capacities.

■ Axles

Front Tandem; 101" (2.57 m) track.

Rear Tandem; 90" (2.29 m) track, 6.83 to 1.0 ratio with interaxle differential lockout.

■ Suspension

Front Spring suspension with torque rods.

Rear Solid mount 54" (1.37 m) bogie beam.

■ Wheels

Front — Cast six-spoke.

Rear — Cast six-spoke.

■ Tires

Standard Front — 16.5 x 22.5 (16 PR) transport type tubeless.

Standard Rear — 11.0 x 20.0 (14 PR) transport type with tube.

Optional Front — 18.00 x 22.5 (16-PR) transport type tubeless.

Optional Rear — 12.00 x 20.0 (14 PR) transport type with tube

Optional Rear — 12.00 x 20.00 (14-PR) lug type.

Optional Front — 445/65R22.5 XZY lug type radials.

Optional Rear — 12R20 XZA transport type radials.

Optional Rear — 12R20 XZY lug type radials

■ Brakes

Full air on all wheels. Air dryer is standard.

■ Service

Front — 8 x 4 Cam-type 15" x 6" (.38 m x .15 m) shoe diameter.

Rear — Cam-type 16-1/2" x 7" (0.42 m x .18 m) shoe diameter

Parking and emergency — One spring set, air released chamber per rear axle end. Parking brake applied with valve mounted on carrier dash. Emergency brakes apply automatically when air pressure drops below 60 p.s.i. (4.14 Bars) in both systems.

■ Steering

Sheppard Steering, rack-and-pinion design. Provides wall-to-wall turning radius of 54' 7-3/4" (16.66 m).

Clutch — Lipe-Rollway 14" (0.36 m) diameter, spring loaded, double plate dry disc.

Universals — Rockwell or Spicer; easy service type.

■ Transmission

Standard — Fuller Roadranger RTO-6613; 13 speeds forward, three reverse.

■ Electrical System

Two 12-volt batteries; 2,230 cold cranking amps available, 80 amp alternator.

Lights — Four dual-beam sealed headlights, front and rear directional signals, stop and tail lights, four-way emergency flashers, back-up lights, front, rear and side clearance lights with integral reflectors and license plate light.

■ Carrier Cab

One-man cab. Acoustical insulation with vinyl covering. Equipped with electric windshield wiper and washer, horn, four-way adjustable seat with seat belt, dome and dash lights, cigar lighter, ashtray, 22,400 BTU capacity heater, defroster, door and window locks, fire extinguisher, LH/RH rear view mirrors, tilt/telescoping steering wheel and sliding LH/RH and rear tinted windows.

Cab instrumentation — Standard; illuminated instrument panel with speedometer, odometer, tachometer, voltmeter, hourmeter, front and rear air pressure gauges, low air pressure light and warning buzzer, automotive-type ignition (common with upper), engine oil pressure gauge, water temperature gauge, fuel gauge, turn signal indicator, high beam light switch, adjustable defroster vents and circuit breakers.

■ Additional Equipment - Standard

Front and rear fenders, air dryer, back-up warning alarm, cab steps, access ladder to rear carrier deck with hand grab rails, front/rear tow loops, and skid-resistant finish on carrier deck and mud flaps.

■ Additional Equipment - Optional

Engine block heater, ether injection starting package, spare tire and rim assemblies, front and rear towing shackles and engine monitoring system.

Travel Speeds and Gradeability ①

Engine	Maximum Speed		Maximum Gradeability at peak engine torque
	mph	km/h	
Cummins 6CTA 8.3	50.4	81.1	34%

① Maximum speed based on full load r.p.m. Gradeability is based on peak torque of the engine, lowest forward gear and machine equipped with standard tires. Gradeability values above 58% (30°) are theoretical due to engine oil pan limits.

Engine	Cummins 6CTA 8.3
Cylinders / cycle	6 / 4
Bore	4.5" (0.11 m)
Stroke	5.32" (0.14 m)
Displacement	504.5 cu. in. (8 267 cm ³)
Gross engine power	240 hp @ 2200 rpm
Peak torque	645 ft. lbs. (874.62 J)
Electric system	12 volt negative ground
Fuel capacity	100 gallons (378.5 L)
Alternator	80 amps
Crankcase capacity	21.7 quarts (20.54 L)
Air compressor	13.2 c.f.m. (0.37 m ³ /min)

Axle Loads

Base machine with 35'-85' (10.67m- 25.91m) 3-section boom, main winch with two-speed hoisting and power up/down, 600' (182.88 m) 3/4" (19mm) hoist line, 8x4, 10' (3m) carrier with Cummins 6CTA 8.3 diesel engine, front bumper outrigger, Roadranger transmission, full fuel and hydraulics.	G.V.W. ①		Upper facing front				Upper facing rear			
			Front axle		Rear axle		Front axle		Rear axle	
	lbs.	kg	lbs.	kg	lbs.	kg	lbs.	kg	lbs.	kg
	60,533	27 453	30,320	13 750	30,213	13 703	13,906	6 307	46,627	21 14
35'-110' (10.67 m - 33.53 m) 4-section boom	1,952	885	1,808	820	144	65	-1,325	-601	3,277	1 48
Counterweight for single winch	10,000	4 536	-4,916	-2 230	14,916	6 765	7,394	3 353	2,606	1 18
Counterweight for two winches	9,050	4 105	-4,449	-2 018	13,499	6 122	6,692	3 035	2,358	106
Freefall main winch with 600' (182.88 m) rope	442	200	-128	-58	570	259	237	108	205	9
Power up/down aux. winch with 465' (141.73 m) rope	1,758	797	-534	-242	2,292	1 039	970	440	788	35
Freefall aux. winch with 465' (141.73 m) rope	2,200	998	-598	-271	2,798	1 269	1,143	518	1,057	47
33' (10.06 m) lattice fly, stowed	1,040	472	902	409	138	63	-644	-292	1,684	76
25' (7.62 m) A-frame jib, stowed	1,128	512	744	337	384	174	-464	-211	1,592	72
Hook block at bumper	1,070	485	1,657	751	-587	-266	—	—	—	—
Headache ball at bumper	325	148	503	228	-178	-80	—	—	—	—
Auxiliary lifting sheave	150	68	280	127	-130	-59	-243	-110	393	17
Fly and jib stowage brackets	230	104	117	53	113	51	-60	-27	290	13
12.0 x 20.0 rear tires with rims and wheels	413	187	—	—	413	187	—	—	413	18
18.0 x 22.5 front tires and rims	136	62	136	62	—	—	—	—	—	—
Counterweight removal system	120	54	-58	-27	178	81	88	40	32	1

① Adjust gross vehicle weight & axle loading according to component weight.
Note: All weights are ± 3%.

GENERAL INFORMATION ONLY

Maximum Front Axle Load Table

Tire	Maximum Front Axle Load @ 50 mph (80.45 km/h) *
16.5 x 22.5 H	39,500 lbs. (17 197 kg)
18.0 x 22.5 H	40,000 lbs. (18 142 kg)

* For speeds exceeding 50 mph (80.45 km/h) see Operator's Manual.

● Link-Belt is a registered trademark.

We are constantly improving our products and therefore reserve the right to change designs and specifications.

Link-Belt Construction Equipment Company Lexington, Kentucky

A unit of Sumitomo Construction Machinery Co., Ltd.