

NATIONAL N-135

Truck-Mounted Articulating Cranes and Accessories

Maximum Capacity: 19,000 Pounds (10.5 Metric Tons)

Reach Above Truck Frame: 49 Feet (14.9 Meters)

Reach Below Truck Frame: 32 (9.8 Meters)

Horizontal Reach: 41 Feet (12.5 Meters)



**America's Truck-Mounted
Hydraulic Crane Leader**

National N-135 Articulating Crane

National Crane, America's truck-mounted hydraulic crane leader, manufactures an extensive line of telescoping and articulating cranes. The N-135, a high-capacity articulating crane, exemplifies National's field-proven know-how and commitment to quality. This all-new articulating crane reflects National's quarter-century of manufacturing expertise. It is a well-engineered, tough and dependable unit designed for ease of operation.

The N-135, coupled with practical, cost-efficient accessories, can perform a wide-range of functions. It is ideal for general purpose lifting, loading and unloading. The unit's light weight and wide outriggers give you impressive payload capabilities. When not in use, the N-135 stows compactly behind the cab.

- 19,000-pound (10.5 MT) rated capacity
- 49-foot (14.9 m) vertical reach
- 41-foot (12.5 m) horizontal reach
- 32-foot (9.8 m) reach below truck frame
- Booms constructed from high-strength, low-alloy steels
- Inner boom is offset at its base to allow the lengthy outer boom to stow alongside the mast, resulting in longer reaches and larger capacities while maintaining a lightweight, compact unit when stowed
- The outer boom extends and retracts smoothly in sequence on long-wearing, lubricant-impregnated wear pads powered by a sequentially-controlled, two-stage cylinder
- Lightweight manual jibs constructed of high-strength, low-alloy steel extend the working range of the crane quickly and easily
- Jibs pin in place with pins carried at the jib-tip

- The boom nose or jib nose is equipped with a swivel hook (rated for maximum crane capacity) with a safety latch and is designed to accept all boom-tip options via a simple pin-on procedure

- Counterbalance valves on the lift, fold, and extend cylinders hold these cylinders in place until they are powered to move; they hold the cylinders in place in the event of hose failure and serve as overload relief valves to slowly lower the load in the event of an overload condition

- Large-diameter, chrome-plated pins combined with composite bearings provide long life with reduced maintenance

- Efficient, low-maintenance shear ball rotation bearing combined with a planetary gearbox and a high-torque, low-speed motor provide smooth precise planetary control

- When unpowered, the swing is locked in place by a spring-applied, hydraulically-released brake

- Wide, fully-hydraulic outriggers

- All hoses are routed internally where possible to protect against damage and to enhance the crane's appearance

- Inline hose swivels which rotate with the mast protect the hoses from kinking and abrasion, and help keep the end connections tight

- A new control valve with low-effort, special metering spools allows for the precise control of all crane functions

- Dual, waist-level controls with identical operations of normal crane functions are positioned on both sides of the machine

- Mounts on standard, single axle trucks

- Three-point, clamp-on mount simplifies crane mounting and reduces crane and truck frame stress

Built strong

The National N-135, though light in weight, is designed for tough materials-handling jobs. We manufacture it from extra-tough, low-alloy, high-strength steel for exceptionally high strength-to-weight ratio.

Special lock valves hold the lift, fold, and extend cylinders in place in the event of hose failure and serve as overload relief valves to slowly lower the load in the event of an overload condition.

Cylinder shafts are hard-chrome plated. And high-pressure tubing is used wherever possible to reduce hose wear.

The heavy-duty wire-braided hydraulic hoses are routed inside structural members where possible for protection from bumps, twists, cuts and abrasions. Our special three-point mounting system absorbs loading flex, protecting the truck frame from excessive stress.

Every N-135 undergoes hundreds of quality control inspections, including ultrasonic testing for weld penetration. All prototype models are stress tested and run through thousands of brutal work cycles to make sure your N-135 will work year after year

Heavy-duty hydraulics

All N-135 couplings and fittings are high quality. All hydraulic hoses, tubes and fittings have a 4:1 minimum safety factor on burst. All cylinders are double acting for smooth, positive control.

High-capacity, heavy duty pumps are standard. An efficient, high-pressure vane pump produces full system pressure even at truck engine idle speed and maintains high efficiency throughout its life. A two-bolt mounting flange can be integrally mounted to most PTO's to simplify mounting.

A specially-designed oil tank with an oil level sight

gauge, breather, magnetic plug, and a 10-micron external return line filter integrally mounted to the crane frame reduces mounting time and space requirements. The oil tank is detachable for fast, easy maintenance.

Wide, fully-hydraulic outriggers for stability, fast set-up

Standard, wide-span, hydraulic out-and-down outriggers are constructed from high-strength, low-alloy steel to form a lightweight, stable base which can be set up quickly from either side of the truck. Outriggers extend 19 feet 8 inches horizontally and 24½ inches vertically. The wide stance allows for lower truck chassis weight requirements and more payload capability (up to 11,500 pounds on a minimum single axle truck). The large outrigger footpads provide solid stability in soft or uneven ground conditions.

Outrigger vertical legs lock in place up or down by pilot-operated check valves. The vertical cylinders lock automatically when stowed, so they will not leak down in transit. The legs are removable to facilitate shipment or storage.



National Warranty, Parts and Service

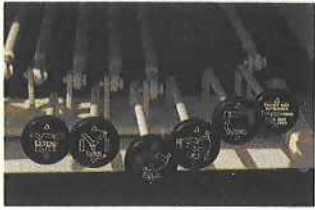

Easy operation

The N-135 provides dual, waist-level controls with identical operation of normal crane functions. The operator can work the controls from either side of the crane and keep the boom and load in full view at all times. The control knobs are illustrated with function symbols and operate smooth, fine-metering, five-spool control valves for pinpoint accuracy. The boom can be worked and rotated simultaneously. You won't find a crane that's easier to operate. Additional valves banks can be added easily for operating any of our many hydraulic accessories.

Efficient shear ball bearing rotation

The N-135 is the first National articulating crane to utilize a highly efficient, low-maintenance shear ball bearing rotation system powered by a high-torque, low-speed motor through a double-reduction planetary gearbox. The system, field-proven in our telescoping line, provides smooth, precise planetary control. When unpowered, the swing is locked in place by a spring-applied, hydraulically-released brake.

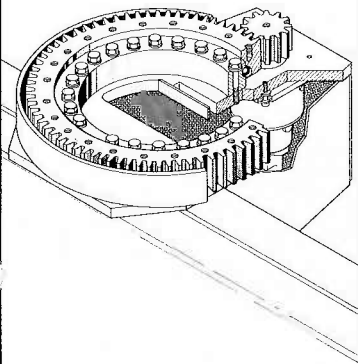

American-made

All National cranes are manufactured in America. Parts are readily available and service is easily obtained, should you need it.

The National Testing Program

National Crane established its original product durability standards by carefully evaluating the performance of competitive machines. Taking the best performances from these tests, National engineers set their own standards **more than 50% higher!** This is the same testing standard each National must pass today.

Before a new model is released for production manufacturing it is subjected to state-of-the-art testing. For example, a plastic-based "brittle lacquer" coating is applied to the crane. After loading, test engineers inspect the coating for cracks. The special lacquer has virtually no elastic qualities, so stretching or deformation of the metal shows up in "fractures" of the coating, perpendicular to the direction of stretching.

This procedure indicates where engineers are to place strain gauges, tiny chips printed with electronic circuitry which expand or contract with changes in the metal. Minute changes in electrical resistance are measured by a computerized strain gauge monitor and printed out for engineering studies. Strain gauges measure metal deformation as small as one-millionth of an inch.

After strain gauge testing, the prototype of each new model undergoes life-cycle testing. The crane is operated at full-load through a full life-cycle under close scrutiny. Outriggers, frames, and other components are loaded and rotated through a complete

The National Warranty

National's warranty covers your crane against defects in materials or workmanship for **six full months** from the date of shipment, subject to the conditions of the warranty.

When you select a National crane, you're getting more than just a crane. You're getting a nationwide dealer warranty service network, strong warranty protection and our special concern for every product we make.

Read our warranty. Then, don't settle for less. For complete information, write National Warranty Service, Waverly, NE 68462.

The National Parts System

Authorized National Crane dealers maintain a parts supply to support the National cranes in each dealer's area. If a dealer cannot immediately supply a needed part, the factory maintains a backup parts supply that provides

24-hour parts shipping in 85% of all breakdown rush orders. National's responsiveness to dealer requests means that your crane will be back on the job fast. National maintains a highly trained Service and Parts staff to answer dealer service questions and expedite parts shipping.

The National Service Center

National maintains a well-equipped service center where we do all our factory crane mounting. The central location of our Service Center makes it easy to return cranes for special modifications or extreme repairs. Most National dealers can perform all but the most unusual modifications or most serious repairs.

Should you need to return your crane to us for modification, warranty repair or other service, we will give it priority care and see it's returned as soon as possible.

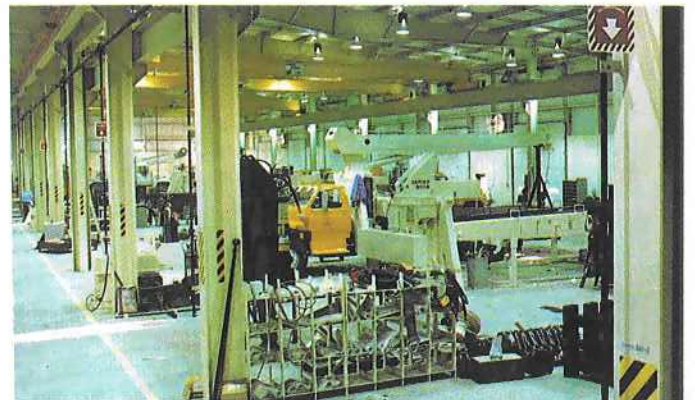

range of motion for the prescribed number of cycles.

All components used on National cranes are subject to a multi-level inspection program during manufacture and assembly. National's attention to testing ensures that each crane delivered to the field is ready for on-the-job action.

Caution

Do not operate crane booms, jib extensions, any accessories, or loads within 10 feet (3m) of live power lines. Jib and boom capacities shown are maximum for each section. Do not exceed capacities at reduced radii.

National N-135 Articulating Crane

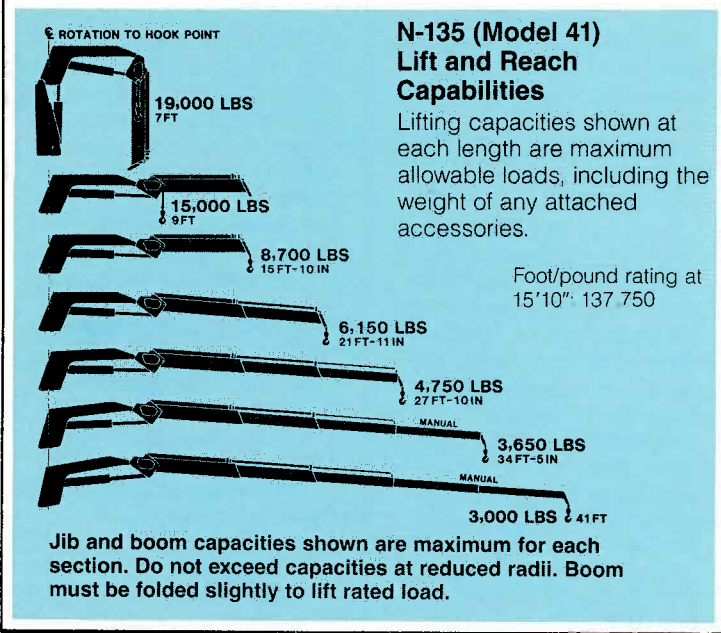

The Basic Unit (Model 28)*

- Hydraulic reservoir
- Two hydraulic outriggers with hydraulic extension to 19' 8" span
- Frame, inner boom, outer boom with two hydraulic extensions to 27' 10"
- 410° rotation
- Five spool control valves
- Identical dual controls positioned on each side of crane
- Boom cylinders have pilot operated holding valves with internal safety relief valves to help protect against overload and hose failure
- Crane hook
- Hydraulic pump and easy mounting group

*Model 41 is the same as the basic unit but with two manual extensions providing a reach of 41'

Maximum reach (Model 28)

- Above truck frame to 36 feet
- Below truck frame to 18 feet
- Horizontal to 27 feet 10 inches

Technical Data

| | |
|---|--|
| Working Pressure..... | 3,100 psi |
| Pump Capacity (vane-type pump)..... | 17 gallons/min. |
| Reservoir Oil Capacity | 22 gallons |
| Outrigger Span | 19' 8" |
| Stowed Height (above truck frame)..... | 7' 9½" |
| Weight (135/41)..... | 6,250 lbs.* |
| Filter | 10 micron replaceable (spin-on type) filter |
| Rotation..... | 410° |
| Mounting Space Required | 40" |

*Weight includes 19'8" outriggers

Special Safety Features

- Overload relief with holding valves on lift, fold and extend cylinders help to protect against overload and hose failure
- Dual hydraulic controls with identical operations on each side
- Hoses routed internally for protection
- Double-acting cylinders
- Pilot operated outrigger check valves (standard)

Manual Extension Option (Model 41)

Add extra versatility and reach to your N-135 by specifying the H41 option. It adds two manual boom extensions.

The hydraulic extensions retract and extend under full load up to 27' 10". The two manual extensions extend the reach to 41 feet. Held in or out with two pins carried right at the boom tip, the manual pull-outs are quick to rig, easy to use.

Maximum Reach

- Above truck frame to 49 feet
- Below truck frame to 32 feet
- Horizontal to 41 feet



National N-135 Mounting Specifications

| Mounting It is essential that the truck used for mounting this crane meet the minimum requirements (shown at right) for capacity loads. | Minimum Truck Specifications | |
|--|---|---|
| | 180° Working Area | 360° Working Area |
| Minimum Wheelbase | 222 inches | 204 inches |
| Rear of Cab to Rear Axle | 144 inches | 126 inches |
| Recommended Axle Rating (Front)* | 12,000 pounds GAWR* | 12,000 pounds GAWR* |
| Recommended Axle Rating (Rear) | 18,000 pounds GAWR | 34,000 pounds GAWR |
| Working Area | 180° | 360° |
| Truck Weight | 11,900 pounds (3) | 15,600 pounds (3) |
| Chassis Weight Front Axle* | 6,900 pounds minimum* 7,900 pounds maximum | 6,900 pounds minimum* 7,900 pounds maximum |
| Chassis Weight Rear Axle | 5,000 pounds minimum (3) | 8,700 pounds minimum (3) |
| Frame | 26-inch ³ section modulus with 50,000 PSI yield steel = 1,300,000 in-lb rbm 15.9-inch ³ section modulus with 100,000 PSI yield steel = 1,590,000 in-lb rbm | |
| Frame Height | 42 inches or less preferred | |
| Power Take-Off | 70-80 percent of engine speed. Minimum horsepower 30 at 1,400 rpm | |
| NOTES: (1) GAWR means Gross Axle Weight Rating and is dependent on all components of the vehicle such as axles, tires, wheels, springs, brakes, steering and frame strength meeting manufacturer's recommendations. Always specify GAWR when purchasing trucks. (2) Minimum axle requirements may increase with use of diesel engines, longer wheelbase or service bodies. Contact factory for further information. (3) Chassis weight includes bed. (4) Diesel engines require variable speed governor. | | |
| | <p>*If front axle chassis weight is less than 6,900 pounds, counterweight may be required to lift rated capacity loads to keep unit stable.</p> | |

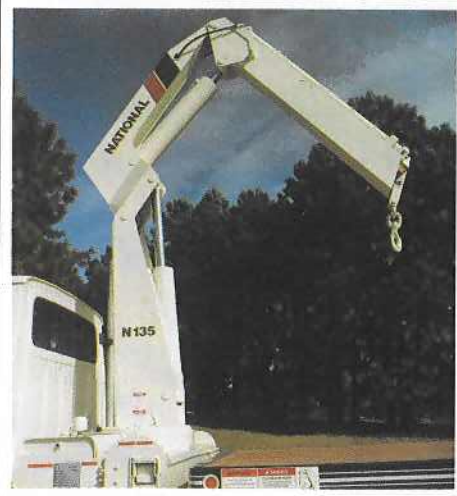

National N-135 Options and Accessories

Every National N-135 is more than just a crane. It's part of a complete lifting system.

The National Lifting System equips your crane to do more than just lift or handle materials. The accessories shown here enable one truck-mounted N-135 to perform jobs that typically require a whole fleet of specialized, expensive vehicles. With a National, you can do more, faster, with less equipment and less manpower. That's money in your pocket.

NOTE:

Weights of all accessories attached to the boom or loadline of the crane must be deducted from the effective lifting capacity. Some accessories cannot be used in combination with other accessories. Consult your dealer for specific accessory availability.

Accessory Control Valves

These additional control units are required for the operation of hydraulic accessories. Comes complete with controls for both sides of your machine, hoses, quick couplers and piping to the end of the second hydraulic extension. Available in two models: AH1 single function for rotator or auger and AH2 with two functions for grapple or clam bucket. Mounts easily on existing control panel.

- Model AH1
- Model AH2

Caution
Do not operate crane booms, jib extensions, any accessories, or loads within 10 feet (3 m) of live power lines. Jib and boom capacities shown are maximum for each section. Do not exceed capacities at reduced radii.

Remote Control

The latest edition of our one-hand remote control. Ideal for use where precise control and total load visibility are required. Fine metering and instant response enables operators to position loads easily.

Now, it's more reliable than ever with solid state circuitry and fewer parts than previous systems we have offered. Other improvements include higher operating speeds and modular design. Works with standard dual controls. MR4 for lift, turn, fold and extend. MR5 is the same as MR4, plus one accessory. MR6 is the same as MR4, plus two accessories.

Priority control valve operated by a trigger on the remote control unit, regulates oil flow and gives you fingertip speed control over all crane functions.

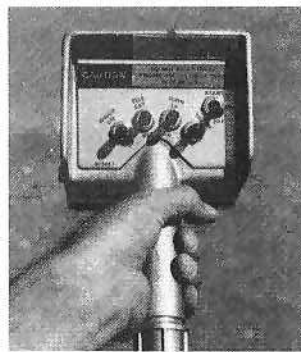

- Model MR4
- Model MR5
(Requires one accessory)
- Model MR6
(Requires two accessories)

Note: Diesel engines require an electric engine shutoff.

Hydraulic Auger

This popular N-135 accessory gives you digging depths to 4½ feet (1.8 m) and flightings up to 18 inches (46 cm). Attaches easily, works fast and disconnects quickly. Requires AH1 Accessory Control Valve group. Optional extension will provide a digging depth to 6½ feet (2.4 m). Contact factory for details.

- Reach.....27' 10"
- Reduction.....4:1
- RPM.....85 rpm at 17 gpm
- Pressure.....3,000 psi
- Pump.....17 gpm required
- Torque Output.....1,500 ft./lbs.
- Drive Weight.....205 lbs.
- Length.....48" overall
- Controls.....Requires AH1 hydraulic control valve option

Flightings and Weight

| Flightings | Length | Weight |
|------------|------------|----------|
| 9" | 30" double | 66 lbs. |
| 12" | 30" double | 78 lbs. |
| 15" | 30" double | 92 lbs. |
| 18" | 30" double | 123 lbs. |

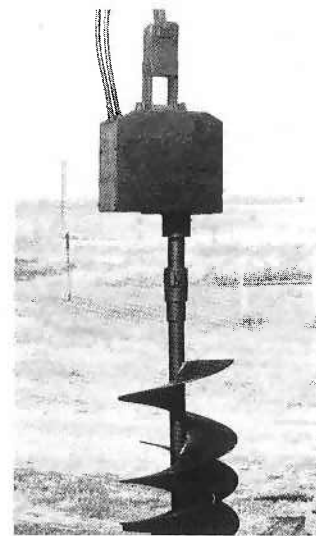

Model AG

Clam Bucket and Grapples

Turn your N-135 into more than a crane with National clam bucket or grapple attachments. The clam bucket can be used to load or move loose materials in ½ cubic yard (.25 m³) bites. The grapples, available in butt or bypassing type, will get a grasp on difficult handling jobs. Butt type handles up to ⅓ cord, bypassing will pick up 36-inch (91 cm) log or pipe. One person can install and remove bucket or grapples. Both come with hydraulic rotator and quick-connect fittings. Require AH2 Accessory Control Valves.

| | Butt Type | By-passing | Clam |
|-------------------------|-------------|--|--------------------|
| Capacity | ⅓ cord | 36" log or pipe | ⅓ yd. ³ |
| Rotation Opening | 315° | 315° | 315° |
| Max. | 72" | 66" | 72" |
| Min. | 30" | 6" | |
| Weight | 650 lbs. | 650 lbs. | 650 lbs. |
| Height | | | |
| Open | 38" | 41" | 38" |
| Closed | 58" | 54½" | 58" |
| | Tooth Width | Teeth Width | Width |
| | 20" | Front 12" Back 20" (2, 3" wide teeth, 14" apart) | 36" |

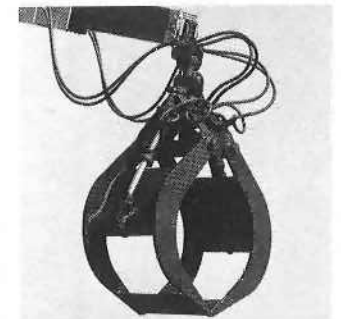

- Clam Bucket
- Model GPC
- Butt Grapple
- Model BTG
- Bypassing Grapple
- Model BPG

Pallet Fork

Turns your N-135 into a versatile, payload-packing fork lift. Great for delivering palletized materials where you want them. 4,400 pounds (1,996 kg) capacity with adjustable throat and teeth. Handles most loads with ease. Available with hydraulic leveling or with a manual slide collar for leveling. For extra versatility, specify a National Hydraulic Rotator.

- Capacity**4,400 lbs.
- Throat Opening**41" to 65" (adjustable)
- Tooth Length**38½"
- Tooth Width**33.5" to 57" (outside to outside) min. max.
- Weight**
 - MKF350 lbs.
 - HKF350 lbs.
 - HKFR450 lbs.

Model MKF

(Manual leveling, adjustable throat)

Model HKF

(Hydraulic leveling, adjustable throat)
Requires AH-1

Model HKFR

(Hydraulic leveling, adjustable throat with hydraulic rotator)
Requires AH2

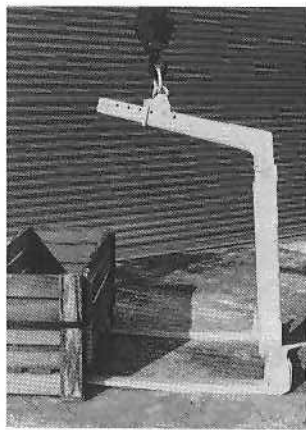

Winch

This extra-capacity, heavy-duty winch handles up to 4,400 pounds with a single part block and 8,800 pounds with a two-part block. Easy single-pin attachment of boom-tip sheave head. Includes winch control and the anti-two-block feature to prevent cable damage when winching up or extending the

boom without paying out the winch cable. The winch option reduces the capacities by approximately 200 pounds and eliminates the hook point on the outer section boom.

Model N5

- Line Pull**
 - 1st wrap5,300 lbs.
 - 2nd wrap4,800 lbs.
 - 3rd wrap4,400 lbs.
- Speed**
 - 1st wrap75 ft./min.
 - 2nd wrap84 ft./min.
 - 3rd wrap93 ft./min.

Cable

90 ft. of 7/16" rotation resistant cable.

Winch

7½" dia. drum, 11.62" dia. flange, 6.38" wide with safety brake. OSHA required 18:1 ratio drum diameter to cable diameter.

Sheaves

Run on roller bearings with OSHA required 18:1 ratio sheave diameter to cable diameter.

Controls

Includes hydraulic control valve and hoses to winch.

One Person Basket

This strong, lightweight fiberglass basket with 300-pound capacity puts personnel where you want them for the occasional tough maintenance and installation jobs. Easy on-off. Safety belts included. Gravity or lock-type leveling.

- Capacity**300 lbs.
- Weight**150 lbs.
- Dimensions**22" x 22" x 42"
- Construction**Fiberglass

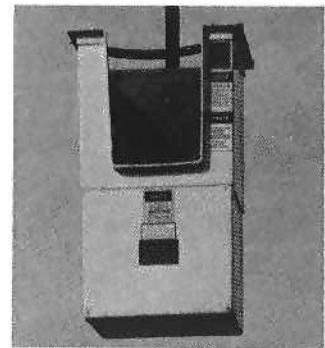

2 Models

B1, gravity hung without lock
B1-L, gravity hung with swing lock

Includes safety belt and lanyard. Cannot be used simultaneously with winch.

Model B1

Model B1-L
(with lock)

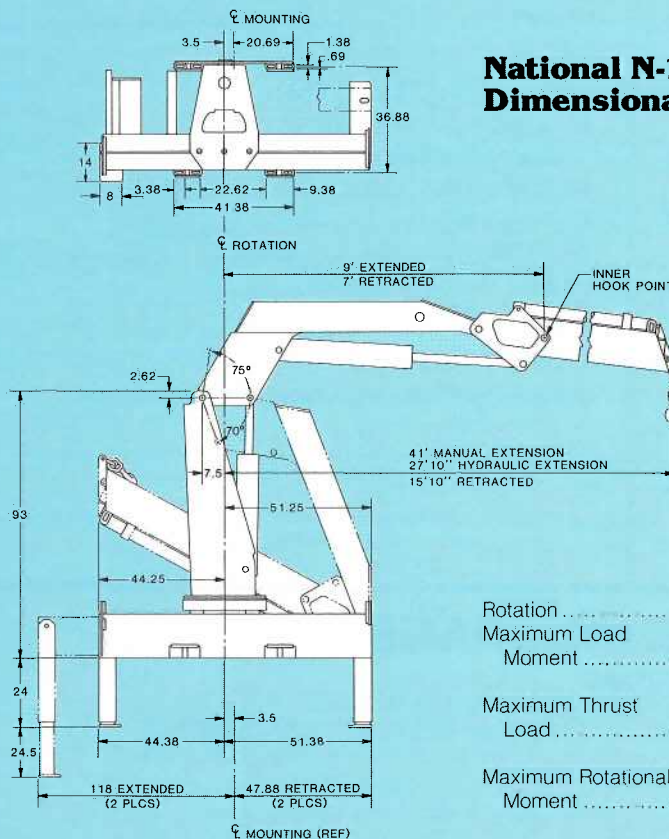

National N-135 Dimensional Specifications

- Rotation410° noncontinuous
- Maximum Load Moment161,000 foot/pounds at mounting surface
- Maximum Thrust Load25,000 pounds at mounting surface
- Maximum Rotational Moment14,750 foot/pounds

National N-135 Proposal



Date: _____

Prepared for: _____

Submitted by: _____

_____ (Firm Name)

_____ (Address)

_____ (City & State)

_____ (Zip)

_____ (Phone)

Signed: _____

Description

Basic N-135 N-135/28

N-135/41

Options/Accessories:

1. Optional controls

MR4 Remote

MR5 Remote

MR6 Remote

2. Auger AG135 Flighting: 9" 12" 15" 18"

3. Winch N5

4. Pallet Fork

2-Part Block

MKF Manual Leveling

HFK Hydraulic Leveling

MKFR Hydraulic Leveling

with Hydraulic Rotator

5. Grapples or Clam Bucket

BTG Butt

BPG Bypassing

GPC

6. Accessory Valves

AH1 Single Control

AH2 Dual Control

7. One Person Basket

8. Other _____

Mounting:

9. Installation Std. Spec.

10. Stability 180° 360°

11. Frame Reinforcing Weld Bolt-Extra

12. Platform Bed _____ ft Wood Steel

13. Weight in bed _____ lbs. (if required)

14. Chassis _____

15. Rear Bumper Protection _____

16. Back-up Alarm _____

17. Freight _____

This quotation will remain firm for _____ days.

Accepted by: _____

(Name)

(Title)

(Firm Name)

Date: _____

Price

\$ _____

\$ _____

\$ _____

\$ _____

\$ _____

\$ _____

\$ _____

\$ _____

\$ _____

\$ _____

\$ _____

\$ _____

\$ _____

\$ _____

\$ _____

\$ _____

\$ _____

\$ _____

\$ _____

\$ _____

\$ _____

\$ _____

\$ _____

\$ _____

\$ _____

\$ _____

\$ _____

Sub Total

\$ _____

Total Price



NATIONAL CRANE

General Offices

11200 North 148th Street/Waverly, NE 68462

Phone: 402-786-2240; Telex: 438061; Fax: 402-786-3636

Your National Dealer:

National reserves the right to change designs, prices and specifications at any time without notice.