

Specifications

Hydraulic Rough Terrain Crane

HSP-8035S

35 Ton (31.75 metric ton)

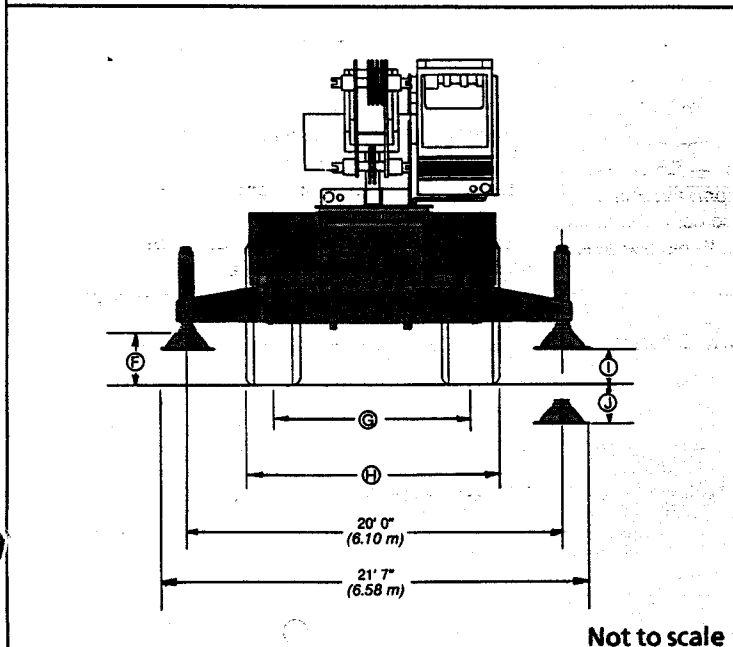
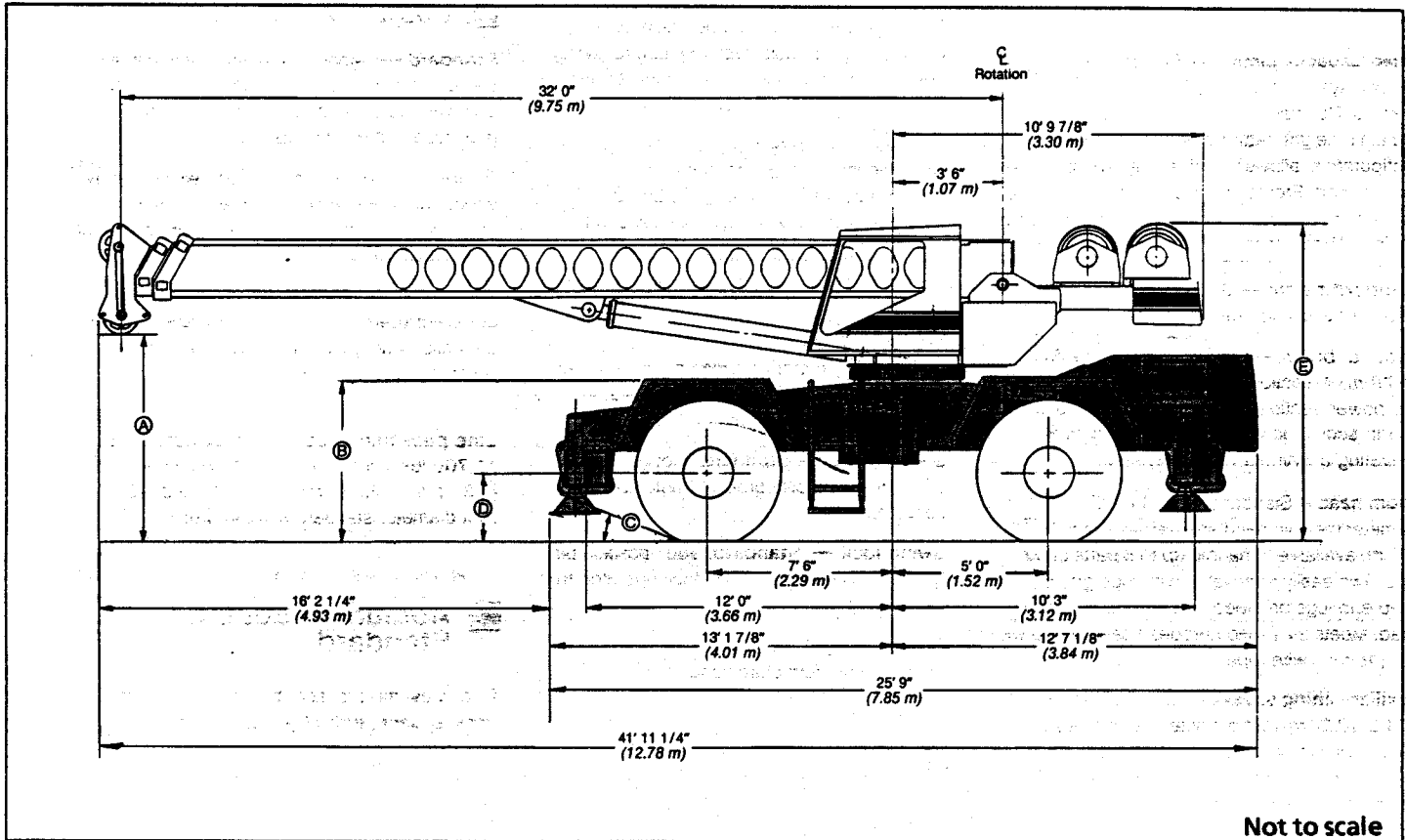

General dimensions	feet	meters
Turning radius (4-wheel steer)	19' 4"	5.89
Tailswing of counterweight:	11' 1"	3.38

Dimensions affected by tires

Tires	20.5 x 25 (24-PR)		23.5 x 25 (20-PR)	
	feet	meters	feet	meters
A	7' 3"	2.21	7' 5"	2.26
B	5' 9"	1.75	5' 10"	1.78
C	22.5"	—	24.4"	—
D	2' 3"	.68	2' 4"	.71
E	11' 6"	3.50	11' 8"	3.55
F	18.26"	.46	20.16"	.51
G	7' 6"	2.29	7' 5"	2.26
H	9' 3"	2.82	9' 5"	2.87
I	11.26"	.29	13.16"	.33
J	7.29"	.18	4.89"	.12

Upperstructure



Boom

Patented design. Boom side plates have diamond shaped impressions for superior strength to weight ratio and 100,000 psi (689.5 MPa) steel angle chord for lateral stiffness. Boom sections are supported by wear shoes both vertically and horizontally. Anti two block, electronic boom length/angle indicator and function kickout.

Rated Capacity Limiter — Standard; Audio-visual warning system with anti-two block and function kickouts. Constant display of boom length and angle, tip height, radius of load, machine configuration, allowed load, actual load and % of allowed load. Presettable alarms for maximum and minimum boom angles, maximum tip height and maximum boom length.

Standard boom — 32' 0" - 80' 0" (9.75 m - 24.38 m) 3-section full power boom.

Optional boom — 32' 0" - 101' 0" (9.75 m - 30.78 m) 4-section boom includes base section, two power sections, and manual fourth section. Fourth section is power pinned by manually activating a cylinder locking system.

Boom head — Standard; three 14-1/2" (.37 m) root diameter metallic head sheaves with four 14-1/2" (368 mm) available to handle up to 8 parts of wire rope. Two easily removable wire rope guards; rope dead end lugs provided on each side of boom head. Meets 24:1 ratio European safety code with 5/8" (16 mm) wire rope.

Auxiliary lifting sheave — *Optional*; Single 14-1/2" (0.37 m) root diameter metallic head sheave with removable wire rope guard, mounted to boom. For use with one or two parts of line off the optional auxiliary winch. Does not affect erection of fly or jib, or use of main head sheave for multiple reeving.

Boom elevation — One hydraulic cylinder with holding valve. Self-aligning steel bushings. Hand and optional foot controls for controlling the boom elevation from -3° to 80°.

Fly

Optional — 29' 0" (8.84 m) stowable one-piece lattice type with 2" offset.

Jib

Optional — 21' 0" (6.40 m) stowable A-frame. Can be offset 5°, 17.5°, and 30°. Attaches to fly only.

Cab and Controls

Environmental cab; isolated from sound and vibration by a neoprene seal. All windows are tinted and tempered safety glass. Sliding rear and right side windows and swing up roof window for maximum visibility and ventilation. Slide-by-door opens to 3'0" (0.91 m) width. 6-way adjustable operator's seat. 4-way adjustable tilt/telescoping steering wheel. Control levers for swing, boom telescope, winch and boom hoist with foot control swing brake. Outrigger controls, sight level bubble. Optional foot control for boom hoist.

Cab instrumentation

Dash mounted gauges for hydraulic oil temperature, converter temperature, oil pressure, water temperature, fuel and voltmeter.

Swing

Bi-directional hydraulic swing motor mounted to a planetary reducer for 360° continuous smooth swing at 2.05 r.p.m.

Swing brake — Standard; foot operated, spring released disc brake mounted on the speed reducer.

Swing lock — Standard; 360° position pin-type and two position travel lock operated from the operator's cab.

Counterweight

Bolted to upperstructure frame.

Hydraulic System

Main pump — Triple gear-type pump. Combined pump capacity 110 gpm (416.35 lpm). Powered by torque converter through a pump disconnect. Pump disconnect is a jaw-type clutch engaged/disengaged from carrier. Maximum system pressure at 2,900 p.s.i. (199.94 Bars).

Steering/outrigger pump — Single gear-type pump, 21 gpm (79.5 lpm) maximum capacity. Powered by torque converter through a straight mechanical drive. Pump operates at 2,500 p.s.i. (172.37 bars).

Reservoir

110 gallon (416.0 L) capacity. Diffusers for deaeration.

Filtration — One six-micron filter located inside of the hydraulic reservoir. Accessible for easy replacement.

Control valves — Six separate control valves allow simultaneous operation of all crane functions.

Load Hoist System

Standard — Model 2M main winch with two-speed motor and automatic brake; power up/power down mode of operation. Bi-directional gear type hydraulic motor.

Optional — Model 2M auxiliary winch with two-speed motor and automatic brake, power up/power down mode of operation. Bi-directional, gear-type hydraulic motor.

Optional — Model 3M winch with power up/power down, two-speed motor and exclusive controlled true gravity free fall. Available on main winch only.

Line pulls and speeds — Maximum line pull 11,700 lbs. (5 307 kg) and maximum line speed 413 f.p.m. (125.88 m/min.) on 10 5/8" (0.27 m) root diameter standard smooth drum.

Additional Equipment - Standard

Rear view mirrors, seat belt, fire extinguisher, backup alarm, travel lights and sound suppressed cab.

Additional Upperstructure Equipment - Optional

Propane, diesel or hydraulic heater, air conditioning, drum rotation indicators, 25-ton (22.68 metric ton) or 35-ton (31.75 metric ton) hook block, 8-1/2 ton (7.71 metric ton) hook ball and swivel, rear steer indicator, boom mounted working light, engine monitoring system, top hatch wiper, windshield washer, hand throttle, lifting lugs, tachometer, amber rotating beacon, cab spotlight, and boom hoist foot control.

Carrier

■ Type

9' 3" (2.82 m) wide, 150" (3.81 m) wheelbase.

4 x 4 x 4 — (4-wheel steer, 4-wheel drive) •

Standard; for rough terrain with limited turning area.

4 x 4 x 4 — (4-wheel steer, 4-wheel drive)

Optional; no spin differential on front axle; for rough terrain with limited turning area.

Frame - 100,000 p.s.i. (689.5 MPa) steel, double walled construction with integral 100,000 p.s.i. (689.5 MPa) steel outrigger boxes.

■ Axles

Front, Standard — heavy duty planetary drive/steer type.

Rear, Standard — heavy duty planetary drive/steer type.

Front, Optional — heavy duty no-spin high traction differential, planetary drive/steer type.

■ Suspension

Front axle — Rigid mounted to frame.

Rear axle — Pin-mounted on bronze bushings. Automatic hydraulic rear axle oscillation lock-out cylinders engage when upperstructure rotates past 2-1/2° of centerline.

■ Tires

Front and rear Standard — 20.5 x 25 (24-PR) Earthmover type

Optional — 23.5 x 25 (20-PR) Earthmover type

■ Brakes

Service — Air over hydraulic, drum-type brakes at each wheel end. Drum diameter 17-1/2" (0.44 m) Shoe width 4" (0.10 m).

Parking/emergency — Disc caliper type spring applied, air released, fade resistant; cab controlled, mounted on front axle.

■ Steering

Hydraulic two wheel, four wheel and "crab" steering.

■ Transmission

3-speed, 2-range power shift transmission. Six speeds available forward and 2 reverse. Front axle disconnect for two or four-wheel drive.

■ Outriggers

Four hydraulic, beam and jack outriggers. Vertical jack cylinders equipped with integral holding valve. Beams extend to 20' 0" (6.10 m) centerline-to-centerline and retract to within 9' 3" (2.82 m) overall width with floats stored. Equipped with stowable, lightweight 19" (0.48 m) diameter floats. Controls and sight level bubble located in upperstructure cab.

■ Additional Equipment - Standard

Cab steps, 2 front carrier steps, skid resistant finish on carrier deck, storage compartment and fenders.

■ Additional Equipment - Optional

Towing shackles, ether injection, no-spin differential on front axle, spare tires and rims, pintle hook, jack cylinder hose covers, propane fired engine block heater, air dryer, lifting lugs and emergency steering system.

Travel Speeds and Gradeability

Engine	Tires	Maximum Speed		Gradeability at stall	Maximum tractive effort at stall		Gradeability at 1.0 mph (1.61 km/h)	Maximum tractive effort at 1.0 mph (1.61 km/h)	
		mph	km/h		pounds	kg		pounds	kg
Cummins 6BT5.9	20.5 x 25	21.9	35.23	89.0%	40,396	18 324	50.6%	27,807	12 613
	23.5 x 25	22.8	36.68	78.9%	37,712	17 106	46.3%	25,960	11 775
Detroit Diesel 4-53T	20.5 x 25	21.6	34.79	84.0%	41,063	18 626	49.0%	28,298	12 835
	23.5 x 25	22.4	36.04	78.4%	38,335	17 338	45.7%	26,418	11 983

* Optional Equipment

Engine	Cummins 6BT5.9	Detroit Diesel 4-53T *
Cylinders - cycle	6-4	4-2
Bore	4.02" (.10 m)	3.875" (.10 m)
Stroke	4.72" (.12 m)	4 1/2" (.11 m)
Displacement	359.0 cu. in. (5 884 cm ³)	212 cu. in. (3 474 cm ³)
Maximum brake h.p.	152 @ 2500 r.p.m.	165 @ 2,500 r.p.m.
Peak torque	400 ft. lbs. (542 J)	412 ft. lbs. (559 J)
Electrical system	12 volt negative ground	12 volt negative ground
Fuel capacity	75 gal. (283 L)	75 gal. (283 L)
Alternator	80 amps	80 amps
Crankcase capacity	4.1 gal. (15.52 L)	4.0 gal. (15 L)
Air compressor	9.5 c.f.m. (.27 m ³ /min)	12 c.f.m. (.34 m ³ /min)

* Optional Equipment

Axle Loads

Base machine with standard 32'-80' (9.75 m-24.38 m) 3-section boom, main winch with 2-speed hoisting and power up/down, 450' (137.16 m) 5/8" (16 mm) wire rope, 4x4x4 carrier with Cummins 6BT5.9 engine, 20.5x25 tires, full fuel, counterweight, 3-sheave head machinery.	GVW [Ⓞ]		Upper facing front				Upper facing rear			
			Front axle		Rear axle		Front axle		Rear axle	
	lbs.	kg	lbs.	kg	lbs.	kg	lbs.	kg	lbs.	kg
	52,271	23 710	23,744	10 770	28,527	12 940	15,084	6 842	37,187	16 868
32' - 101' (9.57 m - 30.78 m) 4-section boom	3,120	1 415	2,891	1 311	229	104	-395	-179	3,515	1 594
Free fall main winch with 450' (137.16m) rope	140	63	-26	-12	166	75	138	63	2	1
Power up/down auxiliary winch with 350' (106.75 m) rope	620	281	108	49	512	232	388	176	232	105
29' (8.8 m) lattice fly stowed	1,080	490	1,334	605	-254	-115	-470	-213	1,550	703
21' (6.40 m) A-frame jib stowed	970	440	1,093	496	-123	-56	-317	-144	1,287	584
Hook block at bumper	650	295	884	401	-234	-106	—	—	—	—
Headache ball at bumper	325	148	441	200	-116	-52	—	—	—	—
Auxiliary lifting sheave	125	57	350	159	-225	-102	-250	-113	375	170
23.5 x 25 tires	112	51	56	25	56	25	—	—	—	—

[Ⓞ] Adjust gross vehicle weight and axle loading according to components weight.

Note: All weights are ± 3%.

Tire	Max. Axle Load @ 20 mph (32.7 km/hr)
20.50 x 25 (24-PR)	31,000 lbs. (14 060 kg)
23.50 x 25 (20-PR)	31,000 lbs. (14 060 kg)

• Link-Belt is a registered trademark.

We are constantly improving our products and therefore reserve the right to change designs and specifications.

Link-Belt Construction Equipment Company Lexington, Kentucky

A unit of Sumitomo Construction Machinery Co., Ltd.