

TADANO

TR-300E

33 Ton Capacity (30.0 metric tons)

HYDRAULIC ROUGH-TERRAIN CRANE

DIMENSIONS

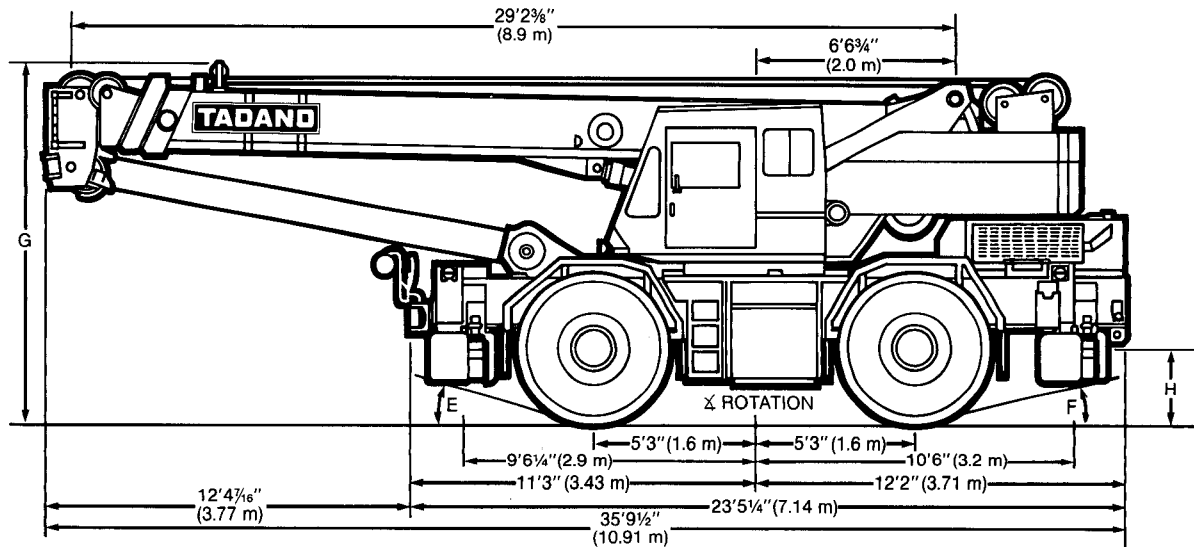

GENERAL DIMENSIONS

	Feet	Meters
Tail swing of counterweight	11'4 1/4"	(3.46 m)

DIMENSIONS AFFECTED BY TIRES

Tires	16.00 x 25	20.5 x 25
A	7'1/4" (2.14 m)	7'1/4" (2.14 m)
B	8'7 1/8" (2.62 m)	8'11 1/8" (2.74 m)
C	1'2 7/16" (0.366 m)	1'2 9/16" (0.37 m)
D	9 1/16" (0.23 m)	9 1/16" (0.23 m)
E	15.4°	15.6°
F	12.7°	12.8°
G	11'7 15/16" (3.555 m)	11'7 15/16" (3.56 m)
H	2'2 3/4" (0.68 m)	2'2 3/4" (0.68 m)
Turning Radius:		
4 wheel steer	19'8 1/4" (6.0 m)	19'8 1/4" (6.0 m)
2 wheel steer	33'9 1/2" (10.3 m)	33'9 1/2" (10.3 m)

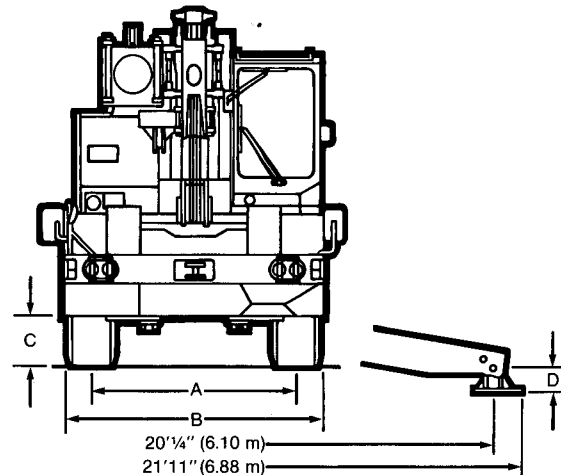

Crane Specifications

BOOM

Four section full power partially synchronized telescoping boom, 29.2' ~ 92.2' (8.9 ~ 28.1 m), of box construction with five sheaves, 13 $\frac{3}{8}$ " (0.352 m) root diameter, at boom head. The synchronization system consists of two telescope cylinders, an extension cable and a retraction cable. Hydraulic cylinders fitted with holding valves. Two easily removable wire rope guards, rope dead end provided on right side of boom head. Boom telescope sections are supported by wear pads both vertically and horizontally.

Boom elevation — Two double acting hydraulic cylinders with holding valve. Elevation 1°~80°, combination controls for hand or foot operation. Boom angle indicator.

Jib — Box type top section telescopes from lattice type base section which stores alongside base boom section. 5° or 30° offset (tilt type). Single sheave, 13 $\frac{3}{8}$ " (0.352 m) root diameter, at jib head. Jib length is 23' (7.0 m) or 39.4' (12.0 m).

Auxiliary Lifting Sheave (Single top) — Optional. Single sheave, 13 $\frac{3}{8}$ " (0.352 m) root diameter. Mounted to main boom head for single line work. (Stowable.)

Anti-Two Block — Pendant type over-winding cut out device with audio-visual (FAILURE lamp/BUZZER) warning system.

SWING

Hydraulic axial piston motor driven through planetary swing speed reducer. Continuous 360° full circle swing on ball bearing turntable at 3.2 rpm. Equipped with manually locked/released swing brake. A swing lock (pin-in-hole lock) for pick and carry and travel modes, manually engaged in cab.

HOIST

Main hoist — Variable speed type with grooved drum driven by hydraulic axial piston motor through winch speed reducer. Power load lowering and raising. Equipped with automatic brake (neutral brake) and counterbalance valve. Controlled independently of auxiliary hoist.

Drum — Grooved 12 $\frac{5}{8}$ " (0.320 m) root diameter x 21 $\frac{1}{8}$ " (0.5356 m) wide. Wire rope: 525 ft. of $\frac{5}{8}$ " diameter rope (160 m of 16 mm). Drum capacity: 810 ft. (246.8 m) 6 layers. Maximum line pull (permissible): 8,833 lbs. (4007 kgs)*. Maximum line speed: 430 FPM (131 m/min).

Auxiliary hoist — Optional. Variable speed type with grooved drum driven by hydraulic axial piston motor through winch speed reducer. Power load lowering and raising. Equipped with automatic brake (neutral brake) and counterbalance valve. Controlled independently of main hoist.

Drum — Grooved 12 $\frac{5}{8}$ " (0.320 m) root diameter x 21 $\frac{1}{8}$ " (0.5356 m) wide. Wire rope: 295 ft. of $\frac{5}{8}$ " diameter rope (90 m of 16 mm). Drum capacity: 810 ft. (246.8 m) 6 layers. Maximum line pull (permissible): 8,833 lbs. (4007 kgs)*. Maximum line speed: 430 FPM (131 m/min).

Wire rope — Filler wire, extra improved plow steel, preformed, independent wire rope core, right regular lay.

$\frac{5}{8}$ " (16 mm) 6 x 37 class

$\frac{5}{8}$ " (16 mm) 19 x 7 class

19 x 7 is non-spin rope intended for single line work and is not recommended for multiple part reeving.

Hook blocks — Optional

1. 33 Ton (30 metric tons) — 5 sheaves with swivel hook and safety latch, for $\frac{5}{8}$ " (16 mm) wire rope.
2. 3.3 Ton (3.0 metric tons) — Weighted hook with swivel and safety latch, for $\frac{5}{8}$ " (16 mm) wire rope.

HYDRAULIC SYSTEM

Pumps — Triple gear pump for crane. Tandem gear pump for steering and optional equipment. Powered by carrier engine. Pump disconnect for crane is engaged/disengaged by rotary switch from operator's cab.

Control valves — Multiple valves actuated by hand levers with integral pressure relief valves.

Reservoir — 111 gallon (421 lit.) capacity. External sight level gauge.

Filtration — 10 micron return line filter, located on superstructure.

Oil Cooler — Air cooled fan type.

CAB AND CONTROLS

Both crane and drive operations can be performed from one cab mounted on rotating superstructure.

One sided 1 man type, steel construction with sliding door access and safety glass windows opening at side, rear and roof. Windshield glass is shatter-resistant. Adjustable-control levers for swing, boom telescope, boom hoist, auxiliary hoist and main hoist (with swing free-lock selector switch). Engine throttle knob. Foot operated controls: boom hoist, service brake and engine throttle.

Dash-mounted engine start/stop, monitor lamps, electronic working condition indicator with boom length/angle, radius/hook height and rated loads/actual loads indication, pump engaged/disengaged switch, working condition select switches, cigarette lighter, windshield wiper switch, steering mode select switch, exhaust brake switch and drum rotation indicator.

Operator's cab console includes transmission gear selector, working condition indicator select switch, outrigger controls, sight level bubble, rear steering lock switch, drive selector switch, working light switch, ashtray and parking brake selector. Swing lock knob, swing brake and reclining seat with high back (with seat belt).

Instruments — Engine water temperature, air pressure, fuel, speedometer, hydraulic oil pressure, torque converter oil temperature, tachometer and hourmeter.

*Maximum permissible line pull may be affected by wire rope strength.

Carrier Specifications

Type — Rear engine, left hand steering, driving axle 2-way selected type by manual switch. 4 x 2 front drive, 4 x 4 front and rear drive.

Frame — High-tensile steel, all welded box construction.

Transmission — Torque converter (with automatic lock up device at forward, 3rd and 4th) driving full powershift with driving axle selector. 4 forward and 1 reverse speeds, constant mesh.

Travel Speed — 31.2 mph maximum.

Axle — *Front*: Full floating type, steering and driving axle with planetary reduction. *Rear*: Full floating type, steering and driving axle with planetary reduction. No-spin differential.

Steering — Hydraulic power steering controlled by steering wheel. Three steering modes available: 2 wheel front, 4 wheel coordinated, and 4 wheel crab.

Suspension — *Front*: Semi-elliptic leaf springs with hydraulic lockout device. *Rear*: Semi-elliptic leaf springs with hydraulic lockout device.

Brake Systems — *Service*: Dual line air operated internal expanding brakes to all 4 wheels.

Parking/emergency: Spring operated air released brake acting on input shaft of front axle.

Tires — *Front*: Standard 16.00 x 25 — 24 PR (OR), optional 20.50 x 25 — 20 PR (OR)
Rear: Standard 16.00 x 25 — 24 PR (OR), optional 20.50 x 25 — 20 PR (OR)

Outriggers — Hydraulically operated. Double box construction. Extended in "X" configuration. Integral with carrier frame. Power in and out, up and down. Provided with pilot check valves. Each outrigger slider beam and jack is controlled independently from the cab. Fully extended to 20'½" (6.1 m) and retract to within 8'7½" (2.62 m) overall width. Controls and sight level bubble located in upperstructure cab.

ENGINE

Model	MITSUBISHI 6D22	Radiator	Fin and tube core, thermostat controlled
Type	Direct Injection Diesel	Fan, in. (mm)	6 blade, blower type, 25.6 (650) dia.
No. of cylinders	6	Starting	24 volt motor
Combustion	4 cycle, naturally aspirated	Charging	24 volt system, negative ground
Bore x stroke, in. (mm)	5.118 x 5.512 (130 x 140)	Battery	2 — 140 amp hour
Displacement, cu. in. (liters)	680 (11.149)	Compressor, air, CFM (LPM)	14.9 CFM (420 LPM) at 2,000 rpm
Air inlet heater	24 volt preheat	Horsepower, HP (KW)	Gross 190 (139) at 2300 rpm Net 180 (134) at 2300 rpm
Air cleaner	Dry type, replacement element (dual)	Torque, Max., ft.-lb. (kgm)	463 (64) at 1400 rpm
Oil filter	Fullflow with replacement element	Capacity, gal. (liters)	
Fuel filter	Fullflow with replacement element	Cooling water	5.8 (22)
Fuel tank, gal. (liters)	79.2 (300), right side of carrier	Lubrication	6.3 ~ 7.7 (24 ~ 29)
Cooling	Liquid pressurized, recirculating by-pass		

AXLE WEIGHT DISTRIBUTION CHART

ITEM	POUNDS			KILOGRAMS		
	G.V.W.	FRONT	REAR	G.V.W.	FRONT	REAR
Basic standard machine to include: 29.2' ~ 92.2' (8.9 m ~ 28.1 m) 4 section boom; 23' ~ 39.4' (7.0 m ~ 12.0 m) 2-stage jib; main hoist with 525' (160 m) of ½" (16 mm) diameter rope; 33 ton (30 metric ton) hookblock; 3.3 ton (3 metric ton) hookball; 3,494 lbs. (1585 kgs) counterweight; Mitsubishi 6D22 engine, 16.00 x 25-24 PR tires.	57,518	28,731	28,787	26,090	13,032	13,058
ADD: Auxiliary hoist with 295' (90 m) of ½" (16 mm) wire rope 2,200 lbs. (1000 kgs) counterweight Auxiliary lifting sheave (single top)	+1,398 +2,200 +121	-326 -1,170 +320	+1,724 +3,370 -199	+634 +1,000 +55	-148 -531 +145	+782 +1,531 -90
SUBSTITUTE: 20.50 x 25-20 PR tires with fenders	+688	+344	+344	+312	+156	+156
REMOVE: 23.0' ~ 39.4' (7.0 m ~ 12.0 m) 2-stage jib 33 ton (30 metric ton) hookblock 3.3 ton (3 metric ton) hookblock 3,494 lbs. (1585 kgs) counterweight	-1,323 -770 -110 -3,494	-2,266 -960 +62 +1,856	-943 +190 -172 -5,350	-600 -350 -50 -1,585	-1,028 -436 +28 +842	+428 +86 -78 -2,427

3,494 lbs. (1585 kgs) counterweight used with main hoist only.
 2,200 lbs. (1000 kgs) counterweight used with main hoist and auxiliary hoist.

Standard Equipment

- Four section full power partly synchronized boom 29.2' - 92.2' (8.9 m - 28.1 m)
- Two stage stowable telescoping jib 23' (7.0 m) or 39.4' (12.0 m) with 5° or 30° pinned offset (tilt type)
- Boom hoist foot control
- Boom angle indicator
- Variable speed main hoist driven by axial piston motor with drum rotation indicator and cable
- Tadano twin swing system
- 4 x 4 x 4 drive
- Hydraulic lock out suspension system
- Independently controlled outriggers
- Self-storing outrigger pads
- Full powershift transmission driven by torque converter
- Complete highway light package
- Anti two block device (Overwind cutout)
- Front windshield wiper and washer
- Roof windshield wiper
- Rear view mirrors (right and left side)
- Seat belt
- Back up alarm
- Low oil pressure/High water temperature warning device (visual)
- Fenders
- Air cleaner dust indicator
- Towing hooks — front and rear
- Lifting eyes
- Tool storage compartment
- Electronic crane monitoring system
- Electronic working condition indicator system including:
 - Load weight indicator - rated and actual
 - Boom length indicator
 - Boom angle indicator
 - Load radius indicator
 - Hook height indicator
- Full instrumentation package
- Pump disconnect in operator's cab
- Non-spin rear differential
- Flood lights
- Cable follower
- Hydraulic oil cooler
- Outrigger hose protection
- 24 volt electric system

Optional Equipment

- Variable speed auxiliary hoist with drum rotation indicator
- Auxiliary lifting sheave (single top) stowable
- 33 ton (30 metric ton) 5 sheave hook block
- 3.3 ton (3 metric ton) hook ball and swivel
- Heater
- Optional tires
- Fire extinguisher

Hoisting Specifications

LINE SPEEDS AND PULLS

Layer	Speed	Main or auxiliary hoist — 12% (0.32 m) drum					
		Line speeds ②		Line pulls			
				Available ①		Permissible ④	
		F.P.M.	m/min.	Lbs.	kgfs	Lbs.	kgfs
1st	Low	146	44.5	9715	4407	8833	4007
	High	292	89				
2nd	Low	159	48.5	9124	4139	8295	3763
	High	318	97				
3rd	Low	174	53	8395	3808	7632	3462
	High	348	106				
4th	Low	187	57	7773	3526	7067	3206
	High	374	114				
5th	Low	201	61.5	7235	3282	6578	2984
	High	403	123				
6th ③	Low	215	65.5	6770	3071	6155	2792
	High	430	131				

① Developed by machinery with first layer of wire rope, but not based on rope strength or other limitation in machinery or equipment.

② Line speeds based on only hook block, not loaded.

DRUM WIRE ROPE CAPACITIES

Wire rope layer	Main and auxiliary drum grooved lagging			
	% (16 mm) wire rope			
	Rope per layer		Total wire rope	
	Feet	Meters	Feet	Meters
1	108.9	33.2	108.9	33.2
2	119.4	36.4	228.3	69.6
3	129.6	39.5	357.9	109.1
4	140.1	42.7	498.0	151.8
5	150.6	45.9	648.6	197.7
6	161.1	49.1	809.7	246.8

DRUM DIMENSIONS

	Inch	mm
Root diameter	12%	320
Length	21%	535.6
Flange diameter	20%	530

③ Sixth layer of wire rope is not recommended for hoisting operations.

④ Permissible line pull may be affected by wire rope strength.

Working Radius — Lifting Height Diagram

BOOM

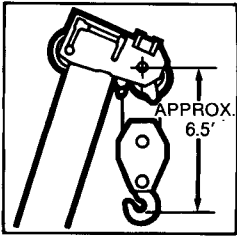

JIB

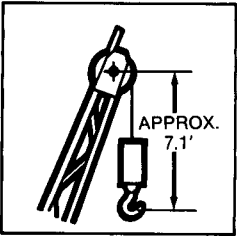

SINGLE TOP

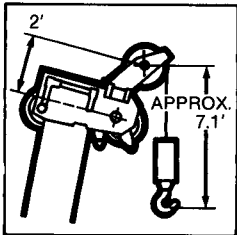

NOTE: Boom and jib geometry shown are for unloaded condition and machine standing level on firm supporting surface. Boom deflection and subsequent radius and boom angle change must be accounted for when applying load to hook.

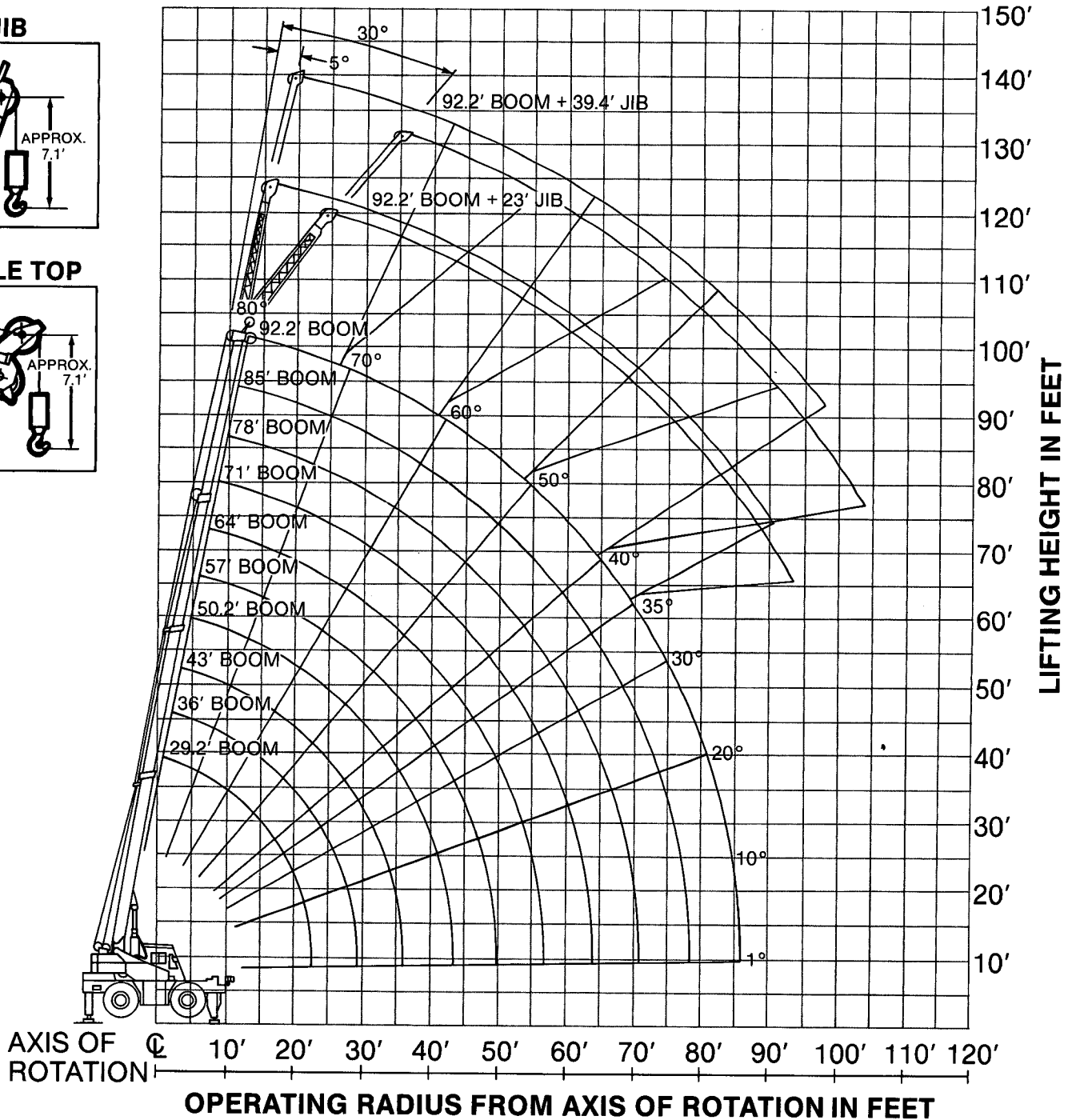

LIFTING HEIGHT IN FEET

AXIS OF ROTATION 10' 20' 30' 40' 50' 60' 70' 80' 90' 100' 110' 120'

OPERATING RADIUS FROM AXIS OF ROTATION IN FEET

Lifting Capacities

Work- ing Radius (Feet)	360° Rotation																	
	Boom Length in Feet																	
	∠°	29.2'	∠°	36'	∠°	43'	∠°	50.2'	∠°	57'	∠°	64'	∠°	71'	∠°	78'	∠°	85'
10'	62°	66,100	67°	53,300	72°	47,400	75°	42,300	77°	33,000								
12'	57°	52,900	64°	48,500	69°	46,000	72°	42,300	75°	33,000	77°	27,500	78°	22,700				
15'	49°	45,300	58°	41,800	64°	40,000	68°	38,100	71°	33,000	74°	27,500	76°	22,700	77°	19,800	78°	18,000
20'	31°	34,100	47°	32,100	56°	30,800	62°	30,000	66°	27,000	69°	25,100	71°	22,300	73°	19,800	75°	18,000
25'			34°	24,700	47°	23,600	55°	22,900	60°	22,000	64°	20,300	67°	18,800	69°	17,200	72°	15,900
30'					36°	17,400	47°	16,900	54°	16,900	58°	16,500	62°	15,900	65°	14,400	68°	13,500
35'					17°	13,400	38°	12,900	47°	12,700	53°	13,100	58°	12,900	61°	12,200	64°	11,700
40'							26°	9,700	39°	10,100	47°	10,600	52°	10,400	57°	10,200	60°	10,100
45'									29°	8,300	39°	8,600	47°	8,600	52°	8,700	56°	8,500
50'									13°	6,700	31°	7,000	41°	7,100	47°	7,300	52°	7,400
55'											19°	5,600	33°	5,800	41°	6,000	47°	6,100
60'													24°	4,800	35°	5,000	42°	5,100
65'															27°	4,000	36°	4,100
70'															17°	3,300	29°	3,500
75'																	19°	2,800
80'																		
85'																		

NOTES

∠° = Degrees.

Boom Angles are in degrees.

Standard number of part lines should be according to the following table.

Boom Length in Feet (meters)	29.2' (8.9)	29.2' to 43' (8.9 to 13.1)	43' to 57' (13.1 to 17.4)	57' to 92.2' (17.4 to 28.1)	Single Top Jib
No. of part lines	10	8	6	4	1

The WORKING CONDITION INDICATOR stores the lifting capacity data based on the standard number parts of line listed in the chart.

NOTE: Before operating crane, refer to WARNING AND OPERATING INSTRUCTIONS for using the Working Condition Indicator.

Warning And Operating Instructions For

GENERAL

- Total rated loads shown on the TOTAL RATED LOAD CHART apply only to the machine as originally manufactured and normally equipped by TADANO LTD. Modifications to the machine or use of optional equipment other than that specified can result in a reduction of capacity.
- Construction equipment can be dangerous if improperly operated or maintained. Operation and maintenance of this machine must be in compliance with the information in the operation, safety and maintenance manual supplied with the machine. If this manual is missing, order replacement through the distributor.
- The operator and other personnel associated with this machine shall fully acquaint themselves with the latest applicable American National Standards Institute (ANSI) safety standards for cranes.

SET UP

- Total rated loads shown on the chart are the maximum allowable crane capacities and are based on the machine standing level on firm supporting surface under ideal job conditions. Depending on the nature of the supporting surface, it may be necessary to have structural supports under the outrigger floots or tires to spread the load to a larger bearing surface.
- For outrigger operation, outriggers shall be fully extended with tire free of supporting surface before operating crane.

OPERATION

- Total rated loads with outriggers fully extended do not exceed 85% of the tipping loads as determined by SAE Crane Stability Test Code J-765.

- Total rated loads above bold lines in the chart are based on crane strength and those below, on its stability. They are based on actual load radius increased by boom deflection.
- Total rated loads include the weight of main hook block (770 lbs. for 33 tons capacity), auxiliary hook ball (110 lbs. for 3.3 tons capacity), sling and auxiliary lifting devices and their weights shall be subtracted from the listed capacities to obtain the net load to be lifted.
- Total rated loads are based on freely suspended loads and make no allowance for such factors as the effect of wind, sudden stopping of loads, supporting surface conditions, inflation of tires, operating speeds, side loads, etc. Side pull on boom or jib is extremely dangerous.
- Total rated loads do not account for wind on lifted load or boom. Total rated loads and boom length shall be appropriately reduced, when wind velocity is above 20 mph (9m/sec.).
- Total rated loads at load radius shall not be exceeded. Do not tip the crane to determine allowable loads.
- Do not operate at boom lengths, beyond radii or boom angle, where no capacities are shown. Crane may overturn without any load on the hook.
- When boom length is between values listed, refer to the total rated loads of the next longer and next shorter booms for the same radius. The lesser of the two total rated loads shall be used.
- When making lifts at a load radius not shown, use the next longer radius to determine allowable capacity.

On Outriggers

Working Radius (Feet)	360° Rotation	
	Boom Length in Feet	
	∠°	92.2'
10'		
12'		
15'		
20'	77°	16,500
25'	73°	14,900
30'	70°	12,900
35'	67°	11,300
40'	63°	9,700
45'	59°	8,400
50'	56°	7,700
55'	52°	6,300
60'	47°	5,300
65'	43°	4,400
70'	37°	3,700
75'	32°	3,000
80'	23°	2,500
85'	11°	2,000

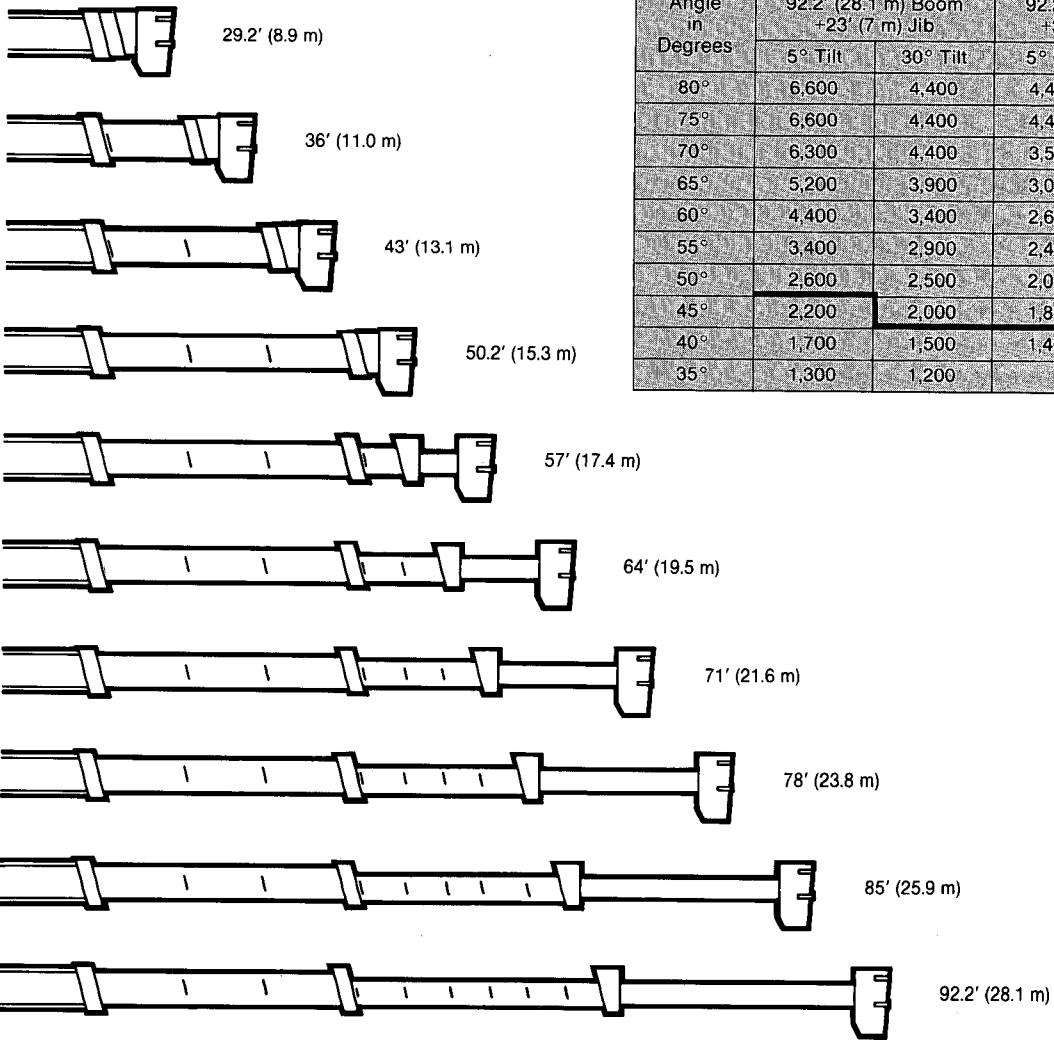

Boom Angle in Degrees	Boom Length in Feet			
	92.2' (28.1 m) Boom + 23' (7 m) Jib		92.2' (28.1 m) Boom + 39.4' (12 m) Jib	
	5° Tilt	30° Tilt	5° Tilt	30° Tilt
80°	6,600	4,400	4,400	2,200
75°	6,600	4,400	4,400	2,200
70°	6,300	4,400	3,500	1,900
65°	5,200	3,900	3,000	1,800
60°	4,400	3,400	2,600	1,700
55°	3,400	2,900	2,400	1,600
50°	2,600	2,500	2,000	1,500
45°	2,200	2,000	1,800	1,400
40°	1,700	1,500	1,400	1,200
35°	1,300	1,200		

Lifting Capacities

- Single line operation should not exceed 6600 lbs.
- Loaded boom angles are approximate. The boom angle before loading should be greater to account for deflection.
- The 29.2' (8.9 m) boom length capacities are based on boom fully retracted. If not fully retracted (less than 36' [11.0 m] boom length), use the total rated loads for the 36' (11.0 m) boom length.
- Extension or retraction of the boom with loads may be attempted within the limits of the TOTAL RATED LOAD chart. The ability to telescope loads is limited by hydraulic pressure, boom angle, boom length, crane maintenance, etc.
- For lifting capacity of single top, reduce 550 lbs. (250 kgs) from the total rated loads of relevant boom. Capacities of single top shall not exceed 6600 lbs. (3000 kgs) including main hook.
- When erecting and stowing jib, be sure to retain it by hand or by other means to prevent its free movement.
- 3300 lbs. (1500 kgs) shall be subtracted from the total rated loads of the main boom, when jib is attached to main boom head. Jib weight is 1320 lbs. (600 kgs).
- Use Anti-Two Block (OVERWIND CUTOUT) disable switch when erecting and stowing the jib and when stowing the hook block. While the switch is pushed, the hoist does not stop, even when overwind condition occurs.
- For boom lengths with 23' (7 m) Jib, total rated loads are determined by loaded boom angle only in the column headed "92.2' (28.1 m) Boom + 23' (7 m) Jib". For boom lengths with 39.4' (12 m) Jib, total rated loads are determined by loaded boom angle only in the column headed "92.2' (28.1 m) Boom + 39.4' (12 m) Jib". For angles not shown, use the next lower loaded boom angle to determine allowable capacity.
- When lifting a load by using jib (auxiliary hoist) and boom (main hoist) simultaneously, do the following:
 - Set BOOM SELECT switch to position corresponding to actual operating conditions, "JIB".
 - Before starting operation, make sure that the weight of load is within the total rated load for jib.

DEFINITIONS

- Load Radius:** Horizontal distance from a projection of the axis of rotation to supporting surface before loading to the center of the vertical hoist line or tackle with load applied.
- Loaded Boom Angle:** The angle between the boom base section and the horizontal, after lifting the total rated load at the load radius.
- Working Area:** Area measured in a circular arc about the centerline of rotation.
- Freely Suspended Load:** Load hanging free with no direct external force applied except by the hoist line.
- Side Load:** Horizontal side force applied to the lifted load either on the ground or in the air.

Lifting Capacities On Rubber

Boom Sequencing Diagram
Max. Permissible Boom Length in Feet

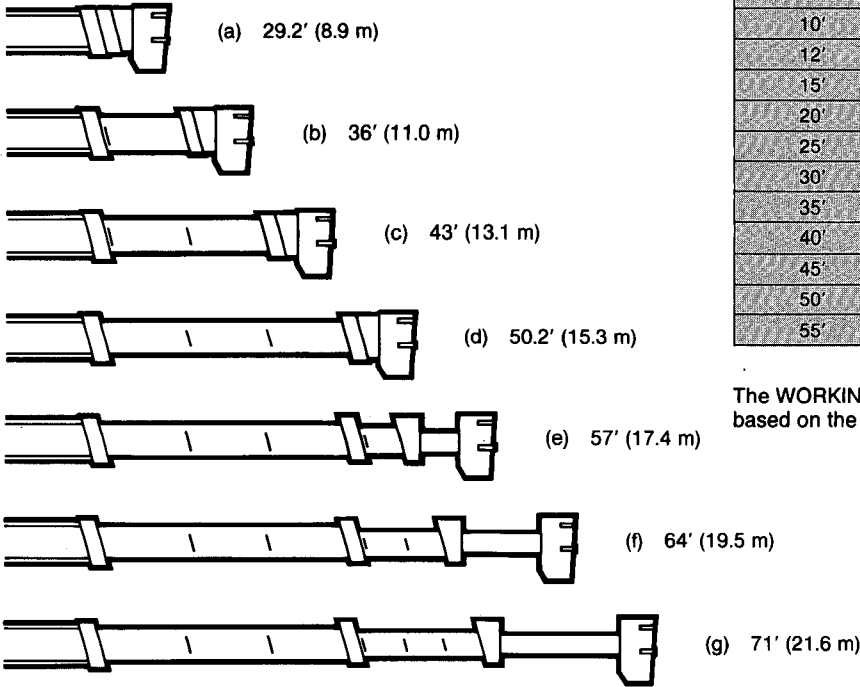

Working Radius in Feet	Stationary		Creep
	Over Front	360° Rotation	Over Front
10'	30,800 (a)	19,400 (a)	19,800 (a)
12'	29,700 (a)	14,700 (b)	18,900 (a)
15'	22,000 (a)	10,300 (b)	15,800 (b)
20'	13,300 (b)	5,500 (c)	11,900 (b)
25'	8,600 (c)	2,900 (g)	8,200 (c)
30'	5,900 (g)	1,700 (g)	5,900 (g)
35'	4,100 (g)	1,200 (g)	4,100 (g)
40'	2,700 (g)		2,700 (g)
45'	2,200 (g)		2,200 (g)
50'	1,400 (g)		1,400 (g)
55'	1,200 (g)		1,200 (g)

The WORKING CONDITION INDICATOR stores the lifting capacity data based on the standard number parts of line listed in the chart.

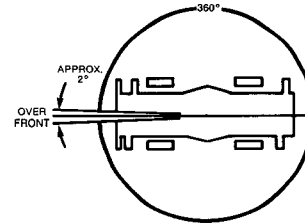

Warning And Operating Instructions For On Rubber Capacities

- Total rated loads on rubber are in pounds and do not exceed 75% of tipping loads as determined by test in accordance with SAE J-765.
- Total rated loads shown in the chart are based on condition that crane is set on firm level surface with suspension lock applied. Those above bold lines are based on tire capacity and those below, on crane stability. They are based on actual load radius increased by tire deformation and boom deflection.
- Total rated loads are based on proper tire inflation, capacity and condition. Damaged tires are hazardous to safe operation of crane.
- Tires shall be inflated to correct air pressure.

Tires	Air Pressure
16.00-25-24PR	96 psi (6.75 kgf/cm ²)
20.50-25-20PR	80 psi (5.6 kgf/cm ²)

- Over front operation shall be performed within two degrees in front of chassis.
- On rubber liftings with "jib" and "auxiliary lifting sheave" (single top) are not permitted. Maximum permissible boom length is 71 feet (21.6 m).
- When making lift on rubber, set parking brake.
- For creep operation, boom must be centered over front of machine, swing lock engaged, and load restrained from swinging. Travel slowly and keep the lifting load as close to the ground as possible, and especially avoid any abrupt steering, accelerating or braking.
- Do not operate the crane while carrying the load.
- Creep is motion for crane not to travel more than 200 feet (60 m) in any 30 minute period and to travel at the speed of less than 1 mph (1.6 km/h).

Warning And Operating Instructions For Using The Working Condition Indicator

- When operating crane on outriggers:
 - Set P.T.O. switch to "ON".
 - Set OUTRIGGER SELECT switch to "FULL (On O/R)".
 - Set BOOM SELECT switch to position corresponding to actual operating conditions.
- When operating crane on rubber:
 - Lock suspension springs with boom over front and crane in traveling configuration.
 - Set P.T.O. switch to "ON".
 - Set BOOM SELECT switch to "BOOM".
 - Set OUTRIGGER SELECT switch to position corresponding to actual operating conditions, in "On Rubber" range. However, pay attention to the following.
 - For Stationary Operation**
The front capacities are attainable only when OUTRIGGER SELECT switch is set to "FRONT" and "FRONT" indicator lamp is on. When boom is out of two degrees in front of chassis, "360°" indicator lamp is on and 360° capacities are effective.

When a load is lifted in the front position and then swung to the side area, be sure to set OUTRIGGER SELECT switch to "360°" in advance, and make sure that the value of WORKING CONDITION INDICATOR is below lifting capacity.

- For Creep Operation**
When OUTRIGGER SELECT switch is set to "Creep" and boom is in the straight forward position of chassis, "FRONT" indicator lamp flickers and creep capacities are attainable. If boom is not in the straight forward position of chassis, never lift load.
- During crane operation, make sure that the displays on front panel are in accordance with actual operating conditions.
 - The displayed values of WORKING CONDITION INDICATOR are based on freely suspended loads and make no allowance for such factors as the effect of wind, sudden stopping of loads, supporting surface conditions, inflation of tires, operating speeds, side loads, etc.

For safe operation, it is recommended when extending and lowering boom or swinging, lifting loads shall be appropriately reduced.

Specifications subject to change without notice. The equipment described in this catalog may contain options. Standard equipment may vary depending upon regulations and requirements of destination country.

TADANO
HYDRAULIC CRANES

SIMS CRANE & EQUIPMENT CO.
POST OFFICE BOX 11825
1219 U.S. HWY 301 NORTH
TAMPA, FLORIDA 33680
(813) 626-8102

Subsidiary of **MITSUBISHI CORPORATION**
Machinery Distribution, Inc.
247 McCarty Drive
Houston, Texas 77029
Telephone: (713) 675-6000
Telex: 203 392 MDI UR