

14127 CAS
Unit.



NATIONAL CRANE

A Grove Worldwide Company

11200 NORTH 148TH STREET, WAVERLY NE 68462 402-786-6300

SERIES 1400

**HYDRAULIC
CRANE
33 TON**

**LOAD
RATINGS**

! DANGER

**AN UNTRAINED OPERATOR
SUBJECTS HIMSELF AND
OTHERS TO
DEATH OR SERIOUS INJURY
YOU MUST NOT OPERATE
THIS CRANE UNLESS**

- You have been trained in the safe operation of this crane.
- You read, understand and follow the safety and operating recommendations contained in the crane manufacturer's manuals, your employers work rules and applicable government regulations.
- You are sure that all safety signs, guards and other safety features are in place and in proper condition.

⚠ DANGER**GENERAL**

1. This equipment can be hazardous if improperly maintained or operated. Read and comply with the Operator's Manual supplied with this machine for information on safety, operation and maintenance before operating this machine. If these manuals are missing, order replacements from National Crane through the distributor.
2. Rated loads shown on the capacity chart pertain to this machine as originally manufactured and equipped. Modifications to the machine or use of equipment that is not factory specified or approved can be hazardous. Refer to capacity deduction chart for weights which must be deducted from rated loads when accessories are attached to boom or loadline.

SET-UP

1. Inspect vehicle and crane including crane operation prior to use each day.
2. Load ratings shown on the appropriate charts are maximum allowable loads with the crane mounted on a factory approved truck and all outriggers at either full span or at mid span range and set on a firm level surface so the crane is level and the tires are suspended. This machine is not rated for use without outriggers. All outriggers must be extended equally - Mid span must be pinned. This machine is not rated for use with outriggers retracted.
3. Depending on the nature of the supporting surface, structural supports under the outrigger floats may be necessary to spread the load to a larger bearing surface.
4. Always level the crane with the level indicator located at each outrigger control station.

OPERATION

1. Operation of this equipment in excess of maximum load rating and disregard of instructions is hazardous. Always refer to the capacity chart for load and area limits before operating the crane. Rated loads at rated radius shall not be exceeded. Overloading this crane may cause structural collapse or instability.
2. Use the LMI/angle indicator as a reference only. When lifting maximum loads, measure radius and be certain of load weight.
3. Full extended outrigger rated loads do not exceed 85% of the tipping load as determined by SAE Crane Stability Test Code J765a when mounted on a factory recommended truck. Mid span outrigger stability loads are determined per ISO 4305, 1991. Structurally limited ratings on the capacity chart are shaded. Stability limited loads are not shaded. Machine will not always tip before structural damage occurs.

4. Rated loads include the weight of the hook block, slings, and other lifting devices. Their weights must be subtracted from the listed rated load to determine the net load that can be lifted.
5. Rated loads must be reduced when lifting at the boom tip with a jib stowed or erected. Refer to the chart labeled "Rated Load Reductions with Jib" for the reduction at each boom length.
6. Rated loads are based on freely suspended loads. Always position the boom tip directly over the load before lifting. No attempt shall be made to push down with the boom or move the load sideways in any direction by pulling or dragging the load.
7. The user shall operate at reduced ratings to allow for adverse job conditions such as soft or uneven ground, high winds or erratic operation which produce swinging (side) loads, experience of personnel, two machine lifts, or other hazardous conditions for safe operation.
8. Rated loads account for wind to 20 MPH on the boom capacities and to 15 MPH on jib capacities. Above these wind velocities, loads and/or boom lengths must be appropriately reduced for safe operation.
9. Do not operate at any radii beyond stability limit line on range chart. At these positions, the machine can overturn without any load on the hook.
10. When boom length or radius or both are between points listed on capacity chart, the smallest load shown at either the next larger radius or boom length shall be used.
11. Do not exceed jib capacities at any reduced boom length.
12. It is safe to telescope or retract any load listed if rating is not exceeded. Boom must be fully retracted against boom stops at all times when lifting minimum boom length capacity loads.
13. Always pay out loadline before extending boom to avoid damaging loadline or crane structure.
14. Loads lifted must be within safe winch capacity as well as safe crane capacity. Multiple part rope reeving must be used on loads exceeding winch single part rated pull. Auxiliary boom head and jibs are rated for single part use only.
15. Do not operate the boom over personnel or allow them to walk or stand beneath the boom or load.
16. Do not allow personnel on carrier deck, or crane frame area when rotating crane.

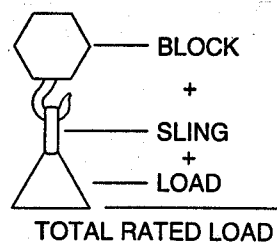

17. Do not allow personnel to ride on hook, hook block, load or any device attached to the loadline. Handling of personnel is only permitted with full extension of all outrigger beams. Use only National Crane approved baskets.
18. Operate controls slowly and smoothly to avoid damage to crane or personnel.
19. Boom must be in carrying rack and outriggers fully retracted for travel.
20. Maintain a clearance of at least 10 feet between any part of the crane, loadline or load and any electrical line carrying up to 50,000 volts. One foot additional clearance is required for every additional 30,000 volts or less.

DEFINITIONS

1. **Load radius**—Horizontal distance from the center line of rotation before loading to the center of the vertical loadline or block with load applied.
2. **Load boom angle**—Loaded boom angle is the angle between the first section boom and the horizontal, after lifting the rated load at the rated radius. The boom angle before loading should be greater to account for deflections. The loaded boom angle combined with the boom length give only an approximation of the operating radius.
3. **Working area**—Area measured in a circular arc above the center line of rotation as shown on the Working Area diagram.
4. **Freely suspended load**—Load hanging free with no direct external force applied except by the loadline.
5. **Side load**—Horizontal side force applied to the lifted load either on the ground or in the air.
6. **No load stability limit**—The stability limit radius shown on the range diagrams is the radius beyond which it is not permitted to position the boom plus block configuration because machine can overturn without any load on the hook.
7. **Structural length limit**—An area where the boom or the boom with jib deployed cannot be extended because of structural limitations.
8. **PCSA**—Power Crane and Shovel Association.

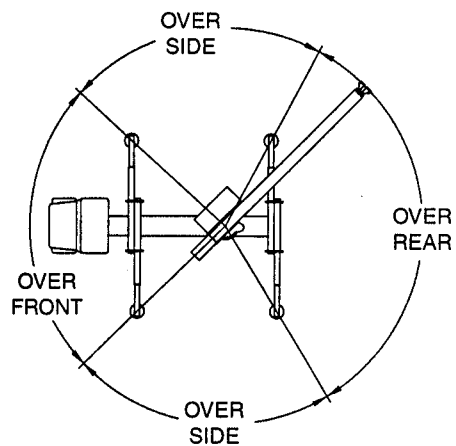

WORK AREA DIAGRAM

INFORMATIONAL DATA

OUTRIGGERS

1. Outrigger spread from center to center of the outrigger floats at mid span is 17' and at full span is 24'6".
2. No outrigger pad load exceeds 55,000 pounds maximum at full span or 65,000 pounds maximum at mid span.

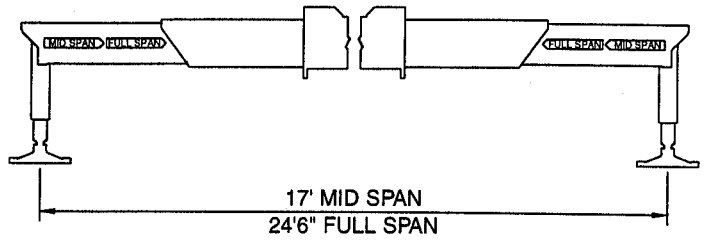

WEIGHT REDUCTIONS FOR LOAD HANDLING DEVICES (See load chart for jib deductions)

1. Hook blocks are rated at maximum capacity for the block. Do not exceed rated cable pull with any block.

	Aux Boom Head	100 lb
	Downhaul Weight	180 lb
5 Ton	1 Sheave Block	375 lb
15 Ton	2 Sheave Block	640 lb
25 Ton	3 Sheave Block	870 lb
35 Ton	4 Sheave Block	970 lb

NOTICE			1 Part Line	2 Part Line	3 Part Line	4 Part Line	5 Part Line	6 Part Line	7 Part Line	8 Part Line
<ul style="list-style-type: none"> • Do not deadhead line block against boom tip when extending boom. • Keep at least 3 wraps of loadline on drum at all times. • Use only 5/8" diameter rotation resistant cable with 45,400 pounds breaking strength on this machine. 										
MAXIMUM BOOM LENGTH AT MAXIMUM ELEVATION WITH RIGGING SHOWN WITH LOAD BLOCK AT GROUND LEVEL			157' Boom & Jib	112'	83'	64'	52'	43'	36'	33'
Winch	Cable Supplied	Average Breaking Strength	Lift and Speed	Lift and Speed	Lift and Speed	Lift and Speed	Lift and Speed	Lift and Speed	Lift and Speed	Lift and Speed
Standard Planetary Winch Low Speed	5/8" diameter rotation resistant 18 x 19 IWRC	45,400 lb	9,000 lb 170 fpm	18,000 lb 85 fpm	27,000 lb 57 fpm	36,000 lb 43 fpm	45,000 lb 34 fpm	54,000 lb 28 fpm	63,000 lb 24 fpm	66,000 lb 21 fpm
Standard Planetary Winch High Speed	5/8" diameter rotation resistant 18 x 19 IWRC	45,400 lb	4,400 lb 340 fpm	8,800 lb 170 fpm	13,200 lb 113 fpm	17,600 lb 85 fpm	22,000 lb 68 fpm	26,400 lb 57 fpm	30,800 lb 49 fpm	35,200 lb 43 fpm

All winch pulls and speeds are shown on the fourth layer. Winch line pulls would increase on the first, second and third layers. Winch line speed would decrease on the first, second and third layers. Winch line pulls may be limited by the winch capacity or the ANSI 5 to 1 cable safety factor. These are shown below:

Winch	Full Drum Pull	Allowable Cable Pull
Standard planetary & Auxiliary planetary	4,400 pounds (high speed) 9,000 pounds (low speed)	9,080 pounds

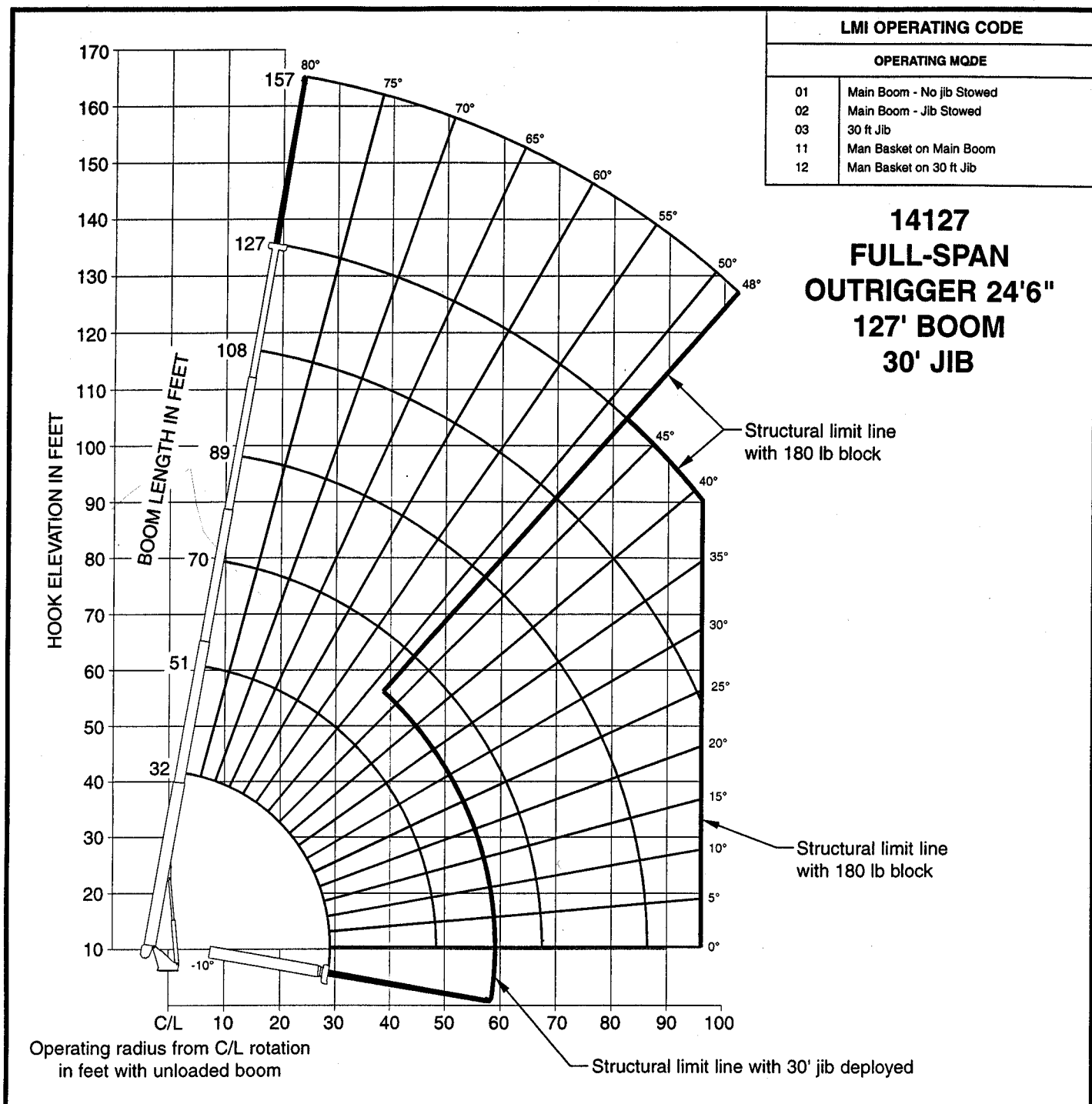
**SET-UP**

1. Fully extend and set outriggers to full-span location, level crane and set front stabilizer.

OPERATION

1. The 32 ft. boom length capacities are based on boom fully retracted. If not fully retracted, do not exceed 51 ft. boom length capacities.
2. Do not extend unloaded boom or jib beyond stability limit line on range chart as loss of stability may occur.
3. Load blocks and slings are considered to be a part of the load.
4. Operate with jib by radius when main boom is fully extended and by boom angle when main boom is partially extended. Do not exceed jib capacities at any partially extended boom length.
5. All jib loads must be lifted with single part reeving.

**14127
127' BOOM
30' JIB**

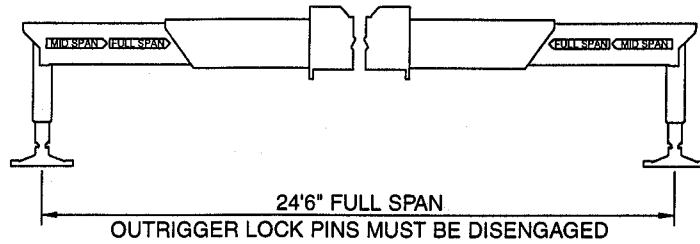

**FULL-SPAN
OUTRIGGER**

32 TO 127 FOOT BOOM RATED LOADS WITHOUT JIB

LOAD RADIUS (ft)	LOADED BOOM ANGLE	32 ft BOOM (lb)	LOADED BOOM ANGLE	A 51 ft BOOM (lb)	LOADED BOOM ANGLE	B 70 ft BOOM (lb)	LOADED BOOM ANGLE	C 89 ft BOOM (lb)	LOADED BOOM ANGLE	D 108 ft BOOM (lb)	LOADED BOOM ANGLE	127 ft BOOM (lb)
6	76.5	66,000										
8	72.3	48,050										
10	68.2	41,250	77.6	33,000								
12	64	36,300	75.6	30,050								
15	57.4	30,700	71.7	26,200	77.5	22,800						
20	45.2	24,550	65.5	20,750	73.3	19,200	77.7	16,800				
25	29.2	19,900	59	17,050	68.9	15,600	74.5	14,400	78	12,400		
30			51.9	14,600	64.3	13,100	71	12,050	75.3	10,700	77.9	8,000
35			44	12,550	59.5	10,900	67.4	9,900	72.7	9,200	75.9	7,700
40			34.6	10,100	54.5	9,400	64.1	8,500	69.9	8,000	73.7	7,300
45			23.4	8,050	49.6	8,250	60.4	7,400	66.9	6,900	71.4	6,500
50					43.7	7,050	56.4	6,350	63.8	5,650	68.8	5,650
55					36.9	5,900	52.3	5,700	60.7	4,950	66.2	4,700
60					28.9	4,800	48	5,100	57.4	4,350	63.3	3,600
65					17.5	3,850	43.1	4,200	54.1	3,900	60.7	3,200
70							37.8	3,400	50.6	3,450	58	2,800
75							31.7	2,700	46.8	2,850	55.2	2,500
80							24.2	2,150	42.8	2,300	52.3	2,200
85							12.8	1,600	38.4	1,800	49.3	1,950
90									33.4	1,350	46	1,500
95									27.7	950	42.4	1,100
100									20.6	600	38.7	750
	0	12,800	0	5,400	0	2,600	0	1,100				

30 FOOT JIB RATED LOADS

LOAD RADIUS (ft)	LOADED BOOM ANGLE	30 ft JIB (lb)
35	78.6	3,850
40	77.1	3,700
45	75.4	3,550
50	73.8	3,400
55	72.1	3,250
60	70.3	3,100
65	68.5	2,950
70	66.5	2,700
75	64.5	2,550
80	62.4	2,300
85	60.2	2,100
90	58	1,850
95	55.6	1,650
100	53.2	1,300
105	50.6	950
110	47.8	650

RATED LOAD REDUCTIONS WITH JIB

BOOM LENGTH	30' JIB STOWED		30' JIB ERECTED	
32'	Reduce load 500 lb		Reduce load 1,250 lb	
51'	Reduce load 350 lb		Reduce load 1,100 lb	
70'	Reduce load 250 lb		Reduce load 1,050 lb	
89'	Reduce load 200 lb		Reduce load 1,000 lb	
108'	Reduce load 150 lb		Reduce load 1,000 lb	
127'	Reduce load 150 lb		Reduce load 950 lb	

Note:

1. All capacities are in pounds, angles in degrees, radius in feet.
2. Loaded boom angles are given as reference only.
3. Shaded areas are structurally limited capacities.
4. Handling of personnel is only permitted with full-span outriggers.

**14127
127' BOOM
30' JIB**

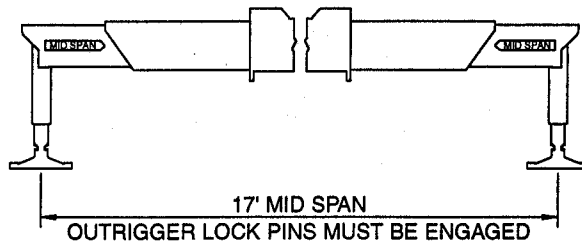

**MID-SPAN
OUTRIGGER**

32 TO 127 FOOT BOOM RATED LOADS WITHOUT JIB

LOAD RADIUS (ft)	LOADED BOOM ANGLE	32 ft BOOM (lb)	LOADED BOOM ANGLE	A 51 ft BOOM (lb)	LOADED BOOM ANGLE	B 70 ft BOOM (lb)	LOADED BOOM ANGLE	C 89 ft BOOM (lb)	LOADED BOOM ANGLE	D 108 ft BOOM (lb)	LOADED BOOM ANGLE	127 ft BOOM (lb)
6	76.5	66,000										
8	72.3	48,050										
10	68.2	41,250	77.6	33,000								
12	64	36,300	75.6	30,050								
15	57.4	30,700	71.7	26,200	77.5	22,800						
20	45	18,700	65.5	20,750	73.3	19,200	77.7	15,800				
25	29	11,200	58.7	12,900	68.7	13,500	74.4	14,100	78	12,400		
30			52.1	8,700	63.9	9,250	70.6	9,700	75.1	10,050	77.9	8,000
35			44.2	6,000	59.4	6,500	67.2	6,950	72.2	7,300	75.9	7,500
40			35	4,200	54.2	4,700	63.4	5,150	69.1	5,350	73.5	5,600
45			22.8	2,800	48.8	3,400	59.5	3,750	66	3,950	70.7	4,200
50					42.8	2,350	55.5	2,700	62.8	2,850	68	3,100
55					36.1	1,550	51.3	1,850	59.6	2,000	65.3	2,200
60					28	850	46.8	1,200	56.3	1,350	62.6	1,450
65							42	650	52.9	750	59.8	900
70											57	500
	0	7,800	0	2,000								

30 FOOT JIB RATED LOADS

LOAD RADIUS (ft)	LOADED BOOM ANGLE	30 ft JIB (lb)
35	78.6	3,850
40	77.1	3,700
45	75.4	3,550
50	73.8	3,400
55	72.1	2,800
60	70	2,100
65	67.8	1,500
70	65.5	1,000
75	63.2	550

RATED LOAD REDUCTIONS WITH JIB

BOOM LENGTH	30' JIB STOWED	30' JIB ERECTED
32'	Reduce load 500 lb	Reduce load 1,250 lb
51'	Reduce load 350 lb	Reduce load 1,100 lb
70'	Reduce load 250 lb	Reduce load 1,050 lb
89'	Reduce load 200 lb	Reduce load 1,000 lb
108'	Reduce load 150 lb	Reduce load 1,000 lb
127'	Reduce load 150 lb	Reduce load 950 lb

Note:

1. All capacities are in pounds, angles in degrees, radius in feet.
2. Loaded boom angles are given as reference only.
3. Shaded areas are structurally limited capacities.
4. Handling of personnel is only permitted with full-span outriggers.

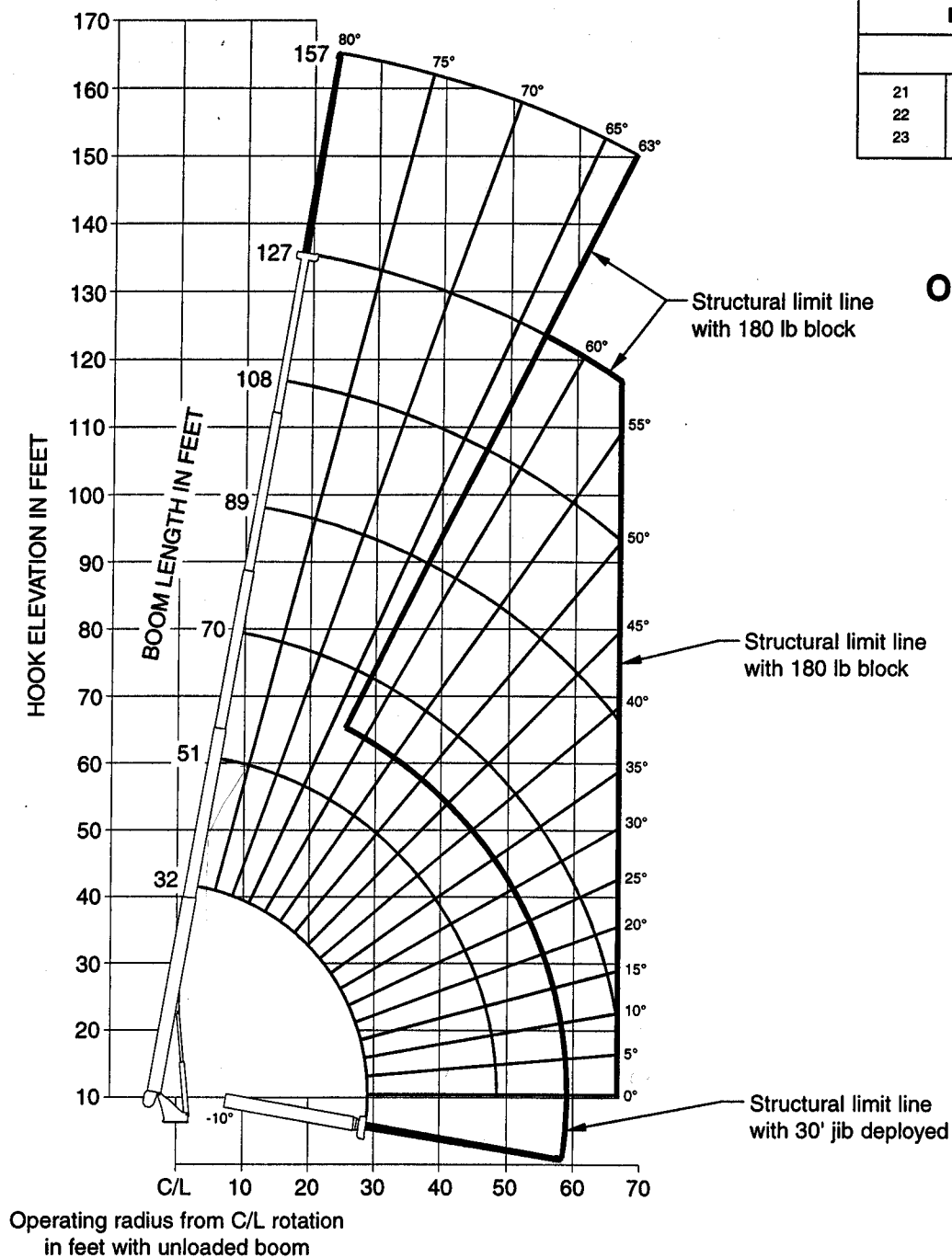
**SET-UP**

1. Engage mid-span outrigger lock pins, extend and set outriggers to mid-span location, level crane and set front stabilizer.

OPERATION

1. The 32 ft. boom length capacities are based on boom fully retracted. If not fully retracted, do not exceed 51 ft. boom length capacities.
2. Do not extend unloaded boom or jib beyond stability limit line on range chart as loss of stability may occur.
3. Load blocks and slings are considered to be a part of the load.
4. Operate with jib by radius when main boom is fully extended and by boom angle when main boom is partially extended. Do not exceed jib capacities at any partially extended boom length.
5. All jib loads must be lifted with single part reeving.