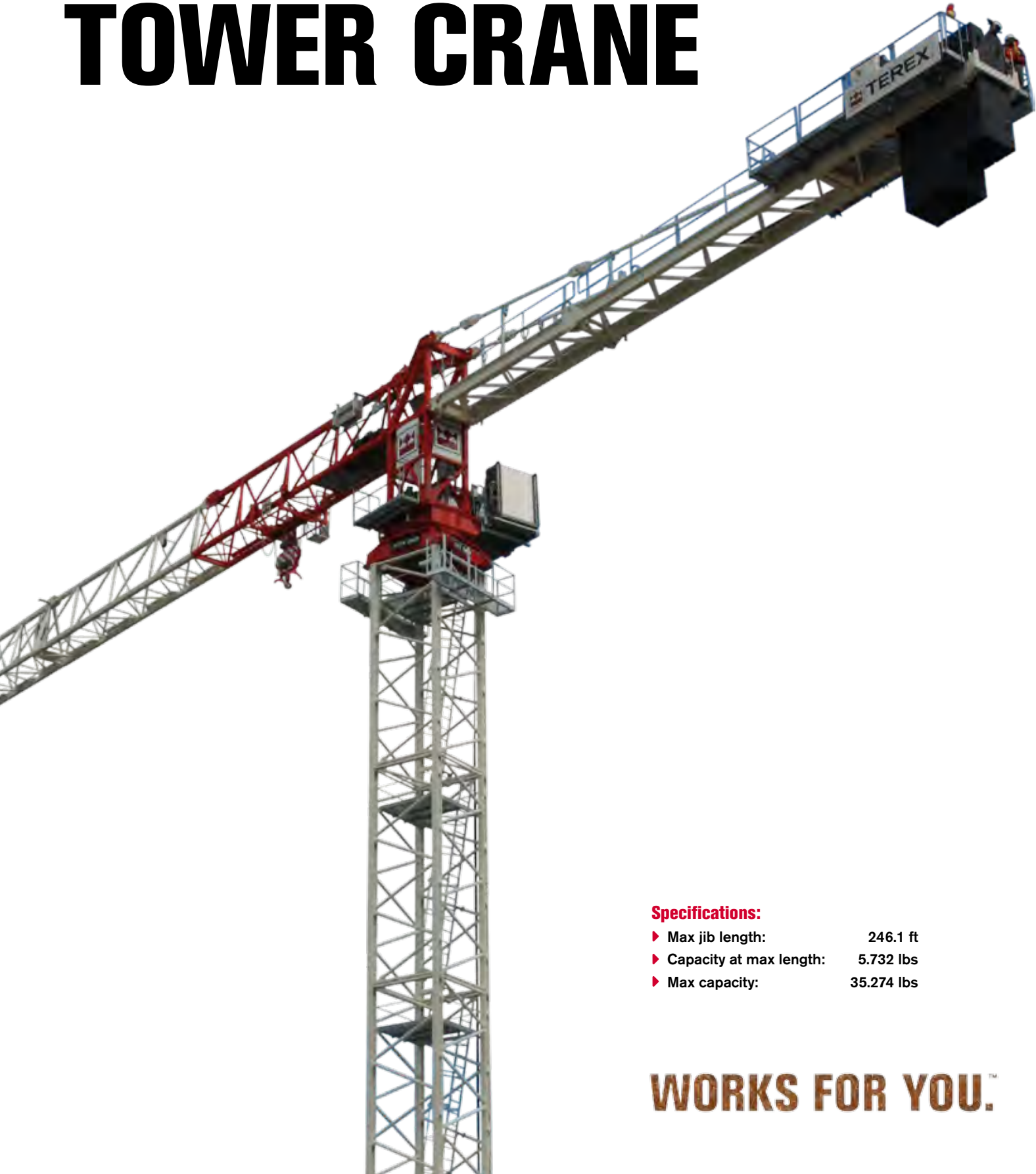

FLAT TOP TOWER CRANE

**Specifications:**

- ▶ Max jib length: 246.1 ft
- ▶ Capacity at max length: 5.732 lbs
- ▶ Max capacity: 35.274 lbs

WORKS FOR YOU.™

KEY

Zeichenerklärung · Légende · Leyenda · Legenda



Hoisting · Heben · Levage · Elevación · Sollevamento



Trolleying · Katzfahren · Distribution · Distribución · Traslazione carrello



Slewing · Schwenken · Orientation · Orientació · Rotazione



Travelling · Schienenfahren · Translation · Traslación · Traslazione



Directive on noise level · Richtlinie für den Schall-Leistungspegel · Directive sur le niveau acoustique · Directiva sobre el nivel acustico · Direttiva sul livello acustico



Consult us · Auf Anfrage · Nous consulter · Consultarnos · Consultateci



Power requirements · Geforderte Stromstärke · Puissance totale nécessaire · Potencia necesaria · Potenza totale richiesta



Power supply · Stromversorgung · Alimentation · Alimentación · Alimentazione



In service · In Betrieb · En service · En servicio · In servizio



Out of service · Außer Betrieb · Hors service · Fuera de servicio · Fuori servizio



Max. under hook height · Höchste Hakenhöhe · Hauteur maxi. sous crochet · Maxima altura bajo gancho · Altezza max. sotto gancho



Without load, without ballast, max. jib and max. height · Ohne Last und Ballast, mit Maximalausleger und Maximalhöhe · A vide, sans lest, avec flèche et hauteur maximum · Sin carga, sin lastre, con pluma y altura máxima · A vuoto, senza zavorra, braccio max., altezza max.



Counterweight · Gegengewicht · Lest de contre-flèche · Lastre de contra flecha · Zavorra controbraccio

C25

FEM 1004 Out of service wind condition · FEM 1004 Windverhältnisse im Außerbetriebszustand · FEM 1004 Conditions de vent hors service · FEM 1004 Condiciones de viento fuera de servicio · FEM 1004 Condizioni del vento in fuori servizio

CONTENTS

CTT 321-16 H20

Inhalt · Contenu · Contenido · Indice



Page · Seite · Page · Pàgina · Pagina:

Load Diagram · Lastkurven · Courbes de charges · Curvas de cargas · Diagramma di portata	4
Tower · Turm · Tour · Torre · Torre	6
Other configurations · Aufstellmöglichkeiten · Autres Implantations Otras Implantaciones · Altre Installazioni	7
Mechanisms · Antriebe · Mécanismes · Mecanismos · Meccanismi	8
Transportation · Transport · Transportation · Transportation · Trasporto	10

LOAD DIAGRAM

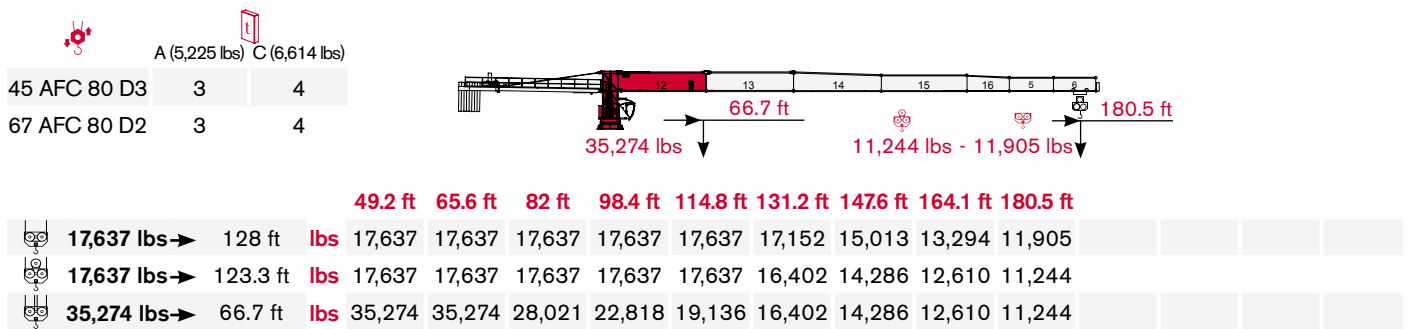
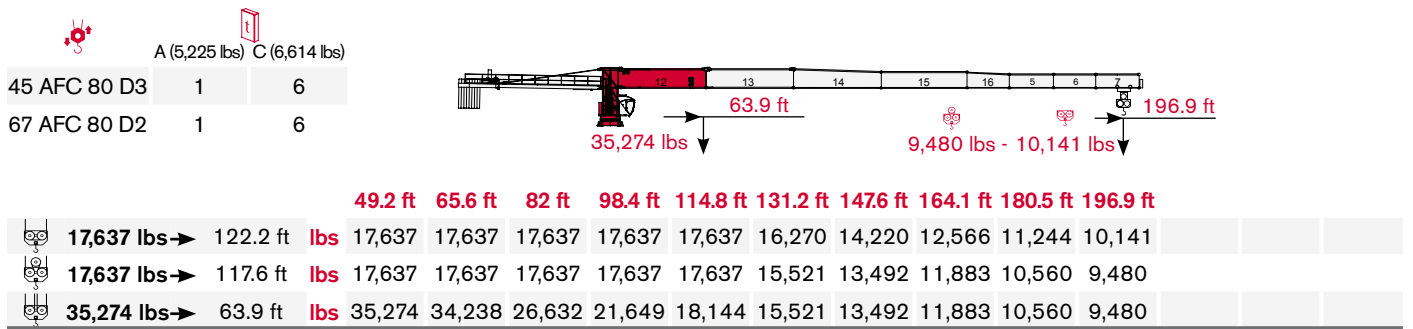
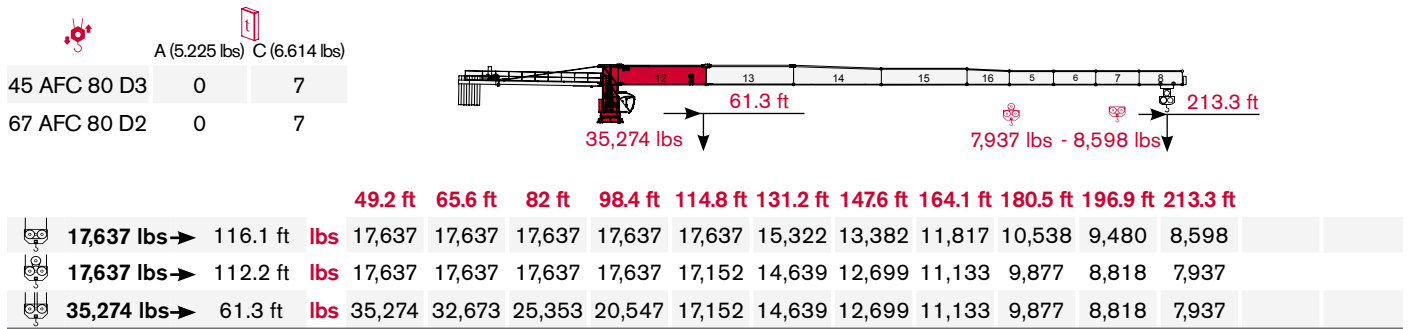
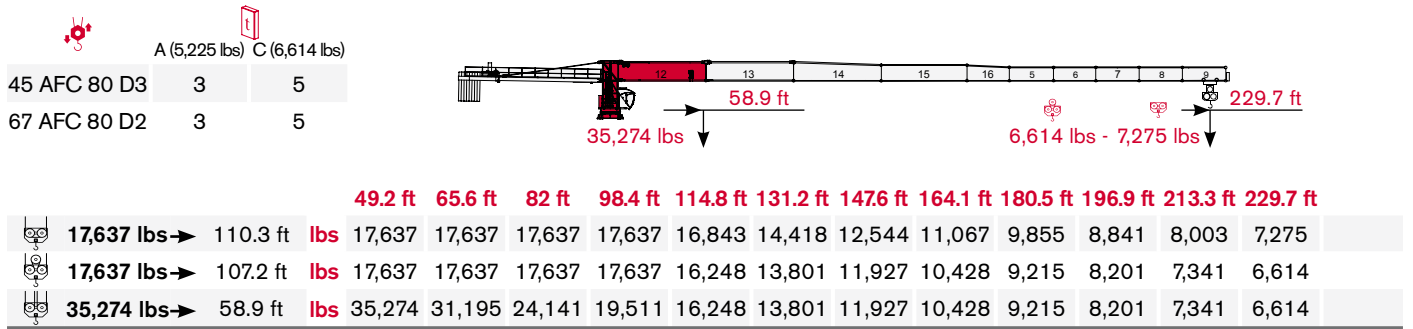
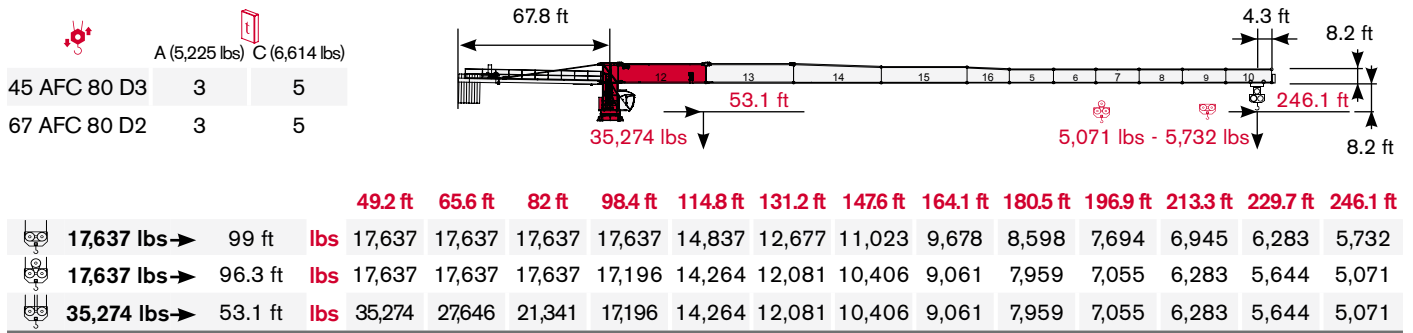
Lastkurven · Courbes de charges · Curvas de cargas · Diagramma di portata



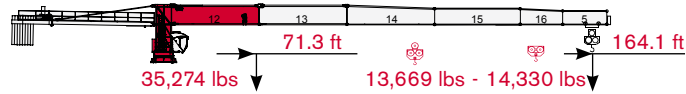

		
	A (5,225 lbs)	C (6,614 lbs)
45 AFC 80 D3	0	6
67 AFC 80 D2	0	6



49.2 ft 65.6 ft 82 ft 98.4 ft 114.8 ft 131.2 ft 147.6 ft 164.1 ft



	17,637 lbs →	136.6 ft	lbs	17,637	17,637	17,637	17,637	17,637	17,637	17,637	16,160	14,330
	17,637 lbs →	131.9 ft	lbs	17,637	17,637	17,637	17,637	17,637	17,637	17,637	15,476	13,669
	35,274 lbs →	71.3 ft	lbs	35,274	35,274	30,159	24,604	20,657	17,725	15,476	13,669	

		
	A (5,225 lbs)	C (6,614 lbs)
45 AFC 80 D3	2	4
67 AFC 80 D2	2	4



49.2 ft 65.6 ft 82 ft 98.4 ft 114.8 ft 131.2 ft 147.6 ft

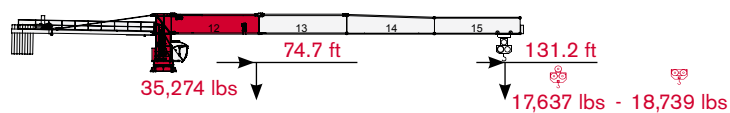

	17,637 lbs →	139.4 ft	lbs	17,637	17,637	17,637	17,637	17,637	17,637	17,637	16,535	
	17,637 lbs →	134.8 ft	lbs	17,637	17,637	17,637	17,637	17,637	17,637	17,637	15,873	
	35,274 lbs →	72.8 ft	lbs	35,274	35,274	30,909	25,199	21,164	18,188	15,873		

		
	A (5,225 lbs)	C (6,614 lbs)
45 AFC 80 D3	0	5
67 AFC 80 D2	0	5



49.2 ft 65.6 ft 82 ft 98.4 ft 114.8 ft 131.2 ft

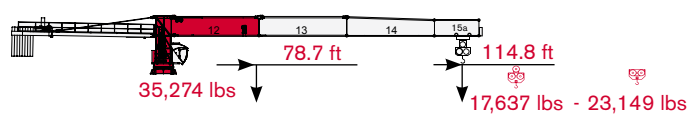

	17,637 lbs →	131.2 ft	lbs	17,637	17,637	17,637	17,637	17,637	17,637	17,637		
	17,637 lbs →	131.2 ft	lbs	17,637	17,637	17,637	17,637	17,637	17,637	17,637		
	35,274 lbs →	74.7 ft	lbs	35,274	35,274	31,791	25,948	21,826	18,739			

		
	A (5,225 lbs)	C (6,614 lbs)
45 AFC 80 D3	2	3
67 AFC 80 D2	2	3



49.2 ft 65.6 ft 82 ft 98.4 ft 114.8 ft

	17,637 lbs →	114.8 ft	lbs	17,637	17,637	17,637	17,637	17,637	17,637			
	17,637 lbs →	114.8 ft	lbs	17,637	17,637	17,637	17,637	17,637	17,637			
	35,274 lbs →	78.7 ft	lbs	35,274	35,274	33,687	27,514	23,149				

		
	A (5,225 lbs)	C (6,614 lbs)
45 AFC 80 D3	0	4
67 AFC 80 D2	0	4

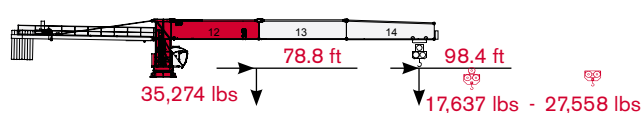

49.2 ft 65.6 ft 82 ft 98.4 ft

	17,637 lbs →	98.4 ft	lbs	17,637	17,637	17,637	17,637					
	17,637 lbs →	98.4 ft	lbs	17,637	17,637	17,637	17,637					
	35,274 lbs →	78.8 ft	lbs	35,274	35,274	33,753	27,558					

TOWER

Turn · Tour · Torre · Torre

Standard Configurations · Standardkonfiguration ·

Standard Implantations · Implantaciones Standard · Installazioni Standard

Tower: H20 & Basement: RTL

	●	◊
R1	-2632 kN	-3147 kN
R2	2020 kN	2631 kN
	931 kN	

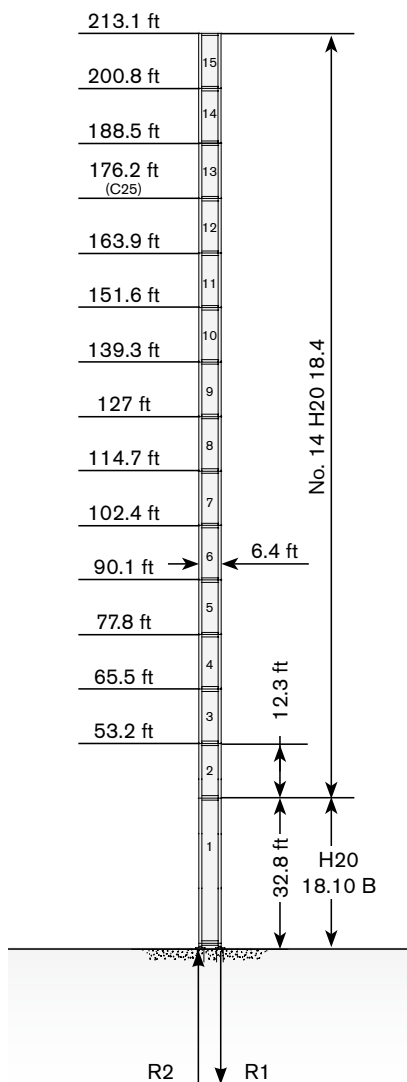

Tower: H20 & Basement: FTR

	●	◊
R1	-1372 kN	-1590 kN
R2	-209 kN	-351 kN
	991 kN	

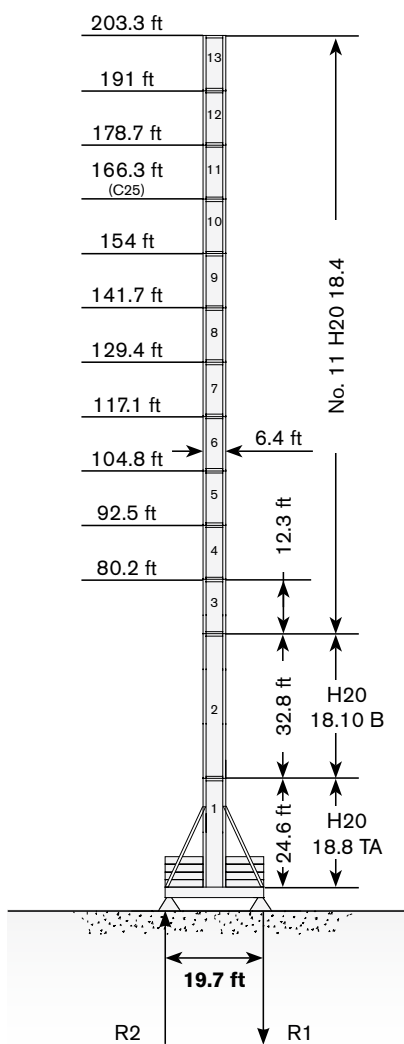

Tower: H20 & Basement: TTR

	●	◊
R1	-1526 kN	-1590 kN
R2	-108 kN	-351 kN
	991 kN	

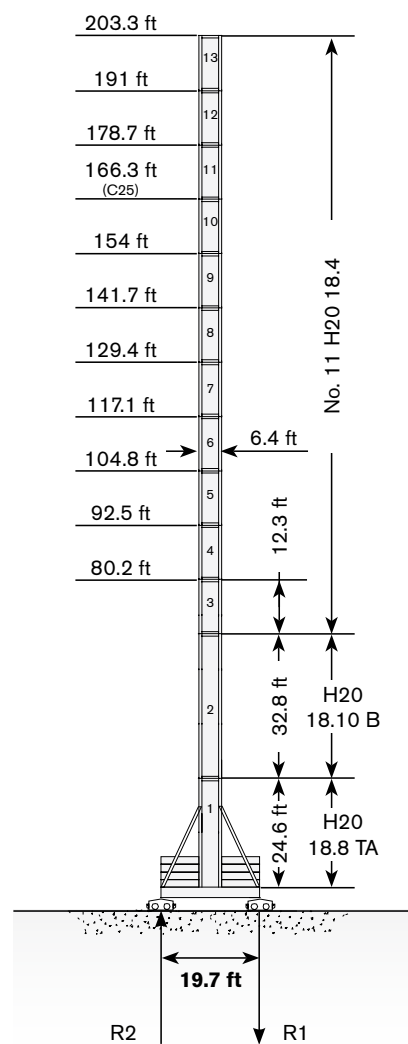

Max. under hook height · Höchste Hakenhöhe · Hauteur maxi. sous crochet · Maxima altura bajo gancho · Altezza max. sotto gancio

Different heights and tower combinations are available; please consult us · Andere Höhen und Turmkombinationen auf Anfrage · Différentes hauteurs et combinaisons de tour sont disponibles; nous consulter · Hay diferentes alturas y combinaciones de torre disponibles. Consúltenos · Altezze diverse e combinazioni di torre sono disponibili; consultateci

Other configurations · Aufstellmöglichkeiten · Autres Implantations · Otras Implantaciones · Altre Installazioni

Bottom climbing crane · Kletterkran im Gebäude · Télescopage sur dalles · Telescopage grúa trepadora · Gru climbing

Crane tied to the structure · Geankerter Kran · Grue ancrée · Grúa anclada · Gru ancorata

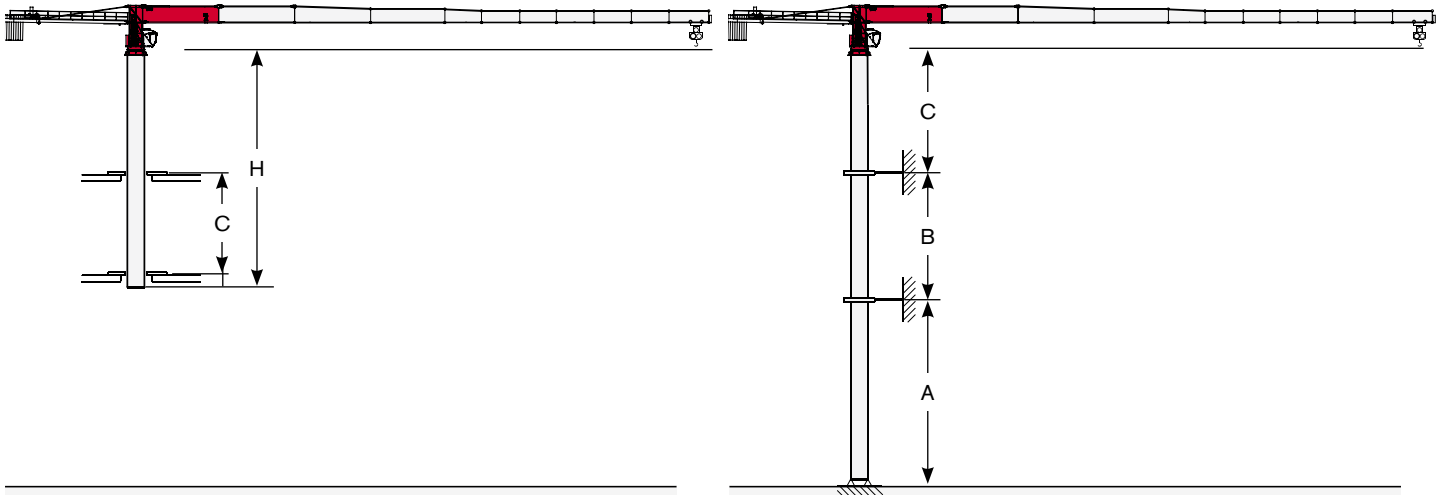

Tower: H20

	min	max
C	32.8 ft	52.5 ft
H	73.8 ft	123 ft

Tower: H20 & Basement: RTL





	min	max
A	108.3 ft	170.6 ft
B	49.2 ft	73.8 ft
C	108.3 ft	

MECHANISMS

Antriebe · Mécanismes · Mecanismos · Meccanismi







Power supply · Stromversorgung ·

Alimentation · Suministro eléctrico · Alimentazione

				
	45 AFC 80	100 kVA*	400V - 50Hz / 460V - 60Hz	2000/14/CE modificata
	67 AFC 80	110 kVA*	400V - 50Hz / 460V - 60Hz	2000/14/CE modificata

* Crane without travelling equipment – Three movements simultaneous at 90% · Krane ohne Schienenfahren – Drei gleichzeitige Bewegungen mit 90% · Grue sans translation – Trois mouvements simultanés à 90% · Grúa sin traslación – Tres movimientos contemporáneos hechos al 90% · Gru senza traslazione – Tre movimenti contemporanei al 90%



Hoisting · Heben · Levage · Elevación · Sollevamento

			lbs	ft/min	kW	
	45 AFC 80 D3 (Vector)		17,637	0 → 95.1	45	2,362.3 ft
			13,228	0 → 121.4		
			8,818	0 → 173.9		
			4,409	0 → 308.4		
			3,748	0 → 360.9		
			35,274	0 → 47.6		
			26,455	0 → 60.7		
			17,637	0 → 86.9		
			8,818	0 → 154.2		
			7,496	0 → 180.5		
	67 AFC 80 D2 (Vector)		17,637	0 → 134.5	67	2,362.3 ft
			13,228	0 → 177.2		
			8,818	0 → 249.4		
			4,409	0 → 433.1		
			4,079	0 → 475.7		
			35,274	0 → 67.3		
			26,455	0 → 88.6		
			17,637	0 → 124.7		
			8,818	0 → 216.5		
			8,157	0 → 237.9		

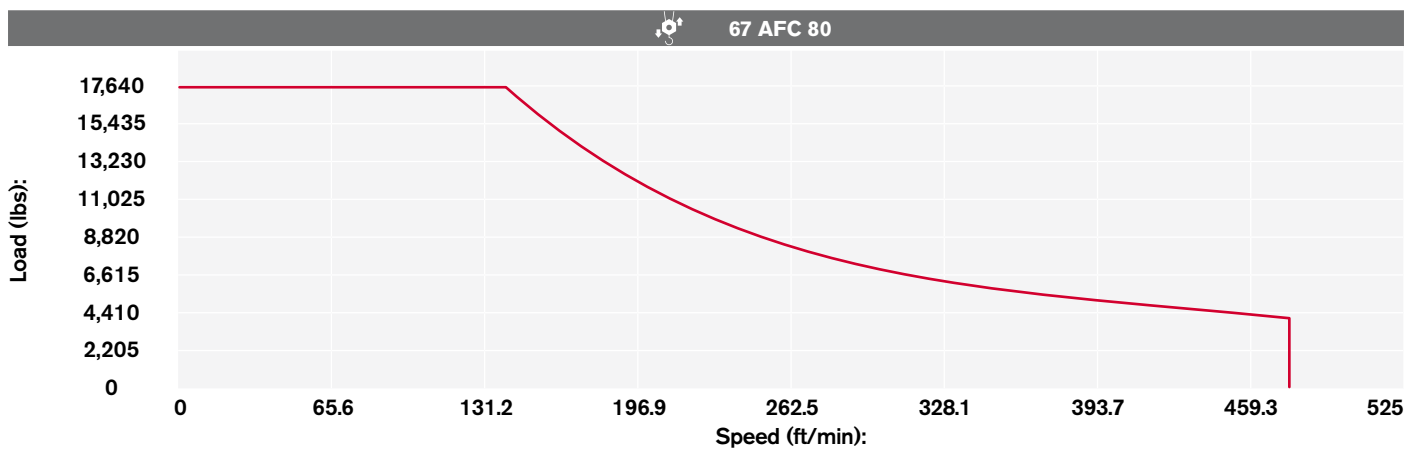
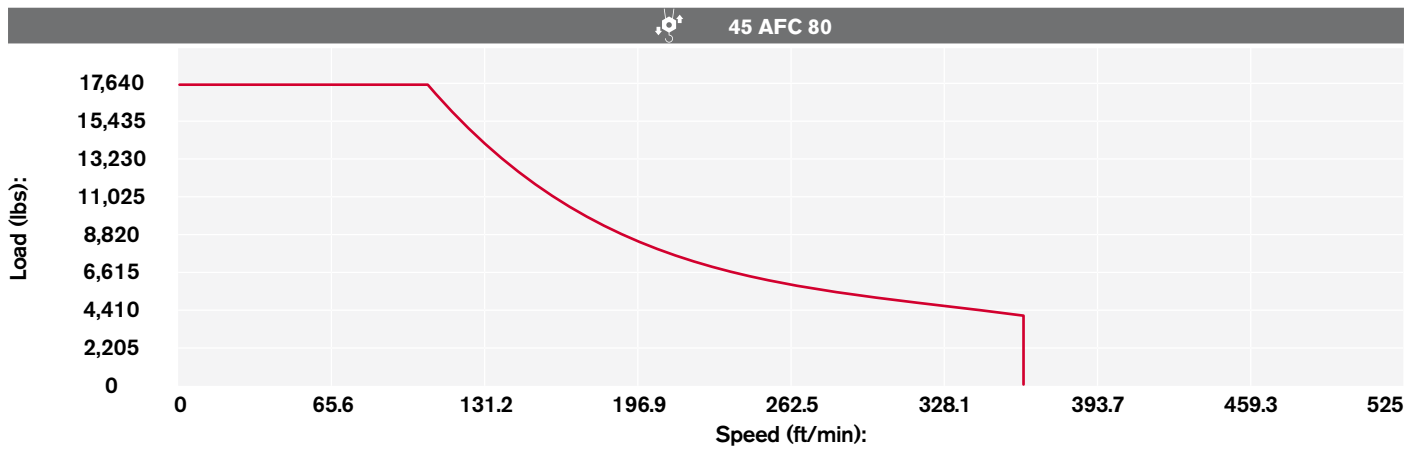
Hoisting Speed · Heben Geschwindigkeit · Vitesse de Levage · Velocidad de Elevación · Velocità' di Sollevamento



Additional Specifications · Weitere Leistungsdaten · Spécifications additionnelles · Otras prestaciones · Altre movimentazioni















	DVF 3 8 D1	41 → 154.2 → 324.8 ft/min	7,5 kW
	SCC 2 2 112 LC	0,75 r.p.m.	2 x 15 kW
	TSR 2RG 4M8	39.4 → 78.7 ft/min (50 Hz) 45.9 → 91.9 ft/min (60 Hz)	4 x 59 ft·lb











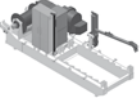

TRANSPORTATION

Transport · Transport · Conducción · Trasporto

Packing list

CTT 321-16 H20	DESCRIPTION · BESCHREIBUNG · DESCRIPTION · DESCRIPCIÓN · DESCRIZIONE	LENGTH · LÄNGE · LONGUEUR · LONGITUD · LUNGHEZZA	WIDTH · BREITE · LARGEUR · ANCHURA · LARGHEZZA	HEIGHT · HÖHE · HAUTEUR · ALTURA · ALTEZZA	QUANTITY · MENGE · QUANTITÉ · CANTIDAD · QUANTITÀ	WEIGHT · GEWICHT · POIDS · PESO · PESO
	6x6 m UNDERCARRIAGE LONG BEAM	29.4 ft	1.6 ft	3.4 ft	1	4,604 lbs
	6x6 m UNDERCARRIAGE SHORT BEAM	14.4 ft	1.6 ft	3.4 ft	2	2,227 lbs
	6x6 m UNDERCARRIAGE JOINING SLEEPER	18 ft	0.5 ft	1.6 ft	2	617 lbs
	6x6 m UNDERCARRIAGE JOINING SLEEPER	18 ft	0.5 ft	1.6 ft	2	485 lbs
	6x6 m UNDERCARRIAGE STRUT	16.7 ft	0.8 ft	1 ft	4	1,103 lbs
	STRUT MOUNTING TOWER ELEMENT HA20 18.8TA FOR 6x6 m UNDERCARRIAGE	24.6 ft	7.5 ft	1 ft	1	14,685 lbs*
	STRUT MOUNTING TOWER ELEMENT HA20 18.8TA FOR 6x6 m UNDERCARRIAGE	24.6 ft	6.4 ft	6.4 ft	1	13,909 lbs*
	HA20 18.10 B TOWER ELEMENT	32.8 ft	6.6 ft	6.4 ft	1	15,435 lbs*
	HA20 18.4 S TOWER ELEMENT	12.3 ft	6.6 ft	6.4 ft	1	6,516 lbs*
	Slewing unit CTT321-16 H20	7.5 ft	7.5 ft	8.2 ft	1	18,103 lbs
	SLEWING UNIT PLATFORM	7.2 ft	2 ft	5.2 ft	1	293 lbs
	CAB EVO 1.5 PLATFORM	14.4 ft	5.9 ft	7.9 ft	1	4,084 lbs
	CAB SECTION CTT 321-16	18 ft	5.6 ft	8.2 ft	1	9,556 lbs
	COUNTERJIB 1B	20 ft	5.2 ft	3 ft	1	5,138 lbs

CTT 321-16 H20

CTT 321-16 H20	DESCRIPTION · BESCHREIBUNG · DESCRIPTION · DESCRIPCIÓN · DESCRIZIONE	LENGTH · LÄNGE · LONGUEUR · LONGITUD · LUNGHEZZA	WIDTH · BREITE · LARGEUR · ANCHURA · LARGHEZZA	HEIGHT · HÖHE · HAUTEUR · ALTURA · ALTEZZA	QUANTITY · MENGE · QUANTITÉ · CANTIDAD · QUANTITÀ	WEIGHT · GEWICHT · POIDS · PESO · PESO
	COUNTERJIB 2B	32.8 ft	5.6 ft	3.3 ft	1	8,114 lbs
	COUNTERJIB 3B	17.4 ft	6.2 ft	7.9 ft	1	45 AFC 80 10,937 lbs 67 AFC 80 11,166 lbs
	COUNTERJIB PLATFORMS UNIT	14.8 ft	2.3 ft	1.3 ft		1,940 lbs
	DERRICK (OPTIONAL)	4.6 ft	1 ft	7.9 ft	1	463 lbs
	JIB SECTION - 12 TT15 24.10	34.8 ft	5.6 ft	8.2 ft	1	10,584 lbs
	JIB SECTION - 13 TT15 15.10	34.8 ft	4.9 ft	7.9 ft	1	7,460 lbs
	JIB SECTION - 14 TT15 15.10	34.5 ft	4.9 ft	7.9 ft	1	5,510 lbs
	JIB SECTION - 15 TT15 15.10	33.8 ft	4.9 ft	6.9 ft	1	4,218 lbs
	JIB SECTION - 16 TT15 15.05	17.4 ft	4.9 ft	6.6 ft	1	1,921 lbs
	JIB SECTION - 05 TT15 15.05	17.4 ft	4.9 ft	5.6 ft	1	1,647 lbs
	JIB SECTION - 06 TT15 15.05	17.1 ft	4.9 ft	5.6 ft	1	1,268 lbs
	JIB SECTION - 07 TT15 15.05	17.1 ft	4.9 ft	5.6 ft	1	988 lbs
	JIB SECTION - 08 TT15 15.05	17.1 ft	4.9 ft	5.6 ft	1	774 lbs
	JIB SECTION - 09 TT15 15.05	16.7 ft	4.9 ft	5.2 ft	1	701 lbs
	JIB SECTION - 10 TT15 15.05	16.7 ft	4.9 ft	5.2 ft	1	600 lbs
	JIB POINT 16t	5.6 ft	3 ft	5.2 ft	1	375 lbs
	TROLLEY 16t	7.2 ft	5.9 ft	3.9 ft	1	1,080 lbs
	HOIST WINCH UNIT FOR 30 TO 55 M JIB	3.9 ft	1.6 ft	6.6 ft	1	1,103 lbs

* including, ladders, platforms, assembly, equipment and strut mounting brackets

www.terexcranes.com

Effective Date: June 2010.

Product specifications and prices are subject to change without notice or obligation. The photographs and/or drawings in this document are for illustrative purposes only. Refer to the appropriate Operator's Manual for instructions on the proper use of this equipment. Failure to follow the appropriate Operator's Manual when using our equipment or to otherwise act irresponsibly may result in serious injury or death. The only warranty applicable to our equipment is the standard written warranty applicable to the particular product and sale and Terex makes no other warranty, express or implied. Products and services listed may be trademarks, service marks or trade-names of Terex Corporation and/or its subsidiaries in the USA and other countries. All rights are reserved. Terex® is a registered trademark of Terex Corporation in the USA and many other countries.

Gültig ab: Juni 2010.

Produktbeschreibungen und Preise können jederzeit und ohne Verpflichtung zur Ankündigung geändert werden. Die in diesem Dokument enthaltenen Fotos und/oder Zeichnungen dienen rein anschaulichen Zwecken. Anweisungen zur ordnungsgemäßen Verwendung dieser Ausrüstung entnehmen Sie bitte dem zugehörigen Betriebshandbuch. Nichtbefolgung des Betriebshandbuchs bei der Verwendung unserer Produkte oder anderweitig fahrlässiges Verhalten kann zu schwerwiegenden Verletzungen oder Tod führen. Für dieses Produkt wird ausschließlich die entsprechende, schriftlich niedergelegte Standardgarantie gewährt. Terex leistet keinerlei darüber hinaus gehende Garantie, weder ausdrücklich noch stillschweigend. Die Bezeichnungen der aufgeführten Produkte und Leistungen sind gegebenenfalls Marken, Servicemarken oder Handelsnamen der Terex Corporation und/oder ihrer Tochtergesellschaften in den USA und anderen Ländern. Alle Rechte vorbehalten. „TEREX“ ist eine eingetragene Marke der Terex Corporation in den USA und vielen anderen Ländern.

Date d'effet : Juin 2010.

Les spécifications et prix des produits sont sujets à modification sans avis ou obligation. Les photographies et/ou dessins contenus dans ce document sont uniquement pour illustration. Veuillez vous référer à la notice d'utilisation appropriée pour les instructions quant à l'utilisation correcte de cet équipement. Tout manquement au suivi de la notice d'utilisation appropriée lors de l'utilisation de notre équipement ou tout acte autrement irresponsable peut résulter en blessure corporelle sérieuse ou mortelle. La seule garantie applicable à notre équipement est la garantie standard écrite applicable à un produit et à une vente spécifique. Terex n'offre aucune autre garantie, expresse ou implicite. Les produits et services proposés peuvent être des marques de fabrique, des marques de service ou des appellations commerciales de Terex Corporation et/ou ses filiales aux Etats Unis et dans les autres pays, et tous les droits sont réservés. «TEREX» est une marque déposée de Terex Corporation aux Etats Unis et dans de nombreux autres pays.

Fecha efectiva: Junio 2010.

Los precios y las especificaciones de productos pueden sufrir cambios sin aviso previo u obligación. Las fotografías o dibujos de este documento tienen un fin meramente ilustrativo. Consulte el manual de instrucciones del operador correspondiente para más información sobre el uso correcto de este equipo. El hecho de no respetar el manual del operador correspondiente al utilizar el equipo o actuar de forma irresponsable puede suponer lesiones graves o fatales. La única garantía aplicable a nuestro equipo es la garantía escrita estándar correspondiente a cada producto y venta, y TEREX no amplía dicha garantía de forma expresa o implícita. Los productos y servicios mencionados pueden ser marcas registradas, marcas de servicio o nombres de marca de TEREX Corporation o de sus filiales en Estados Unidos de América y otros países, y se reservan todos los derechos. „TEREX“ es una marca comercial registrada de Terex Corporation en Estados Unidos de América y muchos otros países.

Data di inizio validità: Giugno 2010.

Ci riserviamo il diritto di modificare le specifiche e i prezzi dei prodotti in ogni momento e senza preavviso. Le fotografie e/o i disegni contenuti in questo documento sono destinati unicamente a scopi illustrativi. Consultare le istruzioni sull'uso corretto di questo macchinario, contenute nell'opportuno Manuale dell'operatore. L'inottemperanza delle istruzioni contenute nel Manuale dell'operatore del macchinario e altri comportamenti irresponsabili possono provocare gravi lesioni, anche mortali. L'unica garanzia applicabile ai nostri macchinari è la garanzia scritta standard applicabile al particolare prodotto e alla particolare vendita; Terex è esonerata dal fornire qualsiasi altra garanzia, esplicita o implicita. I prodotti e servizi elencati possono essere dei marchi di fabbrica, marchi di servizio o nomi commerciali di TEREX Corporation e/o società affiliate negli Stati Uniti d'America e altre nazioni e tutti i diritti sono riservati. „TEREX“ è un marchio registrato di Terex Corporation negli USA e molti altri Paesi.

Copyright 2010 Terex Corporation

Terex Cranes, Global Marketing, Dinglerstraße 24, 66482 Zweibrücken, Germany
Tel. +49 (0) 6332 830, Email: info.cranes@terex.com, www.terexcranes.com

Brochure Reference: TC-DS-IMP-E/F/G/I/S-CTT321-16 H20-11/10



WORKS FOR YOU.™