

PEINER SN 406

FEM 1001/3 USA	A3
Lifting capacity Max. Tragfähigkeit	44 000 lbs 20.0 t

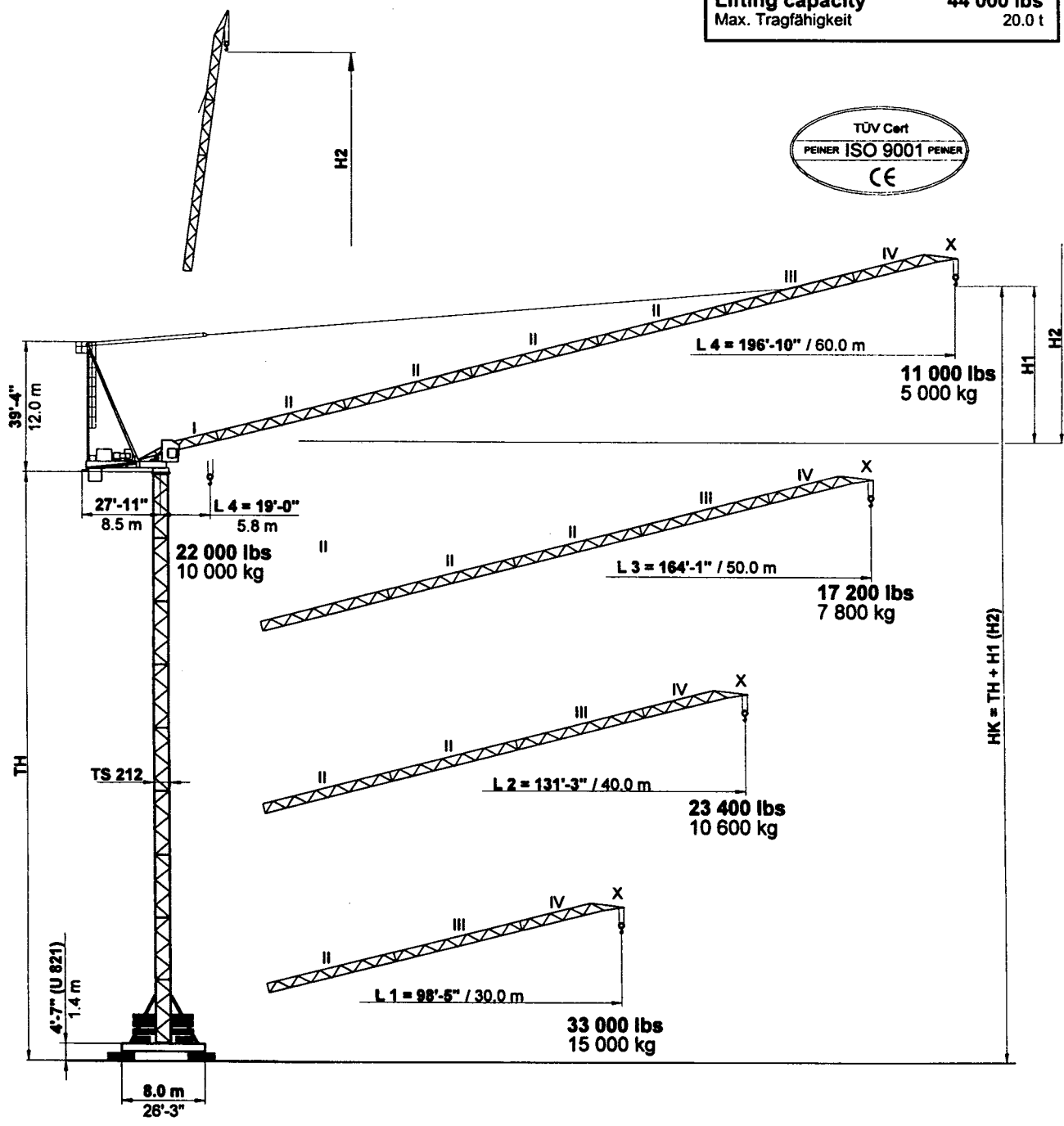

SN 406 Combinations of tower section, hook heights, forces acting per corner, base ballast
 Turmkombinationen, Hakenhöhen, Eckkräfte, Zentralballast

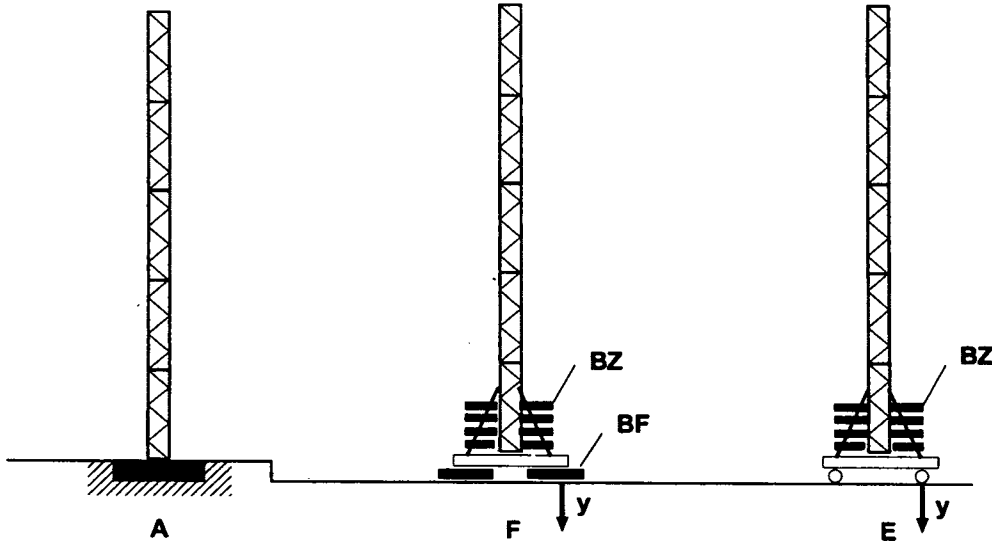

Version:

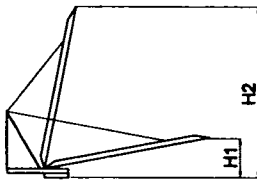

Hook height HK = Tower height TH + H1 (= TH + H2) Hakenhöhe HK = Turmhöhe TH + H1 (= TH + H2)				
	L 1	L 2	L 3	L 4
H1	20'-0" 6.1 m	29'-10" 9.1 m	39'-8" 12.1 m	49'-6" 15.1 m
H2	82'-4" 25.1 m	118'-1" 36.0 m	150'-7" 45.9 m	183'-1" 55.8 m

U 821

UF 821

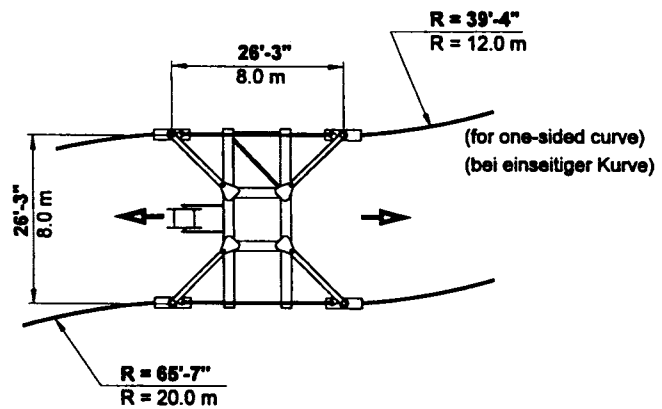
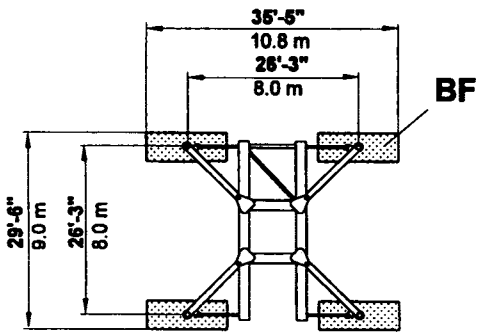

Ground support
Bodenauflagen

Version:

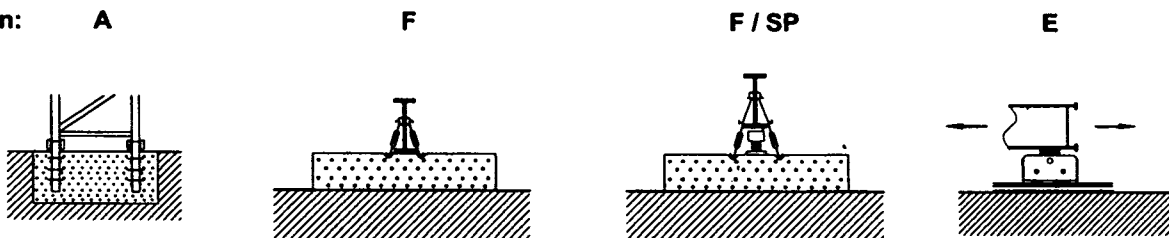

SN 406 Turm / Tower / Tour TS 212

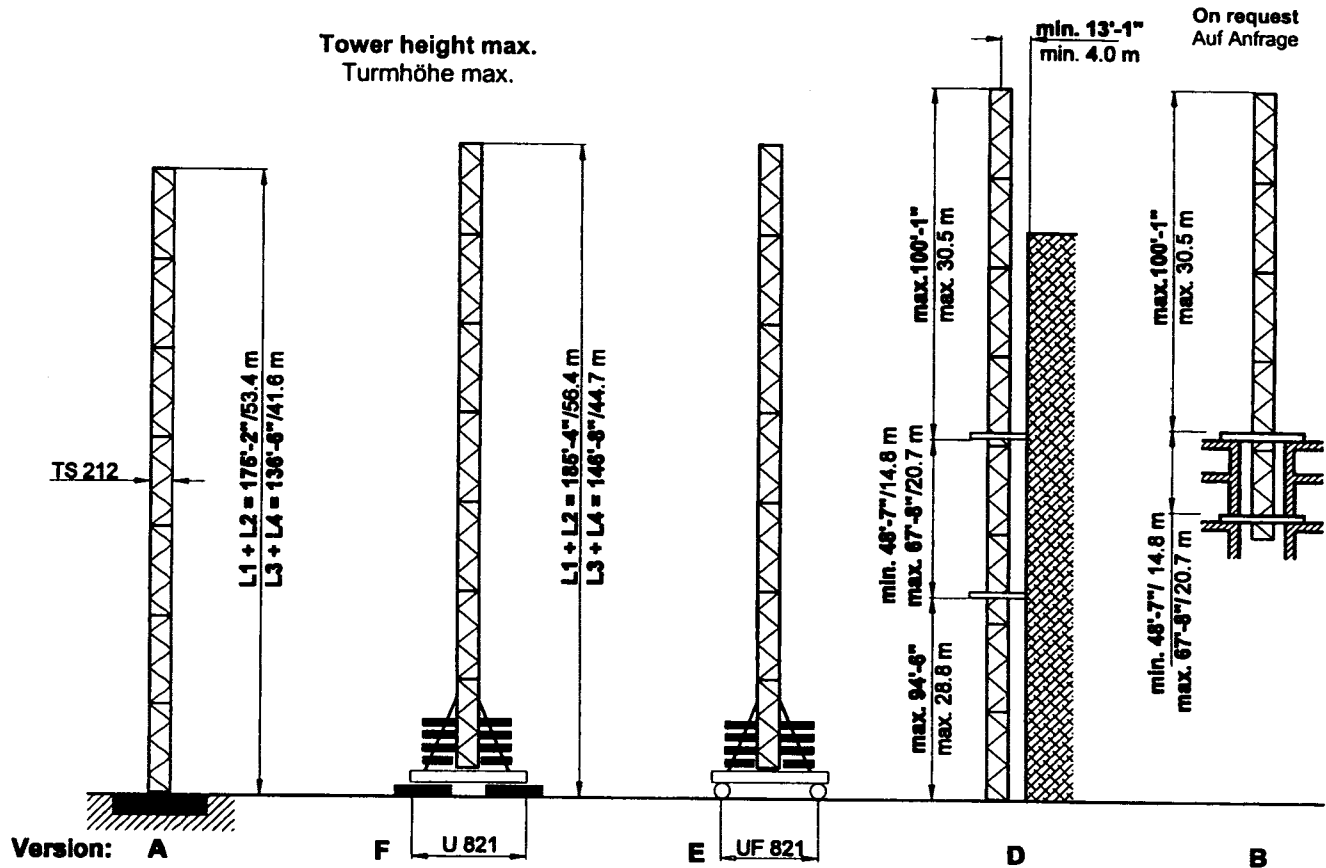



TS 212	Version A	Version F						Version E					
		Tower		Tower		BZ + BF	y	L1 + L2			L3 + L4		
Turm	TH	Turm	TH	kips	t			kips	t	kips	t	kips	t
TS 212.1	ft m	TSV 212 TS 212.1	ft m	kips	t	kips	t	kips	t	kips	t	kips	t
9 x TS 212.1	175'-2" * 53.4 *	1 x TSV 212 8 x TS 212.1	185'-4" 56.5					203 92.4	244 1084	259 1150			
8 x TS 212.1	156'-10" * 47.5 *	1 x TSV 212 7 x TS 212.1	166'-0" 50.6					203 92.4	248 1101	254 1129			
7 x TS 212.1	136'-6" 41.6	1 x TSV 212 6 x TS 212.1	147'-8" 44.7					174 79.2	231 1028	222 986	203 92.4	220 979	271 1206
6 x TS 212.1	117'-2" 35.7	1 x TSV 212 5 x TS 212.1	127'-4" 38.8	On request Auf Anfrage				145 66.0	215 956	191 848	203 92.4	223 992	254 1128
5 x TS 212.1	98'-9" 29.8	1 x TSV 212 4 x TS 212.1	108'-11" 32.9					116 52.8	195 867	166 740	145 66.0	200 891	214 953
4 x TS 212.1	78'-5" 23.9	1 x TSV 212 3 x TS 212.1	89'-7" 27.0					87 396	184 819	153 679	116 52.8	185 825	184 819
3 x TS 212.1	59'-1" 18.0	1 x TSV 212 2 x TS 212.1	69'-3" 21.1					87 39.6	176 785	145 649	87 39.6	170 760	153 679
2 x TS 212.1	40'-8" 12.1	1 x TSV 212 1 x TS 212.1	50'-10" 15.2					87 39.6	163 724	134 596	87 39.6	157 700	136 605
1 x TS 212.1	20'-4" 6.2	1 x TSV 212	31'-6" 9.3					87 39.6	157 699	129 575	87 39.6	151 674	130 580
Foundation Fundament 25'-3" x 25'-3" x 3'-9" 7.7 x 7.7 x 1.7 m		Stationary base Unterwagen U 821				Travelling base Unterwagen, kurvenfahrbar UF 821							
Anchor stools Fundamentfüße 4 x FF 212				BF 4 x 8.82 kips 4 x 4.0 t	BZ block 14.55 kips Block 6.6 t	Bogie / curve Fahrschemel / Kurve F 500							

* only for L1 and L2; nur bei L1 und L2



















TS 212.1 = 5.9 m / 19'-4 1/4"

TSV 212 = 7.9 m / 25'-11"

SN 406 Radius and capacity / Ausladung und Tragfähigkeit

Boom Ausleger	ft m	max. capacity max. Tragfähigkeit	Radius [ft] and capacity [kips] Ausladung [m] und Tragfähigkeit [t]															
			65.6 20.0	75.5 23.0	82.0 25.0	98.4 30.0	103.0 31.4	114.8 35.0	129.8 39.5	131.2 40.0	139.4 42.5	147.6 45.0	155.8 47.5	164.0 50.0	172.2 52.5	180.4 55.0	188.6 57.5	196.9 60.0
			 44.0 kips 20.0t															
L4	196.8 60.0																	
L3	164.0 50.0																	
L2	131.2 40.0	10.5 – 72.2 3.2 - 22.0	44.0 20.0	42.1 19.1	38.6 17.5	31.7 14.4	30.2 13.7	26.9 12.2	23.6 10.7	23.4 10.6								
L1	98.4 30.0	6.6 – 75.5 2.0 - 23.0	44.0 20.0	44.0 20.0	40.1 18.2	33.9 15.0												
			 22.0 kips 10.0t															
L4	196.8 60.0	19.0 – 103.0 5.8 – 31.4	22.0 10.0	22.0 10.0	22.0 10.0	22.0 10.0	22.0 10.0	19.6 8.9	17.2 7.8	17.0 7.7	16.9 7.2	15.0 6.8	14.1 6.4	13.4 6.1	12.8 5.8	12.1 5.5	11.5 5.2	11.0 5.0
L3	164.0 50.0	17.8 – 129.6 4.5 – 39.5	22.0 10.0	22.0 10.0	22.0 10.0	22.0 10.0	22.0 10.0	22.0 10.0	22.0 10.0	21.8 9.9	20.6 9.3	19.2 8.7	18.1 8.2	17.2 7.8				
L2	131.2 40.0	10.5 – 131.2 3.2 – 40.0	22.0 10.0	22.0 10.0	22.0 10.0	22.0 10.0	22.0 10.0	22.0 10.0	22.0 10.0	22.0 10.0								
L1	98.4 30.0	6.6 – 98.4 2.0 – 30.0	22.0 10.0	22.0 10.0	22.0 10.0	22.0 10.0												

Speeds / Geschwindigkeiten

SR WB 66-125/4		t = 3.1 min																108 HP 79 kW	
SR 10-190/3		v = 0 → 96 fpm (30 m)																2 x 16 HP 2 x 12 kW	
SR WB 150/4		v = 0 → 1.02 rpm (min ⁻¹)																L 1, L 2 1 x 12 HP 1 x 9 kW	
																			L 3, L 4 2 x 12 HP 2 x 9 kW
 HK max. = 820 ft / 250 m																6 - layers / 6 - Lagen		480 V / 60 Hz / 3 ph	
Type SR WB 66-100/4F [108 HP] [79 kW]				450 fpm 134 m / min	5 500 lbs 2 500 kg			290 fpm 85 m / min	9 200 lbs 4 200 kg			180 fpm 54 m / min	15 600 lbs 7 100 kg			225 fpm 67 m / min	11 000 lbs 5 000 kg	Total motor output 240 HP Motorenleistung ges. 180 kW without / ohne SR 10-190/3	
				115 fpm 34 m / min	22 000 lbs 10 000 kg			145 fpm 43 m / min	8 400 kg										
								90 fpm 27 m / min	31 300 lbs 14 200 kg										
								58 fpm 17 m / min	44 000 lbs 20 000 kg										
																		Connected power Anschlußleistung	340 kVA

Counterweight / Gegengewichtsballast

Boom / Ausleger			L 1	L 2	L 3	L 4
Counterweight Gegengewicht	BG	[kips]	66.0	66.0	70.4	70.4
		[t]	30.0	30.0	32.0	32.0
		[kips]	6 x 11.0	6 x 11.0	2 x 2.2 6 x 11.0	2 x 2.2 6 x 11.0
		[t]	6 x 5.0	6 x 5.0	2 x 1.0 6 x 5.0	2 x 1.0 6 x 5.0

SN 356/406 Dimensions and weights of transport

Transportmaße und Transportgewichte

Mounting weights see operating manual!
Montagegewichte siehe Betriebsanleitung!

	Designation Benennung			Dimensions [ft] Abmessungen [m]			Weight Gewicht kips / t	Volume Volumen ft ³ / m ³		
				l	b	h				
1	Boom section I Auslegerschuss I			19.8	7.4	5.9	3.6	864		
				6.03	2.25	1.79	1.64	24.3		
2	Boom section II Auslegerschuss II			34.51	7.28	5.77	3,4	1449		
	Section L1 - L2 Schuss L1 - L2			10.52	2.22	1.76	1,54	41,1		
	Section L2 - L3 Schuss L2 - L3			34.51	7.28	5.77	3,1	1449		
	Section L3 - L4 Schuss L3 - L4			10.52	2.22	1.76	1,39	41,1		
	Boom section III Auslegerschuss III			34.51	7.28	5.77	2,9	1449		
				10.52	2.22	1.76	1,32	41,1		
				34.91	7.28	6.07	3,0	1449		
				10.64	2.22	1.85	1,35	41,1		
3	Boom section IV Auslegerschuss IV			22.15	5.61	6.89	2,6	856		
				6.75	1.71	2.10	1,19	24,2		
4	Turntable with DA and slewing gear Drehbühne mit DA und Drehwerk			13.19	8.33	7.71	29,5	847		
				4.02	2.54	2.35	13,4	24,0		
5	Counter jib Gegenausleger			19.75	7.28	4.99	15,1	717		
				6.02	2.22	1.52	6,88	20,3		
6	Cab with support, railing, electrical panel Kabine mit Podest, Geländer, Schaltschrank			20.73	6.23	7.55	6,1	975		
				6.32	1.90	2.30	2,78	27,6		
7	A-frame with ladder Bockspitze mit Leiter			38.39	6.86	3.22	9,8	848		
				11.70	2.09	0.98	4,47	24,0		
8	Hoist winch with rope Hubwinde mit Seil			6.23	8.23	3.97	9,0	204		
		66 WB		1.90	2.51	1.21	4,10	5,8		
9	Luffing winch with rope Verstellwinde mit Seil			9.68	6.92	3.97	7,6	266		
		66 WB		2.95	2.11	1.21	3,43	7,5		
10	Counterweight ballast Gegengewichtsballast			5.58	0.46	7.48	2,2	19		
		BG		1.70	0.14	2.28	1,00	0,5		
				5.58	1.44	10,10	11,0	81		
				1.70	0.44	3,08	5,00	2,3		
11	Counterweight carriage Ballastwagen			18.11	2.95	4.36	2,9	233		
				5.52	0.90	1.33	1,34	6,6		
12	Tower section Turmschuss with struts mit Streben			TS 212.1		19.52	7.78	8,01	9,13	1216
				TSV 212		5.95	2.37	2,45	4,14	34,4
						31.17	9,84	10,00	20,33	3067
				9.50	3,00	3,05	9,22	86,9		
13	Travelling base, folded Unterwagen, kurvenfahrb., geklappt			41.01	9.74	7,05	35,05	2816		
		UF 821		12.50	2.97	2,15	15,90	79,8		
14	Stationary base Unterwagen, stationär			34.55	9.06	2,79	17,13	873		
		U 821		10.53	2.76	0,85	7,77	24,7		
15	Central ballast block Zentralballaststein			14.77	6.73	1,31	14,55	130		
		BZ		4.50	2.05	0,40	6,60	3,7		
16	Foundation pad Fundamentblock			9.84	3.94	2,46	13,22	95		
		BF		3.00	1.20	0,75	6,00	2,7		
17	Accessories Diverse Montageteile									



TEREX PEINER GmbH • Gottbillstr. 1-7 • D-54294 Trier, Germany
Tel. (++49) 6 51 / 8 10 08-0 • Fax (++49) 6 51 / 8 93 00 u. 8 76 40

internet: <http://www.peiner.com>
e-mail: terex@peiner.com