

TRUCK CRANE

TG-3600M

JAPANESE SPECIFICATIONS

TG

CARRIER MODEL	SPEC. NO.
NISSAN DIESEL KC-KL630YN	TG-3600M-2

The "fully automatic luffing jib" and the "luffing jib" are optional equipment.
Refer to the specifications in the following pages regarding the details of these optional jibs.

Control No. TG-3600M-2/MB-90

TG-3600M

CRANE SPECIFICATIONS

CRANE CAPACITY

Boom				
14.2m	Boom	360,000kg	at 3.0m	(17part-line x2)
17.3m, 20.3m, 22.6m, 23.4m	Boom	180,000kg	at 6.0m	(17part-line)
31.0m	Boom	130,000kg	at 7.0m	(12part-line)
32.6m	Boom	130,000kg	at 6.0m	(12part-line)
39.4m	Boom	100,000kg	at 8.0m	(9part-line)
41.8m	Boom	100,000kg	at 7.0m	(9part-line)
47.8m	Boom	70,000kg	at 9.0m	(6part-line)
51.0m	Boom	70,000kg	at 7.0m	(6part-line)
Single top		12,500kg		(1part-line)
[Reference]				
Fully automatic luffing jib				
11.1m	Jib	54,000kg	at 10.0m	(5part-line)
19.1m	Jib	29,000kg	at 8.0m	(3part-line)
27.1m	Jib	10,000kg	at 22.0m	(1part-line)
35.1m	Jib	9,500kg	at 16.0m	(1part-line)
Luffing jib				
17m	Jib	100,000kg	at 10.0m	(9part-line)
23m	Jib	80,000kg	at 12.0m	(8part-line)
35m	Jib	51,600kg	at 16.0m	(6part-line)
47m	Jib	31,000kg	at 18.0m	(4part-line)
*65m	Jib	8,000kg	at 35.0m	(1part-line)
*70m	Jib	5,000kg	at 55.0m	(1part-line)

For the mark *, luffing jib (47m) + extension jib

MAX.LIFTING HEIGHT

Boom	51.0m (70.0t)
[Reference]	Fully automatic luffing jib 88.0m (8.0t)
[Reference]	Luffing jib
	98.0m (9.5t)
	119.0m (3.5t) (luffing jib + extension jib)

MAX.WORKING RADIUS

Boom	46.0m (12.1t)
[Reference]	Fully automatic luffing jib 70.0m (1.5t)
[Reference]	Luffing jib
	70.0m (3.9t)
	90.0m (3.2t) (luffing jib + extension jib)

BOOM LENGTH

14.2m – 51.0m

MAIN WINCH SINGLE LINE SPEED

145m/min (5th layer)

AUXILIARY WINCH SINGLE LINE SPEED

145m/min (5th layer)

BOOM ELEVATION ANGLE

-1° ~ 83°

BOOM ELEVATION SPEED

-1° ~ 83° 140s

SWING ANGLE

360° continue

SWING SPEED

1.1rpm

WIRE ROPE

Main Winch
25mm x 450m (Diameter x Length)
Non spin type

Auxiliary Winch
25mm x 450m (Diameter x Length)
Non spin type

HOOK

180t hook (17part-line)
80t hook (6part-line)
25t hook (2part-line) . . . option
12.5t hook (1part-line)

BOOM

5-section hydraulically sequentially telescoping boom of box construction
Every step lock or no lock
(spring type and air cylinder type)

BOOM EXTENSION

4 double-acting hydraulic cylinders

SINGLE TOP

Single sheave. Mounted to main boom head by pin.

HOIST

Driven by hydraulic variable motor and via planetary gear reducer.

Automatic brake

High/low speed changeover and creep operation device provided.

2 single winches

BOOM ELEVATION

2 double-acting hydraulic cylinders

SWING

Hydraulic motor driven planetary gear reducer

Roller type swing bearing

Disk type negative brake

High/low speed changeover and creep operation device provided.

Swing free/lock changeover type

Pneumatically operated swing lock

OUTRIGGERS

Fully hydraulic H-type 3 steps

Slides and jacks each provided with independent operation device.

Fully extended width 8.8m

Middle extended width 7.0m, 5.9m

Extended width detector provided.

FRONT JACK

1 hydraulic type (with grounding detector)

REAR JACK

2 hydraulic types (with grounding detector)

ENGINE FOR CRANE

Engine exclusive to upper component operation

Model NISSAN DIESEL RF804

Type 4-cycle, V8-cylinder, direct-injection, water-cooled diesel engine

Piston displacement 16,991cc

Max. output 270PS at 1,700rpm

Max. torque 107kg·m at 1,400rpm

HYDRAULIC PUMPS

2 variable piston pumps and 2 variable gear pumps

HYDRAULIC OIL TANK CAPACITY

Upper 2,630 liters

Lower 200 liters

SAFETY DEVICES

Automatic moment limiter (AML)

With working range limiting function

Outrigger extension automatic detector

Front jack grounding automatic detector

Rear jack grounding automatic detector

Weight combination automatic detector

Over-winding cutout device

Dead winding holding device

Cable follower

Hook safety latch

Winch drum lock

Winch drum rotation indicator

Hydraulic safety valve

Hydraulic lock (elevation, telescoping, hoist, jack, jib tilt, dismount)

Swing lock

Boom angle indicator

Level gauge

Front jack overload alarm

EQUIPMENT

Air conditioner (crane cab)

Radio

Fan

Oil cooler

Boom dismount device

Swing frame dismount device

Counterweight dismount device

Iron plate

Automatic engine air removing device

CARRIER SPECIFICATIONS

MANUFACTURER

NISSAN DIESEL MOTOR CO., LTD.

CARRIER MODEL

KC-KL630YN

ENGINE

Model RH10

Type 4-cycle, V10-cylinder, direct-injection,
water-cooled diesel engine

Piston displacement 26,507cc

Max. output 450PS at 2,200rpm

Max. torque 160kg·m at 1,400rpm

CLUTCH

Dry multi-plate diaphragm type

TRANSMISSION

5-forward and 1-reverse speeds (with 2-step sub reducer)

Constant-mesh gear

REDUCER

Spiral bevel gear type (2nd axle) and hypoid gear type
(4th and 5th axles)

Planetary gear 2-stage speed reduction type

FRONT AXLE

1st axle: Reverse-elliot type

2nd axle: Full-floating type, reverse-elliot type

REAR AXLE

3rd, 6th axles: Reverse-elliot type

4th, 5th axles: Full-floating type

SUSPENSION

1st, 2nd axles: Semi-elliptic leaf spring type,
vehicle shaft type

3rd, 6th axles: Hydraulic type

4th, 5th axles: Equalizer beam type

STEERING

Recirculating ball screw type

With linkage power assistance

1st, 2nd, 3rd, 6th axle steering

BRAKE SYSTEM

Service Brake

Foot operated full air brake on 10 wheels, dual air
line system, internal expanding leading and trailing
shoe type.

Parking Brake

Full air brake type spring brake, acting on wheels

Auxiliary Brake

Electro-pneumatic operated exhaust brake

Emergency Brake

Works by applying the parking brake

ELECTRIC SYSTEM

24 V DC. 2 batteries of 115F51 (96Ah)

FUEL TANK CAPACITY

300 liters

CAB

Two-man type

TIRES

Front 14.00-24-24PR

Rear 14.00-24-24PR

STANDARD EQUIPMENT

Car heater

Car radio

Car cooler

GENERAL DATA

DIMENSIONS (CARRIER ONLY)

Overall length 13,510mm

Overall width 3,400mm

Overall height 2,790mm

Wheel base

1,500mm + 2,800mm + 1,950mm + 1,500mm +

1,500mm = 9,250mm

Tread 2,830mm (1st, 2nd, 3rd, 6th axles)

2,540mm (4th, 5th axles)

WEIGHTS (CARRIER ONLY)

Gross vehicle weight

Total 44,950kg

PERFORMANCE (CARRIER ONLY)

Max. traveling speed 60km/h

Gradeability (tan) 0.31

Min. turning radius 11.8m

TOTAL RATED LOADS

1. The total rated loads shown are for the case where the outriggers are set horizontally on firm level ground. The values above the bold lines are based on the crane strength while those below are based on the crane stability.
2. The weights of the slings and hooks are included in the total rated loads shown.
3. The total rated load is based on the actual working radius including the deflection of the boom and jib.
4. The chart below shows the standard hook and number of part lines under each working condition.

A	14.2		17.3	20.3	22.6	31.0	39.4	47.8
			17.3	20.3	23.4	32.6	41.8	51.0
M	360	180	180		130	100	70	
H	17 x 2	17	17		12	9	6	
N	180 x 2	180	180		180	180	80	
O	8 x 2	8	8		8	8	3	
L	2,400 x 2	2,400	2,400		2,400	2,400	1,360	
Remarks	360 sling support, hook support for the top boom (4,150kg)	Attachment sheave for the top boom	Attachment sheave for the top boom					

A= Boom length (m) M= Max. total rated loads (t) H= No. of part-lines
 N= Hook lifting capacity (t) O= No. of sheaves L= Hook weight (kg)

5. Boom length and boom fixing pin
 The boom telescoping order, stroke of each boom, boom length, boom fixing pin condition when the boom and jib are used are as follows.
 - 1) Boom telescoping order and stroke of each boom
 - Extend the boom from the base boom side, and then extend the next boom when the boom is extended by the strokes shown in the following table.
 - Retract the boom from the top boom side, and then retract the next boom when the boom is retracted by the strokes shown in the following table.

Crane service condition	Boom stroke
Boom	9.2m
	8.4m
Fully automatic luffing jib	9.2m
Luffing jib	8.4m

2) Boom length and boom fixing pin status

Boom length (m)				Pin condition when the boom fixing pin is used	Pin inserted
Boom		Fully automatic luffing jib	Luffing jib		Pin removed
100%	91%				Both pin insertion and removal are available.
14.2	14.2	14.2	14.2		
17.3	17.3	---	---		(Boom performance S, A, B, C, D, E only)
20.3	20.3	---	---		(Boom performance S, A, B, C, D, E only)
23.4	22.6	23.4	22.6		
32.6	31.0	32.6	31.0		
41.8	39.4	41.8	39.4		
51.0	47.8	51.0	47.8		

- When the boom is operated, when the boom is extended to the middle, and when at least one boom fixing pin condition marked with \square in the above chart is \square , the performance for the case where the boom fixing pin is not used shall apply.
- When operating the jib (fully automatic luffing jib, luffing jib), the boom length and the boom fixing pin condition must be in accordance with the above chart.

6. As shown in the following table, the performance depends on the outrigger installation condition, counterweight combination, and whether or not the boom fixing pin is used.

1) Performance classification

Counterweight Outrigger extension width	100t	85t	65t	45t	20t	0t	65t on the carrier
	8.8m	S	A	B (D)	C (D)	D (E)	E (F)
7.0m			C (D)	D (D)	E (E)	F (F)	E (E)
5.9m				D (D)	E (E)	F (F)	E (E)
Setting outrigger jacks without extending beams						G (H)	

- If at least either of the front and rear jacks is not used, the performance classification in parentheses shall apply. However, when a 100-ton or 85-ton counterweight is mounted, both of the front and rear jacks should be used.
- Performance F is for the work preparation. The boom length is 14.2m to 23.4m.
- Performance G and H are for crane mounting/demounting operations. The boom length is only 14.2m.
- Mark \square shows the prohibition in order to prevent the crane from falling down on its rear side.

2) Working area

In the following cases, the total rated load varies according to the swing position. Be careful about the AML moment indication (%) because an overload may be applied in some swing directions.

Front and rear jacks used
Left side middle, minimum extended
Right side fully extended

Front and rear jacks used
Right side middle, minimum extended
Left side fully extended

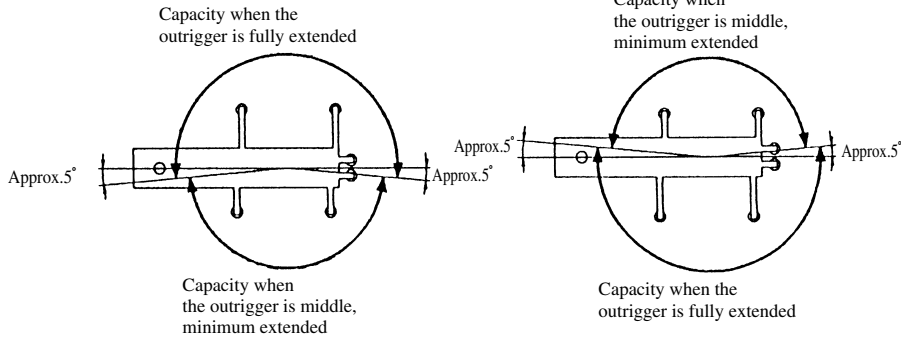

65t counterweight is placed on the carrier.

Setting outrigger jacks without extending beams

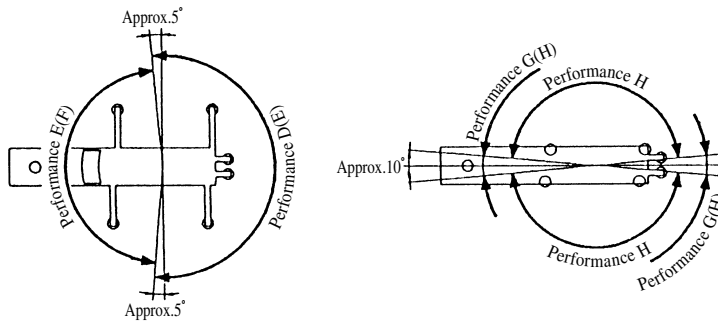

3) When the boom length and the boom fixing pin condition are other than those stated in the chart "Boom length and the boom fixing pin condition" in item 5.2), the maximum total rated load for each boom length is limited as shown in the following table. The total rated loads below the limit value are the same when the boom fixing pin is used. However, when removing the boom fixing pin, the total rated loads for every boom length should be 25 tons or less.

Boom length	Less than 23.4m	Over 23.4m less than 32.6m	Over 32.6m less than 51.0m
Max. total rated load (t)	52.0	50.0	30.0

7. The total rated load for the single top is the same as that of the main boom and must not exceed 12.5 tons. However, when hooks, slings, etc. are mounted on the main boom, work at the total rated load obtained by subtracting the weights of the hooks, slings, etc. mounted on the main boom from the total rated load of the main boom.
8. Do not swing the upper swing frame on tires.
(Keep the swing frame locked until the outrigger is installed.)
9. Mark in the total rated load chart shows the boom angle range (under no load).

TOTAL RATED LOADS

[BOOM]
(Stroke: 8.4m)

Unit: ton

Performance S							
A B	14.2m	17.3m	20.3m	22.6m	31.0m	39.4m	47.8m
3.0m	360.0	180.0	180.0	180.0			
3.5m	305.0	180.0	180.0	180.0			
4.0m	274.0	180.0	180.0	180.0			
4.5m	251.0	180.0	180.0	180.0			
5.0m	231.0	180.0	180.0	180.0	130.0		
6.0m	198.0	180.0	180.0	180.0	130.0	100.0	
7.0m	172.0	169.0	169.0	169.0	130.0	100.0	70.0
8.0m	152.0	149.0	149.0	149.0	127.0	100.0	70.0
9.0m	135.0	132.0	132.0	132.0	116.0	97.8	70.0
10.0m	121.0	118.0	118.0	118.0	107.0	90.1	69.4
11.0m		106.0	106.0	106.0	99.3	83.5	65.2
12.0m		96.1	96.1	96.1	92.2	77.6	61.4
14.0m		79.9	79.9	79.9	80.5	67.9	54.8
16.0m			67.4	67.4	68.4	60.0	48.7
18.0m				56.6	57.6	53.5	43.2
20.0m					48.5	47.9	38.6
22.0m					41.4	43.0	34.9
24.0m					35.6	38.8	32.0
26.0m					30.8	35.0	29.5
28.0m						31.2	27.4
30.0m						28.0	25.5
32.0m						24.7	23.8
34.0m						21.9	22.2
36.0m							20.8
38.0m							19.4
40.0m							17.5
42.0m							15.8
44.0m							14.2
(°)	0 ~ 83	0 ~ 83	0 ~ 83	0 ~ 83	0 ~ 83	0 ~ 83	13 ~ 83

A= Boom length B= Working radius
= Boom angle range (for the unladen condition)

[BOOM]
(Stroke: 8.4m)

Unit: ton

Performance A							
A \ B	14.2m	17.3m	20.3m	22.6m	31.0m	39.4m	47.8m
3.0m	360.0	180.0	180.0	180.0			
3.5m	300.0	180.0	180.0	180.0			
4.0m	260.0	180.0	180.0	180.0			
4.5m	240.0	180.0	180.0	180.0			
5.0m	225.0	180.0	180.0	180.0	130.0		
6.0m	190.0	180.0	180.0	180.0	130.0	100.0	
7.0m	163.0	163.0	163.0	163.0	130.0	100.0	70.0
8.0m	143.0	142.0	142.0	142.0	127.0	100.0	70.0
9.0m	125.0	126.0	126.0	126.0	116.0	97.8	70.0
10.0m	110.0	112.0	112.0	112.0	107.0	90.1	69.4
11.0m		101.0	101.0	101.0	99.3	83.5	65.2
12.0m		91.4	91.4	91.4	92.2	77.6	61.4
14.0m		75.7	75.7	75.7	76.8	67.9	54.8
16.0m			61.4	61.4	62.5	60.0	48.7
18.0m				50.6	51.6	53.5	43.2
20.0m					43.2	46.0	38.6
22.0m					36.6	40.0	34.9
24.0m					31.3	34.5	32.0
26.0m					26.9	29.5	29.5
28.0m						26.0	27.4
30.0m						22.9	24.5
32.0m						20.2	22.0
34.0m						17.8	19.8
36.0m							17.5
38.0m							15.7
40.0m							14.0
42.0m							12.5
44.0m							11.0
(°)	0 ~ 83	0 ~ 83	0 ~ 83	0 ~ 83	0 ~ 83	0 ~ 83	13 ~ 83

A= Boom length B= Working radius
= Boom angle range (for the unladen condition)

[BOOM]
(Stroke: 8.4m)

Unit: ton

Performance B							
A \ B	14.2m	17.3m	20.3m	22.6m	31.0m	39.4m	47.8m
3.0m	360.0	180.0	180.0	180.0			
3.5m	300.0	180.0	180.0	180.0			
4.0m	260.0	180.0	180.0	180.0			
4.5m	240.0	180.0	180.0	180.0			
5.0m	225.0	180.0	180.0	180.0	130.0		
6.0m	190.0	176.0	176.0	176.0	130.0	100.0	
7.0m	159.0	152.0	152.0	152.0	130.0	100.0	70.0
8.0m	136.0	132.0	132.0	132.0	127.0	100.0	70.0
9.0m	118.0	116.0	116.0	116.0	116.0	97.8	70.0
10.0m	104.0	103.0	103.0	103.0	104.0	90.1	69.4
11.0m		92.8	92.8	92.8	93.9	83.5	65.2
12.0m		81.1	81.1	81.1	82.4	77.6	61.4
14.0m		62.9	62.9	62.9	64.0	66.5	54.8
16.0m			50.2	50.2	51.2	57.0	48.7
18.0m				40.8	41.8	47.0	43.2
20.0m					34.6	38.9	38.6
22.0m					28.9	32.2	33.8
24.0m					24.3	27.0	29.4
26.0m					20.4	23.0	25.2
28.0m						19.5	21.7
30.0m						16.7	18.9
32.0m						14.2	16.6
34.0m						12.0	14.5
36.0m							12.6
38.0m							10.7
40.0m							9.1
42.0m							7.7
44.0m							6.4
(°)	0 ~ 83	0 ~ 83	0 ~ 83	0 ~ 83	0 ~ 83	0 ~ 83	13 ~ 83

A= Boom length B= Working radius
= Boom angle range (for the unladen condition)

[BOOM]
(Stroke: 8.4m)

Unit: ton

Performance C							
A \ B	14.2m	17.3m	20.3m	22.6m	31.0m	39.4m	47.8m
3.0m	320.0	180.0	180.0	180.0			
3.5m	265.0	180.0	180.0	180.0			
4.0m	235.0	180.0	180.0	180.0			
4.5m	215.0	180.0	180.0	180.0			
5.0m	200.0	180.0	180.0	180.0	130.0		
6.0m	170.0	164.0	164.0	164.0	130.0	100.0	
7.0m	143.0	140.0	140.0	140.0	130.0	100.0	70.0
8.0m	122.0	122.0	122.0	122.0	123.0	100.0	70.0
9.0m	106.0	107.0	107.0	107.0	108.0	97.8	70.0
10.0m	94.0	90.6	90.6	90.6	92.0	90.1	69.4
11.0m		77.0	77.0	77.0	78.3	81.0	65.2
12.0m		66.3	66.3	66.3	67.6	70.2	61.4
14.0m		50.7	50.7	50.7	51.8	54.3	54.8
16.0m			39.8	39.8	40.9	43.2	46.0
18.0m				31.1	32.2	34.6	37.5
20.0m					25.6	27.9	30.7
22.0m					20.5	22.7	25.4
24.0m					16.4	18.5	21.2
26.0m					13.2	15.2	17.7
28.0m						12.4	14.9
30.0m						10.1	12.5
32.0m						7.9	10.4
34.0m						5.9	8.7
36.0m							7.0
38.0m							5.4
40.0m							4.0
42.0m							2.8
(°)	0 ~ 83	0 ~ 83	0 ~ 83	0 ~ 83	0 ~ 83	0 ~ 83	16 ~ 83

A= Boom length B= Working radius
= Boom angle range (for the unladen condition)

[BOOM]
(Stroke: 8.4m)

Unit: ton

Performance D							
A \ B	14.2m	17.3m	20.3m	22.6m	31.0m	39.4m	47.8m
3.0m	250.0	180.0	180.0	180.0			
3.5m	221.0	180.0	180.0	180.0			
4.0m	198.0	180.0	180.0	180.0			
4.5m	178.0	175.0	175.0	175.0			
5.0m	162.0	159.0	159.0	159.0	130.0		
6.0m	135.0	132.0	132.0	132.0	130.0	100.0	
7.0m	115.0	112.0	112.0	112.0	122.0	100.0	70.0
8.0m	97.2	92.8	92.8	92.8	94.5	97.7	70.0
9.0m	78.1	74.0	74.0	74.0	75.5	78.5	70.0
10.0m	64.5	60.5	60.5	60.5	61.9	64.7	68.1
11.0m		50.3	50.3	50.3	51.7	54.3	57.6
12.0m		42.4	42.4	42.4	43.7	46.3	49.4
14.0m		31.0	31.0	31.0	32.1	34.5	37.5
16.0m			22.9	22.9	24.1	26.4	29.2
18.0m				16.6	17.7	20.1	23.1
20.0m					12.9	15.2	18.0
22.0m					9.2	11.4	14.2
24.0m					6.3	8.4	11.1
26.0m					3.5	6.0	8.6
28.0m						3.7	6.5
30.0m							4.7
(°)	0 ~ 83	0 ~ 83	0 ~ 83	0 ~ 83	21 ~ 83	40 ~ 83	49 ~ 83

A= Boom length B= Working radius
= Boom angle range (for the unladen condition)

[BOOM]
(Stroke: 8.4m)

Unit: ton

Performance E							
B \ A	14.2m	17.3m	20.3m	22.6m	31.0m	39.4m	47.8m
3.0m	200.0	180.0	180.0	180.0			
3.5m	180.0	180.0	180.0	180.0			
4.0m	165.0	173.0	173.0	173.0			
4.5m	150.0	154.0	154.0	154.0			
5.0m	140.0	139.0	139.0	139.0	130.0		
6.0m	120.0	110.0	110.0	110.0	113.0	100.0	
7.0m	80.0	78.3	78.3	78.3	80.1	83.7	70.0
8.0m	62.0	58.5	58.5	58.5	60.2	63.4	67.4
9.0m	48.0	45.3	45.3	45.3	46.9	49.9	53.5
10.0m	40.0	35.9	35.9	35.9	37.3	40.2	43.6
11.0m		28.8	28.8	28.8	30.2	32.8	36.1
12.0m		23.3	23.3	23.3	24.6	27.2	30.3
14.0m		15.3	15.3	15.3	16.5	18.9	21.8
16.0m			9.6	9.6	10.8	13.2	15.9
18.0m				5.2	6.3	8.8	11.6
20.0m							8.2
(°)	0 ~ 83	0 ~ 83	0 ~ 83	13 ~ 83	50 ~ 83	60 ~ 83	63 ~ 83

Unit: ton

Performance F		
B \ A	14.2m	22.6m
3.0m	160.0	145.0
3.5m	145.0	145.0
4.0m	130.0	130.0
4.5m	115.0	115.0
5.0m	104.0	100.0
6.0m	64.0	66.0
7.0m	44.0	44.0
8.0m	31.0	31.0
9.0m	24.0	21.0
10.0m	18.0	14.0
11.0m		9.0
(°)	23 ~ 83	54 ~ 83

A= Boom length B= Working radius
= Boom angle range (for the unladen condition)

[BOOM]
(Stroke: 9.2m)

Unit: ton

Performance S							
A \ B	14.2m	17.3m	20.3m	23.4m	32.6m	41.8m	51.0m
3.0m	360.0	180.0	180.0	180.0			
3.5m	305.0	180.0	180.0	180.0			
4.0m	274.0	180.0	180.0	180.0			
4.5m	251.0	180.0	180.0	180.0			
5.0m	231.0	180.0	180.0	180.0	130.0		
6.0m	198.0	180.0	180.0	180.0	130.0	100.0	
7.0m	172.0	169.0	169.0	169.0	128.0	100.0	70.0
8.0m	152.0	148.0	148.0	148.0	116.0	94.2	68.8
9.0m	135.0	131.0	131.0	131.0	106.0	86.2	65.0
10.0m	121.0	117.0	117.0	117.0	97.9	79.4	60.6
11.0m		106.0	106.0	106.0	90.4	73.5	56.8
12.0m		95.9	95.9	95.9	83.8	68.3	53.3
14.0m		79.6	79.6	79.6	73.0	59.2	47.5
16.0m			67.1	67.1	64.3	51.9	42.7
18.0m				56.3	57.2	46.0	38.4
20.0m				47.4	48.3	41.0	34.6
22.0m					41.2	36.9	31.4
24.0m					35.4	33.3	28.6
26.0m					30.6	30.3	26.1
28.0m					26.7	27.6	23.9
30.0m						25.2	21.9
32.0m						23.2	20.2
34.0m						21.4	18.7
36.0m						19.3	17.3
38.0m						17.2	16.1
40.0m							15.0
42.0m							14.0
44.0m							13.1
46.0m							12.1
(°)	0 ~ 83	0 ~ 83	0 ~ 83	0 ~ 83	0 ~ 83	0 ~ 83	17 ~ 83

A= Boom length B= Working radius
= Boom angle range (for the unladen condition)

[BOOM]
(Stroke: 9.2m)

Unit: ton

Performance A							
A \ B	14.2m	17.3m	20.3m	23.4m	32.6m	41.8m	51.0m
3.0m	360.0	180.0	180.0	180.0			
3.5m	300.0	180.0	180.0	180.0			
4.0m	260.0	180.0	180.0	180.0			
4.5m	240.0	180.0	180.0	180.0			
5.0m	225.0	180.0	180.0	180.0	130.0		
6.0m	190.0	180.0	180.0	180.0	130.0	100.0	
7.0m	163.0	162.0	162.0	162.0	128.0	100.0	70.0
8.0m	143.0	142.0	142.0	142.0	116.0	94.2	68.8
9.0m	125.0	126.0	126.0	126.0	106.0	86.2	65.0
10.0m	110.0	112.0	112.0	112.0	97.9	79.4	60.6
11.0m		101.0	101.0	101.0	90.4	73.5	56.8
12.0m		91.2	91.2	91.2	83.8	68.3	53.3
14.0m		75.4	75.4	75.4	73.0	59.2	47.5
16.0m			61.1	61.1	62.3	51.9	42.7
18.0m				50.3	51.4	46.0	38.4
20.0m				42.1	43.0	41.0	34.6
22.0m					36.4	36.9	31.4
24.0m					31.1	33.3	28.6
26.0m					26.7	30.3	26.1
28.0m					23.1	26.0	23.9
30.0m						22.9	21.9
32.0m						20.2	20.2
34.0m						18.0	18.7
36.0m						15.8	16.6
38.0m						13.9	14.8
40.0m							13.2
42.0m							11.8
44.0m							10.6
46.0m							9.6
(°)	0 ~ 83	0 ~ 83	0 ~ 83	0 ~ 83	0 ~ 83	0 ~ 83	17 ~ 83

A= Boom length B= Working radius
= Boom angle range (for the unladen condition)

[BOOM]
(Stroke: 9.2m)

Unit: ton

Performance B							
A \ B	14.2m	17.3m	20.3m	23.4m	32.6m	41.8m	51.0m
3.0m	360.0	180.0	180.0	180.0			
3.5m	300.0	180.0	180.0	180.0			
4.0m	260.0	180.0	180.0	180.0			
4.5m	240.0	180.0	180.0	180.0			
5.0m	225.0	180.0	180.0	180.0	130.0		
6.0m	190.0	176.0	176.0	176.0	130.0	100.0	
7.0m	159.0	151.0	151.0	151.0	128.0	100.0	70.0
8.0m	136.0	132.0	132.0	132.0	116.0	94.2	68.8
9.0m	118.0	116.0	116.0	116.0	106.0	86.2	65.0
10.0m	104.0	103.0	103.0	103.0	97.9	79.4	60.6
11.0m		92.5	92.5	92.5	90.4	73.5	56.8
12.0m		80.9	80.9	80.9	82.2	68.3	53.3
14.0m		62.6	62.6	62.6	63.8	59.2	47.5
16.0m			49.9	49.9	51.0	51.9	42.7
18.0m				40.6	41.6	45.0	38.4
20.0m				33.5	34.4	38.2	34.6
22.0m					28.7	32.2	31.6
24.0m					24.1	27.0	28.6
26.0m					20.2	22.8	25.2
28.0m					16.9	19.2	21.9
30.0m						16.6	19.0
32.0m						14.2	16.4
34.0m						12.1	14.2
36.0m						10.2	12.4
38.0m						8.5	10.8
40.0m							9.3
42.0m							7.8
44.0m							6.5
46.0m							5.4
(°)	0 ~ 83	0 ~ 83	0 ~ 83	0 ~ 83	0 ~ 83	0 ~ 83	17 ~ 83

A= Boom length B= Working radius
= Boom angle range (for the unladen condition)

[BOOM]
(Stroke: 9.2m)

Unit: ton

Performance C							
A \ B	14.2m	17.3m	20.3m	23.4m	32.6m	41.8m	51.0m
3.0m	320.0	180.0	180.0	180.0			
3.5m	265.0	180.0	180.0	180.0			
4.0m	235.0	180.0	180.0	180.0			
4.5m	215.0	180.0	180.0	180.0			
5.0m	200.0	180.0	180.0	180.0	130.0		
6.0m	170.0	164.0	164.0	164.0	130.0	100.0	
7.0m	143.0	140.0	140.0	140.0	128.0	100.0	70.0
8.0m	122.0	122.0	122.0	122.0	116.0	94.2	68.8
9.0m	106.0	107.0	107.0	107.0	106.0	86.2	65.0
10.0m	94.0	90.3	90.3	90.3	91.8	79.4	60.6
11.0m		76.7	76.7	76.7	78.1	73.5	56.8
12.0m		66.0	66.0	66.0	67.3	68.3	53.3
14.0m		50.4	50.4	50.4	51.6	54.2	47.5
16.0m			39.5	39.5	40.7	43.1	42.7
18.0m				30.8	32.0	34.5	37.5
20.0m				24.4	25.4	27.8	30.7
22.0m					20.3	22.6	25.4
24.0m					16.2	18.4	21.1
26.0m					12.9	15.1	17.7
28.0m					10.3	12.3	14.8
30.0m						9.9	12.4
32.0m						7.8	10.4
34.0m						5.7	8.6
36.0m						4.0	6.9
38.0m						2.5	5.3
40.0m							3.9
42.0m							2.7
(°)	0 ~ 83	0 ~ 83	0 ~ 83	0 ~ 83	0 ~ 83	15 ~ 83	27 ~ 83

A= Boom length B= Working radius
= Boom angle range (for the unladen condition)

[BOOM]
(Stroke: 9.2m)

Unit: ton

Performance D							
A \ B	14.2m	17.3m	20.3m	23.4m	32.6m	41.8m	51.0m
3.0m	250.0	180.0	180.0	180.0			
3.5m	221.0	180.0	180.0	180.0			
4.0m	198.0	180.0	180.0	180.0			
4.5m	178.0	175.0	175.0	175.0			
5.0m	162.0	159.0	159.0	159.0	130.0		
6.0m	135.0	132.0	132.0	132.0	130.0	100.0	
7.0m	115.0	112.0	112.0	112.0	113.0	100.0	70.0
8.0m	97.2	92.5	92.5	92.5	94.2	94.2	68.8
9.0m	78.1	73.6	73.6	73.6	75.2	78.3	65.0
10.0m	64.5	60.2	60.2	60.2	61.6	64.5	60.6
11.0m		50.0	50.0	50.0	51.4	54.2	56.8
12.0m		42.2	42.2	42.2	43.5	46.1	49.3
14.0m		30.7	30.7	30.7	31.9	34.4	37.4
16.0m			22.6	22.6	23.9	26.3	29.2
18.0m				16.3	17.5	20.0	23.0
20.0m				11.7	12.7	15.1	18.0
22.0m					9.0	11.3	14.1
24.0m					6.1	8.3	11.0
26.0m					3.2	5.9	8.5
28.0m							6.4
30.0m							4.7
(°)	0 ~ 83	0 ~ 83	0 ~ 83	0 ~ 83	29 ~ 83	47 ~ 83	52 ~ 83

A= Boom length B= Working radius
= Boom angle range (for the unladen condition)

[BOOM]
(Stroke: 9.2m)

Unit: ton

Performance E							
B \ A	14.2m	17.3m	20.3m	23.4m	32.6m	41.8m	51.0m
3.0m	200.0	180.0	180.0	180.0			
3.5m	180.0	180.0	180.0	180.0			
4.0m	165.0	172.0	172.0	172.0			
4.5m	150.0	154.0	154.0	154.0			
5.0m	140.0	139.0	139.0	139.0	130.0		
6.0m	120.0	110.0	110.0	110.0	112.0	100.0	
7.0m	80.0	77.9	77.9	77.9	79.8	83.5	70.0
8.0m	62.0	58.2	58.2	58.2	59.9	63.3	67.3
9.0m	48.0	45.0	45.0	45.0	46.6	49.7	53.4
10.0m	40.0	35.6	35.6	35.6	37.1	40.0	43.5
11.0m		28.5	28.5	28.5	29.9	32.7	36.0
12.0m		23.0	23.0	23.0	24.4	27.0	30.2
14.0m		15.0	15.0	15.0	16.3	18.8	21.8
16.0m			9.3	9.3	10.6	13.0	15.9
18.0m				4.9	6.1	8.7	11.6
20.0m							8.1
(°)	0 ~ 83	0 ~ 83	0 ~ 83	29 ~ 83	52 ~ 83	62 ~ 83	65 ~ 83

Unit: ton

Performance F		
B \ A	14.2m	23.4m
3.0m	160.0	145.0
3.5m	145.0	145.0
4.0m	130.0	130.0
4.5m	115.0	115.0
5.0m	104.0	100.0
6.0m	64.0	66.0
7.0m	44.0	44.0
8.0m	31.0	31.0
9.0m	24.0	21.0
10.0m	18.0	14.0
11.0m		9.0
(°)	23 ~ 83	55 ~ 83

Unit: ton

Performance G	
B \ A	14.2m
3.0m	7.0
3.5m	7.0
4.0m	7.0
4.5m	7.0
5.0m	7.0
6.0m	7.0
7.0m	7.0
8.0m	7.0
9.0m	7.0
10.0m	7.0
(°)	23 ~ 83

Unit: ton

Performance H	
B \ A	14.2m
3.0m	7.0
3.5m	7.0
4.0m	7.0
4.5m	7.0
5.0m	7.0
6.0m	7.0
7.0m	7.0
8.0m	6.0
9.0m	4.0
10.0m	1.5
(°)	37 ~ 83

A= Boom length B= Working radius
= Boom angle range (for the unladen condition)

WORKING RADIUS - LIFTING HEIGHT

BOOM (each section stroke: 8.4m)

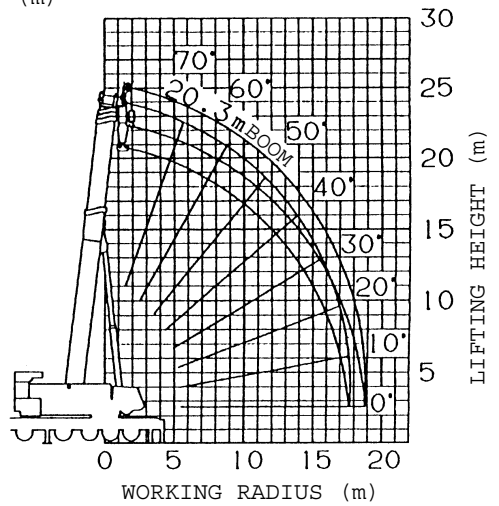
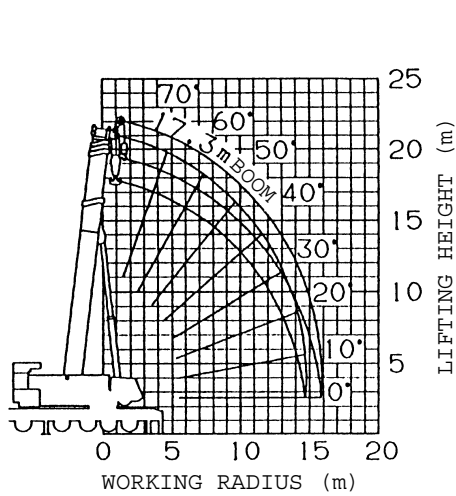
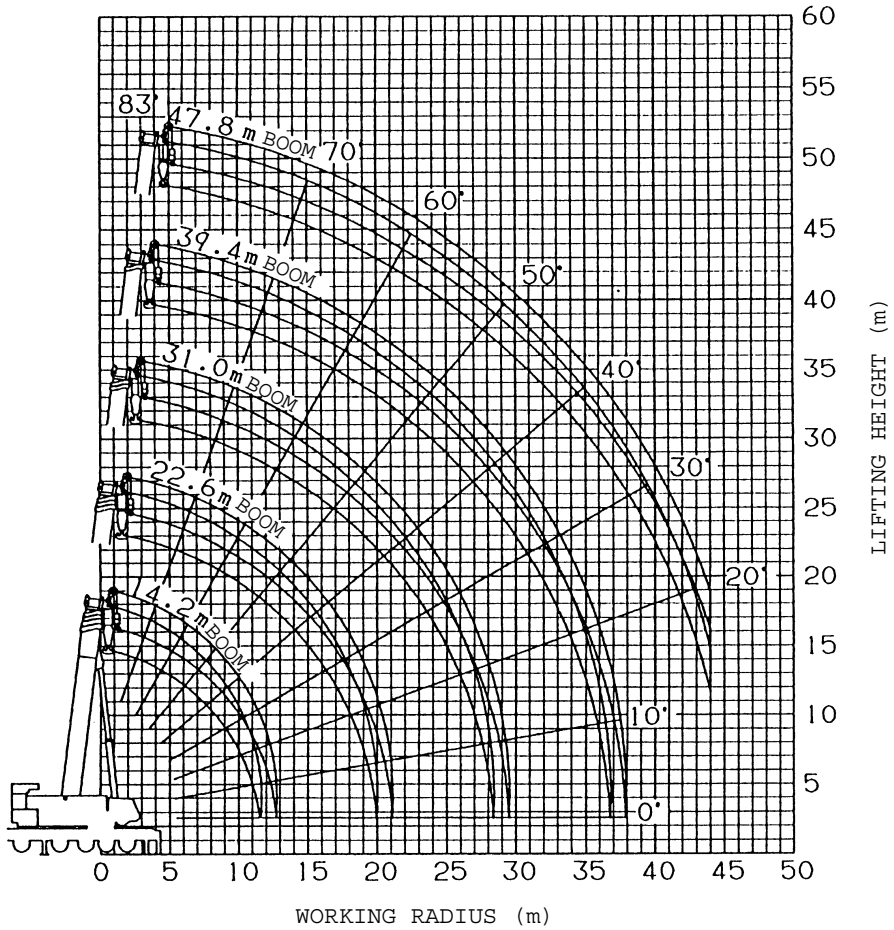

NOTES:

1. The deflection of the boom is not incorporated in the figure above.
2. The above charts show the maximum working radii of performance S, A and B.

WORKING RADIUS - LIFTING HEIGHT

BOOM (each section stroke: 9.2m)

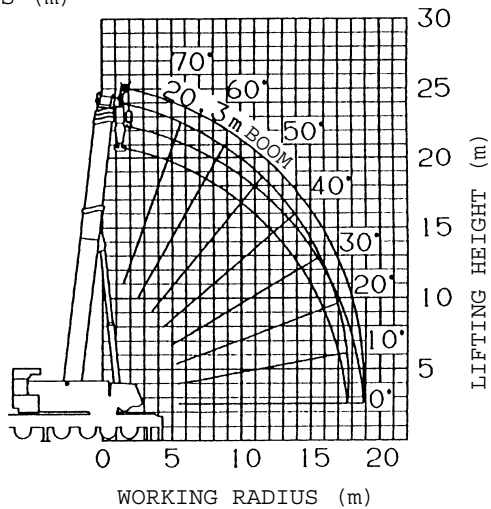
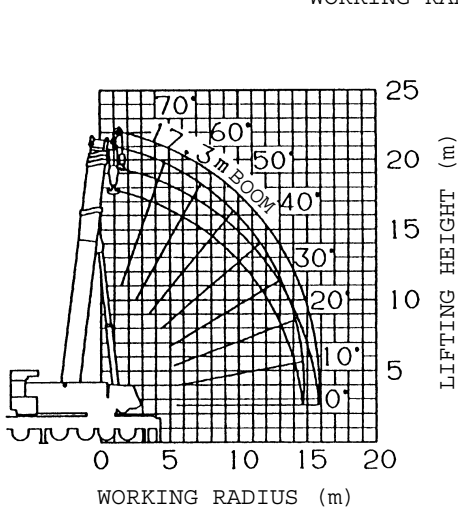
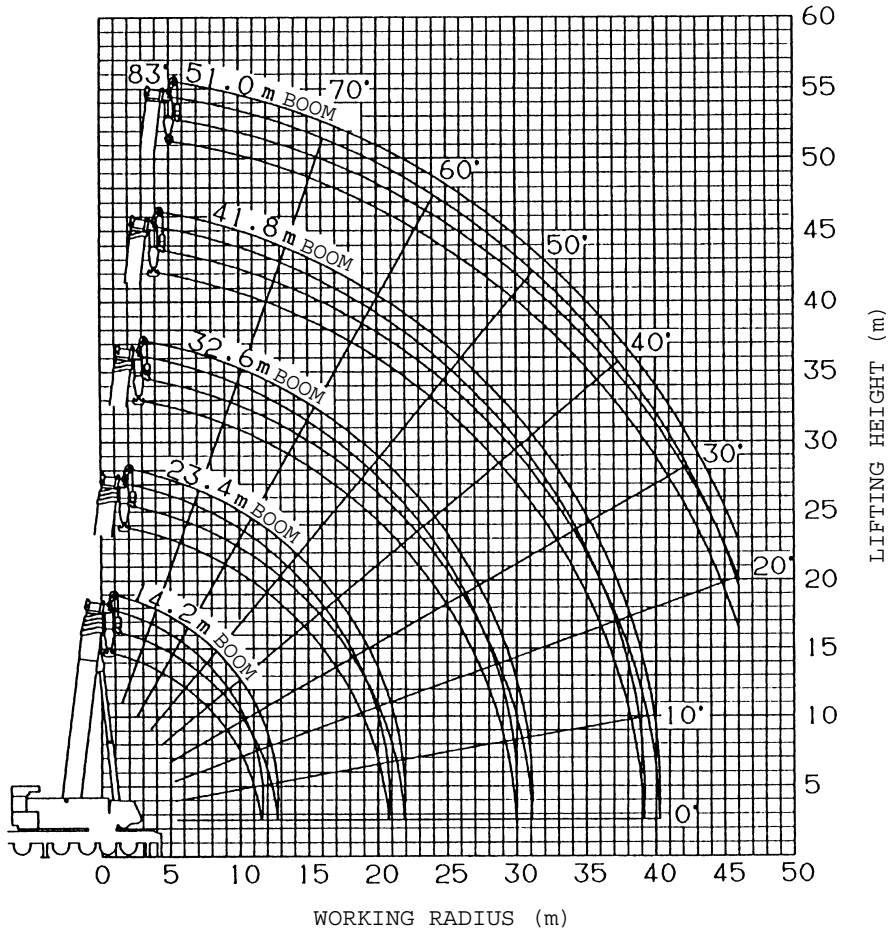

NOTES:

1. The deflection of the boom is not incorporated in the figure above.
2. The above charts show the maximum working radii of performance S, A and B.

DIMENSIONS (1/100) [On-site traveling condition]

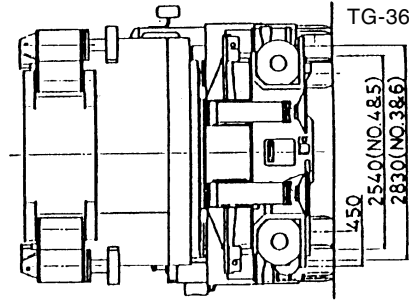
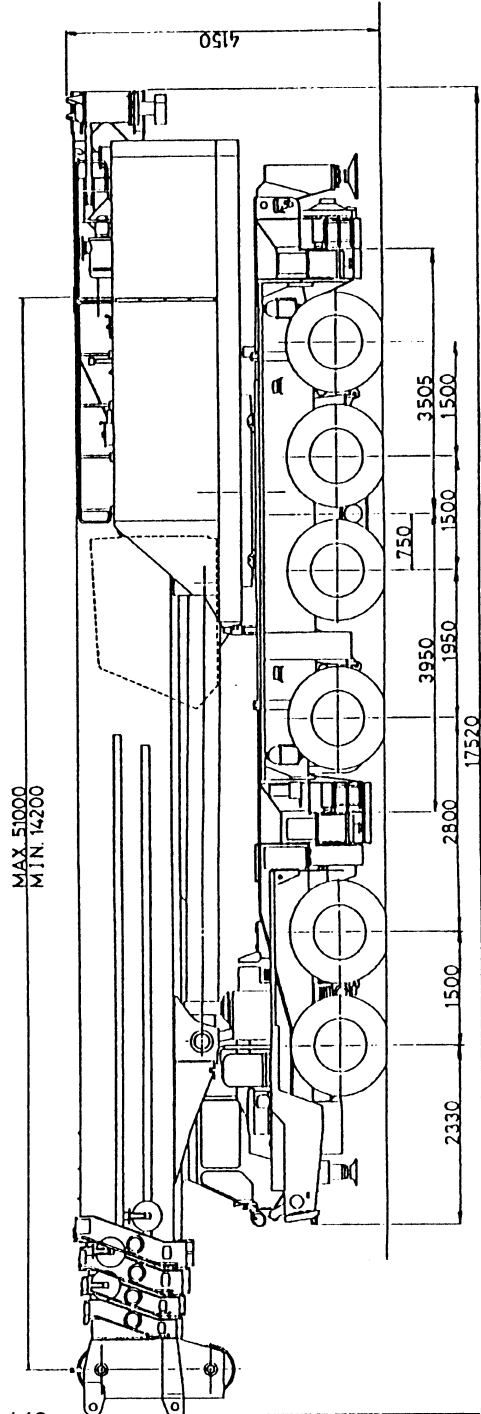
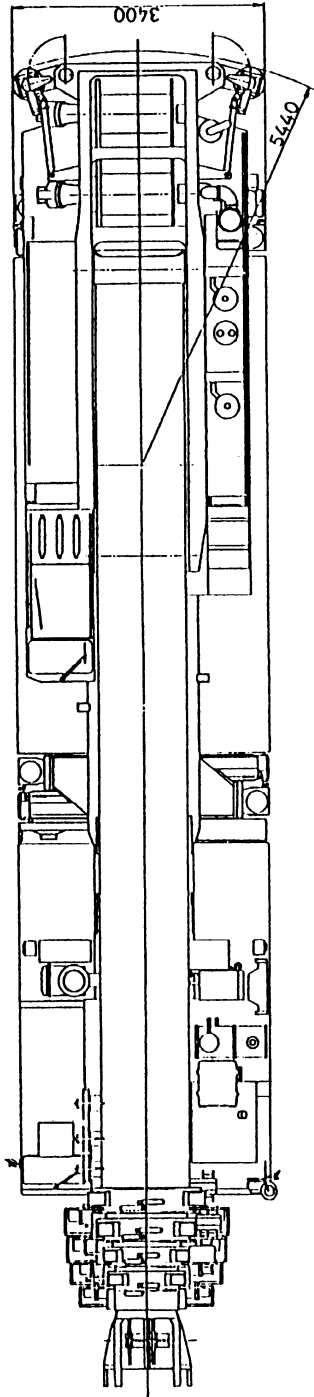

TG-3600M-2/MB-90

TRUCK CRANE

TG-3600M

JAPANESE SPECIFICATIONS

TG

These specifications are for the optional fully automatic luffing jib for the TG-3600M type crane. Refer to these specifications along with specification control no. TG-3600M-2/MB-80.

Control No. TG-3600M-2/FLJ-80

TG-3600M

CRANE SPECIFICATIONS

CRANE CAPACITY

11.1m	Jib	54,000kg	at 10.0m (5part-line)
19.1m	Jib	29,000kg	at 8.0m (3part-line)
27.1m	Jib	10,000kg	at 22.0m (1part-line)
35.1m	Jib	9,500kg	at 16.0m (1part-line)

Jib

4-section hydraulically telescoping boom of hexagonal box construction
(stage 2: sequential; stages 3,4: synchronized)

Hydraulic non-stage offset (0 °- 40 °) type

1.7m (fixed part) + 11.1m – 35.1m (elevating/telescoping part)

JIB LENGTH

11.1m
19.1m
27.1m
35.1m

MAX.LIFTING HEIGHT

88.0m

MAX.WORKING RADIUS

70.0m

TOTAL RATED LOADS

1. The total rated loads shown are for the case where the outriggers are set horizontally on firm level ground. The values above the bold lines are based on the crane strength while those below are based on the crane stability.
2. The weights of the slings and hooks are included in the total rated loads shown.
3. The total rated load is based on the actual working radius including the deflection of the boom and jib.
4. The chart below shows the standard hook and number of part lines under each working condition.

A	11.1	19.1	27.1	35.1
M	54.0	29.0	10.0	9.5
H	5	3	1	1
N	80	80	12.5	12.5
O	3	3	—	—
L	1,360	1,360	490	490

A= Boom length (m) M= Max. total rated loads (t) H= No. of part-lines
 N= Hook lifting capacity (t) O= No. of sheaves L= Hook weight (kg)

5. Boom length and boom fixing pin
 The boom telescoping order, stroke of each boom, boom length, boom fixing pin condition when the boom and jib are used are as follows.
 - 1) Boom telescoping order and stroke of each boom
 - Extend the boom from the base boom side, and then extend the next boom when the boom is extended by the strokes shown in the following table.
 - Retract the boom from the top boom side, and then retract the next boom when the boom is retracted by the strokes shown in the following table.

Crane service condition	Boom stroke
Boom	9.2m
Fully automatic luffing jib	

2) Boom length and boom fixing pin status

Boom length (m)		Pin condition when the boom fixing pin is used	● Pin inserted
• Boom • Fully automatic luffing jib	• Boom • Luffing jib		○ Pin removed
			◐ Both pin insertion and removal are available.
14.2	14.2		
23.4	22.6		
32.6	31.0		
41.8	39.4		
51.0	47.8		

- When the boom is operated, when the boom is extended to the middle, and when at least one boom fixing pin condition marked with ◐ in the above chart is ◐, the performance for the case where the boom fixing pin is not used shall apply.
- When operating the jib (fully automatic luffing jib, luffing jib), the boom length and the boom fixing pin condition must be in accordance with the above chart.

6. As shown in the following table, the performance depends on the outrigger installation condition and counterweight combination.

Counterweight	85t	65t	45t	20t
Outrigger extension width				
8.8m	A	B	C	D
7.0m		C	D	

- Both of the front and rear jacks should be used.
- The boom fixing pin should be used.

7. Mark ◐ in the total rated load chart shows the boom angle range (under no load).

[14.2m Boom + 1.7m + Fully automatic luffing jib]
Performance A

D (°) B (m)		11.1m Jib				Unit: ton
		0	15	30	40	
5	54.0	41.3				
6	54.0	37.3				
7	47.3	34.0	26.6			
8	41.9	31.2	24.9			
9	37.6	28.8	23.4	21.0		
10	34.0	26.7	22.1	19.9		
12	28.4	23.2	19.8	18.2		
14	24.2	20.5	18.0	16.8		
16	21.0	18.3	16.5	15.6		
18	18.5	16.6	15.3	14.8		
20	16.4	15.1	14.3	14.2		
22	14.6	13.9	13.7			
24	13.2					
(°)	0 ~ 83	28 ~ 83	29 ~ 83	42 ~ 83	42 ~ 83	

D (°) B (m)		19.1m Jib				Unit: ton
		0	15	30	40	
8	25.5					
9	23.6	18.0				
10	21.9	16.9				
12	19.0	15.0				
14	16.6	13.5	11.3			
16	14.7	12.2	10.4	9.5		
18	13.2	11.2	9.7	8.9		
20	11.9	10.2	8.9	8.3		
22	10.5	9.2	8.2	7.7		
24	9.4	8.4	7.6	7.2		
26	8.4	7.6	7.0	6.8		
28	7.5	7.0	6.6	6.5		
30	6.8	6.5				
32	6.1					
(°)	0 ~ 83	29 ~ 83	42 ~ 83	43 ~ 83	43 ~ 83	

D (°) B (m)		27.1m Jib				Unit: ton
		0	15	30	40	
8	10.0					
9	10.0					
10	10.0					
12	10.0	9.5				
14	10.0	8.5				
16	9.4	7.6				
18	8.3	6.9	5.8			
20	7.4	6.3	5.4			
22	6.7	5.7	5.0	4.6		
24	6.1	5.3	4.6	4.3		
26	5.6	4.9	4.3	4.0		
28	5.1	4.5	4.1	3.8		
30	4.7	4.2	3.8	3.6		
32	4.3	4.0	3.6	3.5		
34	4.0	3.7	3.5	3.3		
36	3.8	3.5	3.3	3.3		
38	3.5	3.4	3.3			
40	3.3					
(°)	0 ~ 83	31 ~ 83	36 ~ 83	47 ~ 83	47 ~ 83	

D (°) B (m)		35.1m Jib				Unit: ton
		0	15	30	40	
10	9.5					
12	9.2					
14	8.0					
16	7.0	5.7				
18	6.3	5.1				
20	5.6	4.6				
22	5.0	4.2				
24	4.5	3.9	3.3			
26	4.1	3.5	3.1			
28	3.7	3.3	2.8	2.6		
30	3.4	3.0	2.6	2.4		
32	3.1	2.8	2.5	2.3		
34	2.9	2.6	2.3	2.1		
36	2.7	2.4	2.2	2.0		
38	2.5	2.2	2.0	1.9		
40	2.3	2.1	1.9	1.8		
42	2.1	1.9	1.8	1.7		
44	2.0	1.8	1.7	1.7		
46	1.8	1.7	1.7			
48	1.7					
(°)	0 ~ 83	33 ~ 83	41 ~ 83	51 ~ 83	51 ~ 83	

B= Working radius

D= Jib offset

= Boom angle range (for the unladen condition)

[23.4m Boom + 1.7m + Fully automatic luffing jib]
Performance A

11.1m Jib					Unit: ton		
D (°)	B (m)	0	15	30	40		
		6	54.0				
7	54.0	39.4					
8	54.0	36.6					
9	52.1	34.2	25.6				
10	47.3	32.0	24.4				
12	39.7	28.4	22.3	19.8			
14	34.0	25.5	20.6	18.5			
16	29.7	23.1	19.1	17.4			
18	26.2	21.0	17.9	16.5			
20	23.4	19.3	16.8	15.7			
22	21.1	17.9	15.9	15.1			
24	19.1	16.6	15.1	14.6			
26	17.4	15.5	14.4	14.2			
28	16.0	14.6	13.9				
30	14.7	13.8					
32	13.6	13.2					
(°)	16~83	18~83	38~83	45~83			

19.1m Jib					Unit: ton		
D (°)	B (m)	0	15	30	40		
		8	29.0				
9	27.2						
10	25.5						
12	22.6	16.4					
14	20.2	14.9					
16	18.0	13.7	11.1				
18	16.2	12.7	10.4	9.3			
20	14.7	11.8	9.8	8.9			
22	13.5	11.0	9.3	8.5			
24	12.4	10.3	8.8	8.0			
26	11.5	9.7	8.3	7.6			
28	10.6	9.0	7.8	7.2			
30	9.7	8.3	7.3	6.9			
32	8.9	7.7	7.0	6.7			
34	8.1	7.2	6.7	6.5			
36	7.5	6.8	6.4				
38	6.9	6.4					
40	6.4	6.1					
(°)	16~83	20~83	39~83	46~83			

27.1m Jib					Unit: ton		
D (°)	B (m)	0	15	30	40		
		8	10.0				
9	10.0						
10	10.0						
12	10.0						
14	10.0						
16	10.0	8.2					
18	9.8	7.5					
20	8.9	6.9	5.6				
22	8.1	6.4	5.2				
24	7.4	5.9	4.9	4.4			
26	6.8	5.5	4.7	4.2			
28	6.2	5.2	4.4	4.0			
30	5.8	4.9	4.2	3.9			
32	5.4	4.6	4.0	3.7			
34	5.0	4.3	3.8	3.6			
36	4.7	4.1	3.7	3.5			
38	4.4	3.9	3.5	3.4			
40	4.1	3.7	3.4	3.3			
42	3.9	3.5	3.3	3.2			
44	3.7	3.4	3.2				
46	3.5	3.3	3.2				
48	3.3	3.2					
(°)	16~83	23~83	35~83	49~83			

35.1m Jib					Unit: ton		
D (°)	B (m)	0	15	30	40		
		10	9.5				
12	9.5						
14	8.8						
16	7.8						
18	7.0						
20	6.4	4.9					
22	5.8	4.5					
24	5.3	4.2					
26	4.8	3.9					
28	4.4	3.6	3.0				
30	4.1	3.4	2.8				
32	3.8	3.1	2.6	2.4			
34	3.5	2.9	2.5	2.2			
36	3.2	2.7	2.4	2.1			
38	3.0	2.6	2.2	2.0			
40	2.8	2.4	2.1	1.9			
42	2.6	2.3	2.0	1.9			
44	2.5	2.2	1.9	1.8			
46	2.3	2.0	1.8	1.7			
48	2.2	1.9	1.8	1.7			
50	2.0	1.8	1.7	1.6			
52	1.9	1.8	1.6	1.6			
54	1.8	1.7	1.6				
56	1.7	1.6					
(°)	17~83	26~83	38~83	46~83			

B= Working radius

D= Jib offset

= Boom angle range (for the unladen condition)

[32.6m Boom + 1.7m + Fully automatic luffing jib]
Performance A

D (°) B (m)		11.1m Jib				Unit: ton
		0	15	30	40	
9	54.0	38.2				
10	54.0	36.1				
12	51.0	32.5	24.0			
14	43.9	29.5	22.4	19.6		
16	38.4	26.9	21.0	18.7		
18	34.0	24.8	19.8	17.8		
20	30.5	22.9	18.7	17.0		
22	27.5	21.3	17.8	16.3		
24	25.0	19.9	16.9	15.7		
26	22.9	18.7	16.2	15.2		
28	21.1	17.6	15.5	14.8		
30	19.5	16.6	14.9	14.4		
32	16.8	15.7	14.4	14.1		
34	14.4	15.0	14.0			
36	12.2	12.9	13.2			
38	10.4	10.8				
40	8.4	8.8				
42	6.7					
(°)	9 ~ 83	23 ~ 83	37 ~ 83	47 ~ 83		

D (°) B (m)		19.1m Jib				Unit: ton
		0	15	30	40	
10	25.3					
12	24.8					
14	22.4	15.7				
16	20.4	14.6				
18	18.6	13.6	10.8			
20	17.0	12.8	10.2	9.1		
22	15.6	12.0	9.8	8.8		
24	14.5	11.3	9.4	8.5		
26	13.4	10.7	9.0	8.2		
28	12.5	10.2	8.6	7.9		
30	11.7	9.7	8.3	7.5		
32	11.0	9.2	7.9	7.2		
34	10.4	8.8	7.5	7.0		
36	9.8	8.3	7.2	6.8		
38	9.2	7.8	6.9	6.6		
40	8.5	7.4	6.7	6.4		
42	7.9	7.0	6.5	6.4		
44	7.4	6.7	6.3			
46	6.9	6.4				
48	5.7	6.2				
50	4.5					
(°)	10 ~ 83	24 ~ 83	38 ~ 83	43 ~ 83		

D (°) B (m)		27.1m Jib				Unit: ton
		0	15	30	40	
12	10.0					
14	10.0					
16	10.0					
18	10.0	7.9				
20	10.0	7.4				
22	9.3	6.9				
24	8.5	6.4	5.1			
26	7.8	6.0	4.9	4.3		
28	7.3	5.7	4.7	4.2		
30	6.7	5.4	4.5	4.0		
32	6.3	5.1	4.3	3.9		
34	5.9	4.8	4.1	3.7		
36	5.5	4.6	3.9	3.6		
38	5.2	4.4	3.8	3.5		
40	4.9	4.2	3.7	3.4		
42	4.6	4.0	3.5	3.3		
44	4.4	3.8	3.4	3.3		
46	4.2	3.7	3.3	3.2		
48	3.9	3.5	3.3	3.2		
50	3.8	3.4	3.2	3.1		
52	3.6	3.3	3.2			
54	3.4	3.2	3.1			
56	3.3	3.1				
58	3.2					
(°)	11 ~ 83	26 ~ 83	35 ~ 83	46 ~ 83		

D (°) B (m)		35.1m Jib				Unit: ton
		0	15	30	40	
14	9.5					
16	8.6					
18	7.8					
20	7.1					
22	6.5	4.8				
24	6.0	4.5				
26	5.5	4.2				
28	5.1	3.9				
30	4.7	3.6	2.9			
32	4.4	3.4	2.8			
34	4.1	3.2	2.6	2.3		
36	3.8	3.0	2.5	2.2		
38	3.5	2.9	2.4	2.1		
40	3.3	2.7	2.3	2.0		
42	3.1	2.6	2.2	2.0		
44	2.9	2.4	2.1	1.9		
46	2.7	2.3	2.0	1.8		
48	2.6	2.2	1.9	1.8		
50	2.4	2.1	1.8	1.7		
52	2.3	2.0	1.8	1.7		
54	2.2	1.9	1.7	1.6		
56	2.1	1.8	1.7	1.6		
58	2.0	1.8	1.6	1.6		
60	1.8	1.7	1.6			
62	1.8	1.6	1.6			
64	1.7	1.6				
66	1.6					
(°)	13 ~ 83	31 ~ 83	38 ~ 83	48 ~ 83		

B= Working radius

D= Jib offset

= Boom angle range (for the unladen condition)

[41.8m Boom + 1.7m + Fully automatic luffing jib]
Performance A

Unit: ton				
11.1m Jib				
D (°) B (m)	0	15	30	40
	10	41.3		
12	41.3	35.8		
14	41.3	32.7	23.8	
16	37.8	30.2	22.5	19.5
18	33.5	27.9	21.3	18.7
20	29.8	26.0	20.2	18.0
22	26.6	24.3	19.3	17.3
24	23.7	22.2	18.4	16.7
26	21.2	20.2	17.7	16.2
28	19.0	18.5	17.0	15.7
30	17.1	16.9	16.3	15.3
32	15.4	15.3	15.1	14.9
34	13.9	13.9	13.9	13.9
36	12.3	12.6	12.6	12.7
38	10.4	11.2	11.4	11.4
40	8.4	9.4	9.8	9.9
42	6.6	7.4	7.8	
44	4.9	5.6	5.9	
46	3.5	4.0		
48	2.2	2.5		
(°)	20~83	21~83	36~83	44~83

Unit: ton				
19.1m Jib				
D (°) B (m)	0	15	30	40
	12	25.2		
14	24.7			
16	22.6	15.5		
18	20.9	14.5		
20	19.3	13.7	10.6	
22	17.8	12.9	10.2	9.0
24	16.5	12.2	9.8	8.7
26	15.4	11.6	9.4	8.4
28	14.4	11.1	9.1	8.2
30	13.5	10.5	8.8	8.0
32	12.7	10.1	8.5	7.7
34	12.0	9.7	8.2	7.5
36	11.3	9.3	7.9	7.2
38	10.8	8.9	7.6	7.0
40	9.9	8.6	7.3	6.8
42	9.0	8.2	7.1	6.7
44	8.1	7.8	6.8	6.5
46	6.6	7.5	6.6	6.4
48	5.2	6.4	6.5	6.3
50	4.0	4.9	5.6	
52	2.8	3.6	4.1	
54	1.8	2.4		
(°)	27~83	28~83	38~83	46~83

Unit: ton				
27.1m Jib				
D (°) B (m)	0	15	30	40
	12	10.0		
14	10.0			
16	10.0			
18	10.0			
20	10.0	7.7		
22	10.0	7.3		
24	9.5	6.8		
26	8.8	6.4	5.0	
28	8.2	6.1	4.8	
30	7.7	5.8	4.6	4.1
32	7.2	5.5	4.5	4.0
34	6.7	5.2	4.3	3.9
36	6.3	5.0	4.1	3.7
38	6.0	4.8	4.0	3.6
40	5.6	4.6	3.9	3.5
42	5.3	4.4	3.7	3.5
44	5.1	4.2	3.6	3.4
46	4.8	4.0	3.5	3.3
48	4.6	3.9	3.4	3.2
50	4.4	3.8	3.4	3.2
52	4.2	3.6	3.3	3.1
54	4.0	3.5	3.2	3.1
56	3.8	3.4	3.2	3.1
58	2.8	3.3	3.1	3.1
60	2.0	2.9	3.1	
62	1.2	1.9	2.3	
(°)	24~83	27~83	36~83	44~83

Unit: ton				
35.1m Jib				
D (°) B (m)	0	15	30	40
	16	9.4		
18	8.5			
20	7.8			
22	7.2			
24	6.6	4.7		
26	6.2	4.4		
28	5.7	4.1		
30	5.3	3.9		
32	4.9	3.7	2.9	
34	4.6	3.5	2.7	
36	4.3	3.3	2.6	2.3
38	4.0	3.1	2.5	2.2
40	3.8	3.0	2.4	2.1
42	3.6	2.8	2.3	2.0
44	3.4	2.7	2.2	2.0
46	3.2	2.6	2.1	1.9
48	3.0	2.4	2.0	1.8
50	2.8	2.3	2.0	1.8
52	2.7	2.2	1.9	1.7
54	2.5	2.1	1.8	1.7
56	2.4	2.0	1.8	1.6
58	2.3	2.0	1.7	1.6
60	2.2	1.9	1.7	1.6
62	2.1	1.8	1.6	1.6
64	2.0	1.7	1.6	1.5
66	1.8	1.7	1.6	1.5
68	1.1	1.6	1.5	
70	1.3	1.5		
(°)	28~83	32~83	39~83	48~83

B= Working radius

D= Jib offset

= Boom angle range (for the unladen condition)

[51.0m Boom + 1.7m + Fully automatic luffing jib]
Performance A

D (°) B (m)		11.1m Jib				Unit: ton
		0	15	30	40	
10	26.4					
12	26.4					
14	26.4	21.2				
16	23.5	19.1	16.3			
18	20.9	17.2	15.0	13.9		
20	18.6	15.7	13.8	12.9		
22	16.7	14.3	12.7	11.9		
24	15.1	13.1	11.6	11.0		
26	13.7	11.9	10.7	10.2		
28	12.4	10.9	9.9	9.5		
30	11.3	10.0	9.1	8.8		
32	10.2	9.1	8.4	8.2		
34	9.3	8.4	7.8	7.6		
36	8.5	7.7	7.2	7.1		
38	7.7	7.1	6.7	6.6		
40	6.9	6.5	6.2	6.1		
42	6.0	6.0	5.7	5.7		
44	5.2	5.3	5.3	5.3		
46	4.4	4.6	4.6	4.6		
48	3.1	3.8	4.0			
50	1.8	2.4	2.8			
(°)	36~83	37~83	37~83	46~83		

D (°) B (m)		19.1m Jib				Unit: ton
		0	15	30	40	
14	18.0					
16	17.7					
18	15.7	12.1				
20	14.0	11.0				
22	12.5	10.0	8.4			
24	11.2	9.1	7.8	7.1		
26	10.1	8.4	7.2	6.7		
28	9.2	7.7	6.7	6.2		
30	8.3	7.0	6.2	5.9		
32	7.5	6.5	5.8	5.5		
34	6.9	6.0	5.4	5.1		
36	6.3	5.5	5.0	4.7		
38	5.7	5.1	4.6	4.4		
40	5.2	4.7	4.2	4.1		
42	4.8	4.3	3.9	3.8		
44	4.3	3.9	3.6	3.5		
46	3.9	3.5	3.3	3.2		
48	3.6	3.2	3.0	2.9		
50	3.2	2.9	2.7	2.6		
52	2.8	2.5	2.4	2.3		
54	2.2	2.2	2.1	2.1		
56		2.0	1.9	1.9		
(°)	40~83	41~83	42~83	45~83		

D (°) B (m)		27.1m Jib				Unit: ton
		0	15	30	40	
16	10.0					
18	10.0					
20	10.0					
22	10.0	7.6				
24	9.6	7.2				
26	8.7	6.8				
28	7.9	6.4	5.0			
30	7.1	5.9	4.8			
32	6.5	5.5	4.6	4.1		
34	5.9	5.0	4.4	3.9		
36	5.4	4.7	4.1	3.8		
38	4.9	4.3	3.9	3.7		
40	4.5	4.0	3.6	3.5		
42	4.1	3.7	3.4	3.3		
44	3.8	3.4	3.2	3.0		
46	3.5	3.2	3.0	2.8		
48	3.2	2.9	2.7	2.6		
50	2.9	2.7	2.5	2.4		
52	2.7	2.5	2.3	2.3		
54	2.4	2.3	2.1	2.1		
56	2.2	2.1	2.0	1.9		
58	2.0	1.9	1.8	1.7		
60	1.8	1.7	1.6	1.5		
62	1.4	1.4	1.4	1.4		
64		1.2	1.2	1.2		
66			1.0			
(°)	38~83	41~83	41~83	47~83		

D (°) B (m)		35.1m Jib				Unit: ton
		0	15	30	40	
18	8.0					
20	8.0					
22	7.8					
24	7.2					
26	6.7	4.6				
28	6.3	4.3				
30	5.8	4.1				
32	5.5	3.9				
34	5.1	3.7	2.8			
36	4.8	3.5	2.7			
38	4.4	3.3	2.6	2.2		
40	4.0	3.2	2.5	2.2		
42	3.7	3.0	2.4	2.1		
44	3.3	2.9	2.3	2.0		
46	3.1	2.7	2.2	2.0		
48	2.8	2.5	2.1	1.9		
50	2.6	2.3	2.1	1.8		
52	2.3	2.1	2.0	1.8		
54	2.1	2.0	1.9	1.7		
56	1.9	1.8	1.8	1.7		
58	1.8	1.7	1.6	1.6		
60	1.6	1.5	1.5	1.5		
62	1.4	1.4	1.3	1.3		
64	1.3	1.2	1.2	1.1		
66	1.1	1.0	1.0	1.0		
(°)	43~83	49~83	53~83	54~83		

B= Working radius

D= Jib offset

= Boom angle range (for the unladen condition)

[14.2m Boom + 1.7m + Fully automatic luffing jib]
Performance B

11.1m Jib					Unit: ton		
D (°)	B (m)	0	15	30	40		
		5	54.0	41.3			
6	54.0	37.3					
7	47.3	34.0	26.6				
8	41.9	31.2	24.9				
9	37.6	28.8	23.4	21.0			
10	34.0	26.7	22.1	19.9			
12	28.4	23.2	19.8	18.2			
14	24.2	20.5	18.0	16.8			
16	21.0	18.3	16.5	15.6			
18	18.5	16.6	15.3	14.8			
20	16.4	15.1	14.3	14.2			
22	14.6	13.9					
24	13.2						
(°)	0 ~ 83	28 ~ 83	33 ~ 83	42 ~ 83			

19.1m Jib					Unit: ton		
D (°)	B (m)	0	15	30	40		
		8	25.5				
9	23.6	18.0					
10	21.9	16.9					
12	19.0	15.0					
14	16.6	13.5	11.3				
16	14.7	12.2	10.4	9.5			
18	13.2	11.2	9.7	8.9			
20	11.9	10.2	8.9	8.3			
22	10.5	9.2	8.2	7.7			
24	9.4	8.4	7.6	7.2			
26	8.4	7.6	7.0	6.8			
28	7.5	7.0	6.6	6.5			
30	6.8	6.5					
32	6.1						
(°)	0 ~ 83	29 ~ 83	42 ~ 83	43 ~ 83			

27.1m Jib					Unit: ton		
D (°)	B (m)	0	15	30	40		
		8	10.0				
9	10.0						
10	10.0						
12	10.0	9.5					
14	10.0	8.5					
16	9.4	7.6					
18	8.3	6.9	5.8				
20	7.4	6.3	5.4				
22	6.7	5.7	5.0	4.6			
24	6.1	5.3	4.6	4.3			
26	5.6	4.9	4.3	4.0			
28	5.1	4.5	4.1	3.8			
30	4.7	4.2	3.8	3.6			
32	4.3	4.0	3.6	3.5			
34	4.0	3.7	3.5	3.3			
36	3.8	3.5	3.3	3.3			
38	3.5	3.4	3.3				
40	3.3						
(°)	0 ~ 83	31 ~ 83	36 ~ 83	47 ~ 83			

35.1m Jib					Unit: ton		
D (°)	B (m)	0	15	30	40		
		10	9.5				
12	9.2						
14	8.0						
16	7.0	5.7					
18	6.3	5.1					
20	5.6	4.6					
22	5.0	4.2					
24	4.5	3.9	3.3				
26	4.1	3.5	3.1				
28	3.7	3.3	2.8	2.6			
30	3.4	3.0	2.6	2.4			
32	3.1	2.8	2.5	2.3			
34	2.9	2.6	2.3	2.1			
36	2.7	2.4	2.2	2.0			
38	2.5	2.2	2.0	1.9			
40	2.3	2.1	1.9	1.8			
42	2.1	1.9	1.8	1.7			
44	1.9	1.8	1.7	1.7			
46	1.8	1.7	1.7				
48	1.7						
(°)	0 ~ 83	33 ~ 83	41 ~ 83	51 ~ 83			

B= Working radius

D= Jib offset

= Boom angle range (for the unladen condition)

[23.4m Boom + 1.7m + Fully automatic luffing jib]
Performance B

D (°) B (m)		11.1m Jib				Unit: ton
		0	15	30	40	
6	54.0					
7	54.0	39.4				
8	54.0	36.6				
9	52.1	34.2	25.6			
10	47.3	32.0	24.4			
12	39.7	28.4	22.3	19.8		
14	34.0	25.5	20.6	18.5		
16	29.7	23.1	19.1	17.4		
18	26.2	21.0	17.9	16.5		
20	23.4	19.3	16.8	15.7		
22	21.1	17.9	15.9	15.1		
24	19.1	16.6	15.1	14.6		
26	17.4	15.5	14.4	14.2		
28	16.0	14.6	13.9			
30	14.7	13.8				
32	13.4	13.2				
(°)	16~83	18~83	38~83	45~83		

D (°) B (m)		19.1m Jib				Unit: ton
		0	15	30	40	
8	29.0					
9	27.2					
10	25.5					
12	22.6	16.4				
14	20.2	14.9				
16	18.0	13.7	11.1			
18	16.2	12.7	10.4	9.3		
20	14.7	11.8	9.8	8.9		
22	13.5	11.0	9.3	8.5		
24	12.4	10.3	8.8	8.0		
26	11.5	9.7	8.3	7.6		
28	10.6	9.0	7.8	7.2		
30	9.7	8.3	7.3	6.9		
32	8.9	7.7	7.0	6.7		
34	8.1	7.2	6.7	6.5		
36	7.5	6.8	6.4			
38	6.9	6.4				
40	6.4	6.1				
(°)	16~83	20~83	39~83	46~83		

D (°) B (m)		27.1m Jib				Unit: ton
		0	15	30	40	
8	10.0					
9	10.0					
10	10.0					
12	10.0					
14	10.0					
16	10.0	8.2				
18	9.8	7.5				
20	8.9	6.9	5.6			
22	8.1	6.4	5.2			
24	7.4	5.9	4.9	4.4		
26	6.8	5.5	4.7	4.2		
28	6.2	5.2	4.4	4.0		
30	5.8	4.9	4.2	3.9		
32	5.4	4.6	4.0	3.7		
34	5.0	4.3	3.8	3.6		
36	4.7	4.1	3.7	3.5		
38	4.4	3.9	3.5	3.4		
40	4.1	3.7	3.4	3.3		
42	3.9	3.5	3.3	3.2		
44	3.7	3.4	3.2			
46	3.5	3.3	3.2			
48	3.3	3.2				
(°)	16~83	23~83	35~83	49~83		

D (°) B (m)		35.1m Jib				Unit: ton
		0	15	30	40	
10	9.5					
12	9.5					
14	8.8					
16	7.8					
18	7.0					
20	6.4	4.9				
22	5.8	4.5				
24	5.3	4.2				
26	4.8	3.9				
28	4.4	3.6	3.0			
30	4.1	3.4	2.8			
32	3.8	3.1	2.6	2.4		
34	3.5	2.9	2.5	2.2		
36	3.2	2.7	2.4	2.1		
38	3.0	2.6	2.2	2.0		
40	2.8	2.4	2.1	1.9		
42	2.6	2.3	2.0	1.9		
44	2.5	2.2	1.9	1.8		
46	2.3	2.0	1.8	1.7		
48	2.2	1.9	1.8	1.7		
50	2.0	1.8	1.7	1.6		
52	1.9	1.8	1.6	1.6		
54	1.8	1.7	1.6			
56	1.7	1.6				
(°)	17~83	26~83	38~83	46~83		

B= Working radius

D= Jib offset

= Boom angle range (for the unladen condition)

[32.6m Boom + 1.7m + Fully automatic luffing jib]
Performance B

11.1m Jib					Unit: ton		
D (°)	B (m)	0	15	30	40		
		9	54.0	38.2			
10	54.0	36.1					
12	51.0	32.5	24.0				
14	43.9	29.5	22.4	19.6			
16	38.4	26.9	21.0	18.7			
18	34.0	24.8	19.8	17.8			
20	30.5	22.9	18.7	17.0			
22	27.5	21.3	17.8	16.3			
24	24.3	19.9	16.9	15.7			
26	20.3	18.7	16.2	15.2			
28	17.0	17.6	15.5	14.8			
30	14.2	15.3	14.9	14.4			
32	11.5	12.7	13.4	13.6			
34	9.0	10.1	10.7				
36	6.8	7.6	8.0				
38	4.8	5.5					
40	3.1	3.5					
42	1.6						
(°)	11~83	23~83	37~83	47~83			

19.1m Jib					Unit: ton		
D (°)	B (m)	0	15	30	40		
		10	25.3				
12	24.8						
14	22.4	15.7					
16	20.4	14.6					
18	18.6	13.6	10.8				
20	17.0	12.8	10.2	9.1			
22	15.6	12.0	9.8	8.8			
24	14.5	11.3	9.4	8.5			
26	13.4	10.7	9.0	8.2			
28	12.5	10.2	8.6	7.9			
30	11.7	9.7	8.3	7.5			
32	11.0	9.2	7.9	7.2			
34	10.4	8.8	7.5	7.0			
36	9.8	8.2	7.2	6.8			
38	8.6	7.8	6.9	6.6			
40	6.8	7.4	6.7	6.4			
42	5.2	6.5	6.5	6.4			
44	3.8	4.8	5.4				
46	2.5	3.3					
48	1.4	1.9					
(°)	22~83	24~83	38~83	43~83			

27.1m Jib					Unit: ton		
D (°)	B (m)	0	15	30	40		
		12	10.0				
14	10.0						
16	10.0						
18	10.0	7.9					
20	10.0	7.4					
22	9.3	6.9					
24	8.5	6.4	5.1				
26	7.8	6.0	4.9	4.3			
28	7.3	5.7	4.7	4.2			
30	6.7	5.4	4.4	4.0			
32	6.3	5.1	4.3	3.9			
34	5.9	4.8	4.1	3.7			
36	5.5	4.6	3.9	3.6			
38	5.2	4.4	3.8	3.5			
40	4.9	4.2	3.7	3.4			
42	4.6	4.0	3.5	3.3			
44	4.4	3.8	3.4	3.3			
46	4.2	3.7	3.3	3.2			
48	3.9	3.5	3.3	3.2			
50	3.6	3.4	3.2	3.1			
52	2.6	3.3	3.1				
54	1.7	2.5	2.9				
(°)	21~83	22~83	35~83	46~83			

35.1m Jib					Unit: ton		
D (°)	B (m)	0	15	30	40		
		14	9.5				
16	8.6						
18	7.8						
20	7.1						
22	6.5	4.8					
24	6.0	4.5					
26	5.5	4.2					
28	5.1	3.9					
30	4.7	3.6	2.9				
32	4.4	3.4	2.8				
34	4.1	3.2	2.6	2.3			
36	3.8	3.0	2.5	2.2			
38	3.5	2.9	2.4	2.1			
40	3.3	2.7	2.3	2.0			
42	3.1	2.6	2.2	2.0			
44	2.9	2.4	2.1	1.9			
46	2.7	2.3	2.0	1.8			
48	2.6	2.2	1.9	1.8			
50	2.4	2.1	1.8	1.7			
52	2.3	2.0	1.8	1.7			
54	2.2	1.9	1.7	1.6			
56	2.1	1.8	1.7	1.6			
58	2.0	1.8	1.6	1.6			
60	1.6	1.7	1.6				
62		1.6	1.6				
(°)	27~83	32~83	38~83	48~83			

B= Working radius

D= Jib offset

= Boom angle range (for the unladen condition)

[41.8m Boom + 1.7m + Fully automatic luffing jib]
Performance B

D (°) B (m)		11.1m Jib				Unit: ton
		0	15	30	40	
10	41.3					
12	41.3	35.8				
14	41.3	32.7	23.8			
16	37.8	30.2	22.5	19.5		
18	33.5	27.9	21.3	18.7		
20	29.8	26.0	20.2	18.0		
22	26.6	24.3	19.3	17.3		
24	23.7	22.2	18.4	16.7		
26	20.4	20.2	17.7	16.2		
28	17.1	18.5	17.0	15.7		
30	14.3	15.6	16.3	15.3		
32	11.6	13.0	14.0	14.4		
34	9.0	10.5	11.5	11.9		
36	6.8	8.1	9.0	9.3		
38	4.8	5.9	6.7	6.9		
40	3.1	4.0	4.6	4.7		
42	1.5	2.3	2.8			
(°)	37~83	39~83	40~83	44~83		

D (°) B (m)		19.1m Jib				Unit: ton
		0	15	30	40	
12	25.2					
14	24.7					
16	22.6	15.5				
18	20.9	14.5				
20	19.3	13.7	10.6			
22	17.8	12.9	10.2	9.0		
24	16.5	12.2	9.8	8.7		
26	15.4	11.6	9.4	8.4		
28	14.4	11.1	9.1	8.2		
30	13.5	10.5	8.8	8.0		
32	12.7	10.1	8.5	7.7		
34	12.0	9.7	8.2	7.5		
36	10.2	8.3	7.9	7.2		
38	8.2	8.9	7.6	7.0		
40	6.4	8.2	7.3	6.8		
42	4.8	6.4	7.1	6.7		
44	3.3	4.8	5.9	6.4		
46	2.0	3.3	4.3	4.6		
48		2.0	2.8	3.0		
(°)	42~83	43~83	45~83	46~83		

D (°) B (m)		27.1m Jib				Unit: ton
		0	15	30	40	
12	10.0					
14	10.0					
16	10.0					
18	10.0					
20	10.0	7.7				
22	10.0	7.3				
24	9.5	6.8				
26	8.8	6.4	5.0			
28	8.2	6.1	4.8			
30	7.7	5.8	4.6	4.1		
32	7.2	5.5	4.5	4.0		
34	6.7	5.2	4.3	3.9		
36	6.3	5.0	4.1	3.7		
38	6.0	4.8	4.0	3.6		
40	5.6	4.6	3.9	3.5		
42	5.3	4.4	3.7	3.5		
44	5.1	4.2	3.6	3.4		
46	4.8	4.0	3.5	3.3		
48	4.0	3.9	3.4	3.2		
50	2.9	3.8	3.4	3.2		
52	1.9	3.4	3.3	3.1		
54		2.3	3.2	3.1		
56		1.3	2.2	2.5		
58			1.1	1.2		
(°)	40~83	43~83	44~83	44~83		

D (°) B (m)		35.1m Jib				Unit: ton
		0	15	30	40	
16	9.4					
18	8.5					
20	7.8					
22	7.2					
24	6.6	4.7				
26	6.2	4.4				
28	5.7	4.1				
30	5.3	3.9				
32	4.9	3.7	2.9			
34	4.6	3.5	2.7			
36	4.3	3.3	2.6	2.3		
38	4.0	3.1	2.5	2.2		
40	3.8	3.0	2.4	2.1		
42	3.6	2.8	2.3	2.0		
44	3.4	2.7	2.2	2.0		
46	3.2	2.6	2.1	1.9		
48	3.0	2.4	2.0	1.8		
50	2.8	2.3	2.0	1.8		
52	2.7	2.2	1.9	1.7		
54	2.5	2.1	1.8	1.7		
56	2.2	2.0	1.8	1.6		
58	1.4	2.0	1.7	1.6		
60		1.9	1.7	1.6		
62		1.3	1.6	1.6		
64			1.5	1.5		
(°)	44~83	46~83	48~83	51~83		

B= Working radius

D= Jib offset

= Boom angle range (for the unladen condition)

[51.0m Boom + 1.7m + Fully automatic luffing jib]
Performance B

11.1m Jib					Unit: ton						
D (°)	B (m)	0	15	30	40	D (°)	B (m)	0	15	30	40
		10	26.4							14	18.0
12	26.4	21.2				16	17.7				
14	26.4					18	15.7	12.1			
16	23.5	19.1	16.3			20	14.0	11.0			
18	20.9	17.2	15.0	13.9		22	12.5	10.0	8.4		
20	18.6	15.7	13.8	12.9		24	11.2	9.1	7.8	7.1	
22	16.7	14.3	12.7	11.9		26	10.1	8.4	7.2	6.7	
24	15.1	13.1	11.6	11.0		28	9.2	7.7	6.7	6.2	
26	13.7	11.9	10.7	10.2		30	8.3	7.0	6.2	5.9	
28	12.4	10.9	9.9	9.5		32	7.5	6.5	5.8	5.5	
30	11.3	10.0	9.1	8.8		34	6.9	6.0	5.4	5.1	
32	10.2	9.1	8.4	8.2		36	6.3	5.5	5.0	4.7	
34	9.3	8.4	7.8	7.6		38	5.7	5.1	4.6	4.4	
36	7.8	7.7	7.2	7.1		40	5.2	4.7	4.2	4.0	
38	5.9	7.1	6.7	6.6		42	4.8	4.3	3.9	3.8	
40	4.1	5.2	6.1	6.1		44	3.9	3.9	3.6	3.5	
42		3.5	4.3	4.5		46		3.5	3.3	3.2	
44			2.6	2.8		48			3.0	2.9	
(°)	50~83	50~83	49~83	49~83		(°)	52~83	54~83	54~83	55~83	

19.1m Jib					Unit: ton						
D (°)	B (m)	0	15	30	40	D (°)	B (m)	0	15	30	40
		14	18.0							16	10.0
16	17.7					18	10.0				
18	15.7	12.1				20	10.0				
20	14.0	11.0				22	10.0	7.6			
22	12.5	10.0	8.4			24	9.6	7.2			
24	11.2	9.1	7.8	7.1		26	8.7	6.8			
26	10.1	8.4	7.2	6.7		28	7.9	6.4	5.0		
28	9.2	7.7	6.7	6.2		30	7.1	5.9	4.8		
30	8.3	7.0	6.2	5.9		32	6.5	5.5	4.6	4.1	
32	7.5	6.5	5.8	5.5		34	5.9	5.0	4.4	3.9	
34	6.9	6.0	5.4	5.1		36	5.4	4.7	4.1	3.8	
36	6.3	5.5	5.0	4.7		38	4.9	4.3	3.9	3.7	
38	5.7	5.1	4.6	4.4		40	4.5	4.0	3.6	3.5	
40	5.2	4.7	4.2	4.0		42	4.1	3.7	3.4	3.3	
42	4.8	4.3	3.9	3.8		44	3.8	3.4	3.2	3.0	
44	3.9	3.9	3.6	3.5		46	3.5	3.1	3.0	2.8	
46		3.5	3.3	3.2		48	3.2	2.9	2.7	2.6	
48			3.0	2.9		50	2.9	2.7	2.5	2.4	
(°)	52~83	54~83	54~83	55~83		52	2.1	2.5	2.3	2.3	
						54		2.3	2.1	2.1	
						56		1.8	1.8	1.7	
						58					
						58			1.8	1.8	1.7
(°)	50~83	54~83	54~83	55~83		(°)	50~83	52~83	53~83	54~83	

27.1m Jib					Unit: ton						
D (°)	B (m)	0	15	30	40	D (°)	B (m)	0	15	30	40
		16	10.0							16	10.0
18	10.0					18	10.0				
20	10.0					20	10.0				
22	10.0	7.6				22	10.0	7.6			
24	9.6	7.2				24	9.6	7.2			
26	8.7	6.8				26	8.7	6.8			
28	7.9	6.4	5.0			28	7.9	6.4	5.0		
30	7.1	5.9	4.8			30	7.1	5.9	4.8		
32	6.5	5.5	4.6	4.1		32	6.5	5.5	4.6	4.1	
34	5.9	5.0	4.4	3.9		34	5.9	5.0	4.4	3.9	
36	5.4	4.7	4.1	3.8		36	5.4	4.7	4.1	3.8	
38	4.9	4.3	3.9	3.7		38	4.9	4.3	3.9	3.7	
40	4.5	4.0	3.6	3.5		40	4.5	4.0	3.6	3.5	
42	4.1	3.7	3.4	3.3		42	4.1	3.7	3.4	3.3	
44	3.8	3.4	3.2	3.0		44	3.8	3.4	3.2	3.0	
46	3.5	3.1	3.0	2.8		46	3.5	3.1	3.0	2.8	
48	3.2	2.9	2.7	2.6		48	3.2	2.9	2.7	2.6	
50	2.9	2.7	2.5	2.4		50	2.9	2.7	2.5	2.4	
52	2.1	2.5	2.3	2.3		52	2.1	2.5	2.3	2.3	
54		2.3	2.1	2.1		54		2.3	2.1	2.1	
56		1.8	1.8	1.7		56		1.8	1.8	1.7	
58						58					
58			1.8	1.7		58			1.8	1.7	
(°)	50~83	52~83	53~83	54~83		(°)	50~83	52~83	53~83	54~83	

35.1m Jib					Unit: ton						
D (°)	B (m)	0	15	30	40	D (°)	B (m)	0	15	30	40
		18	8.0							18	8.0
20	8.0					20	8.0				
22	7.8					22	7.8				
24	7.2					24	7.2				
26	6.7	4.6				26	6.7	4.6			
28	6.3	4.3				28	6.3	4.3			
30	5.8	4.1				30	5.8	4.1			
32	5.5	3.9				32	5.5	3.9			
34	5.1	3.7	2.8			34	5.1	3.7	2.8		
36	4.8	3.5	2.7			36	4.8	3.5	2.7		
38	4.4	3.3	2.6	2.2		38	4.4	3.3	2.6	2.2	
40	4.0	3.2	2.5	2.2		40	4.0	3.2	2.5	2.2	
42	3.7	3.0	2.4	2.1		42	3.7	3.0	2.4	2.1	
44	3.3	2.9	2.3	2.0		44	3.3	2.9	2.3	2.0	
46	3.1	2.7	2.2	2.0		46	3.1	2.7	2.2	2.0	
48	2.8	2.5	2.1	1.9		48	2.8	2.5	2.1	1.9	
50	2.6	2.3	2.1	1.8		50	2.6	2.3	2.1	1.8	
52	2.3	2.1	2.0	1.8		52	2.3	2.1	2.0	1.8	
54	2.1	2.0	1.9	1.7		54	2.1	2.0	1.9	1.7	
56	1.9	1.8	1.8	1.7		56	1.9	1.8	1.8	1.7	
58		1.7	1.6	1.6		58		1.7	1.6	1.6	
60		1.5	1.5	1.5		60		1.5	1.5	1.5	
62			1.3	1.3		62			1.3	1.3	
64			1.2	1.1		64			1.2	1.1	
66				1.0		66				1.0	
(°)	53~83	55~83	56~83	56~83		(°)	53~83	55~83	56~83	56~83	

B= Working radius

D= Jib offset

= Boom angle range (for the unladen condition)

[14.2m Boom + 1.7m + Fully automatic luffing jib]
Performance C

D (°) B (m)		11.1m Jib				Unit: ton
		0	15	30	40	
5	54.0	41.3				
6	54.0	37.3				
7	47.3	34.0	26.6			
8	41.9	31.2	24.9			
9	37.6	28.8	23.4	21.0		
10	34.0	26.7	22.1	19.9		
12	28.4	23.2	19.8	18.2		
14	24.2	20.5	18.0	16.8		
16	21.0	18.3	16.5	15.6		
18	18.5	16.6	15.3	14.8		
20	16.4	15.1	14.3	14.2		
22	14.6	13.9				
24	13.2					
(°)	0 ~ 83	28 ~ 83	33 ~ 83	42 ~ 83		

D (°) B (m)		19.1m Jib				Unit: ton
		0	15	30	40	
8	25.5					
9	23.6	18.0				
10	21.9	16.9				
12	19.0	15.0				
14	16.6	13.5	11.3			
16	14.7	12.2	10.4	9.5		
18	13.2	11.2	9.7	8.9		
20	11.9	10.2	8.9	8.3		
22	10.5	9.2	8.2	7.7		
24	9.4	8.4	7.6	7.2		
26	8.4	7.6	7.0	6.8		
28	7.5	7.0	6.6	6.5		
30	6.8	6.5				
32	6.1					
(°)	0 ~ 83	29 ~ 83	42 ~ 83	43 ~ 83		

D (°) B (m)		27.1m Jib				Unit: ton
		0	15	30	40	
8	10.0					
9	10.0					
10	10.0					
12	10.0	9.5				
14	10.0	8.5				
16	9.4	7.6				
18	8.3	6.9	5.8			
20	7.4	6.3	5.4			
22	6.7	5.7	5.0	4.6		
24	6.1	5.3	4.6	4.3		
26	5.6	4.9	4.3	4.0		
28	5.1	4.5	4.1	3.8		
30	4.7	4.2	3.8	3.6		
32	4.3	4.0	3.6	3.5		
34	4.0	3.7	3.5	3.3		
36	3.8	3.5	3.3	3.3		
38	3.5	3.4	3.3			
40	3.3					
(°)	0 ~ 83	31 ~ 83	36 ~ 83	47 ~ 83		

D (°) B (m)		35.1m Jib				Unit: ton
		0	15	30	40	
10	9.5					
12	9.2					
14	8.0					
16	7.0	5.7				
18	6.3	5.1				
20	5.6	4.6				
22	5.0	4.2				
24	4.5	3.9	3.3			
26	4.1	3.5	3.1			
28	3.7	3.3	2.8	2.6		
30	3.4	3.0	2.6	2.4		
32	3.1	2.8	2.5	2.3		
34	2.9	2.6	2.3	2.1		
36	2.7	2.4	2.2	2.0		
38	2.5	2.2	2.0	1.9		
40	2.3	2.1	1.9	1.8		
42	2.1	1.9	1.8	1.7		
44	1.9	1.8	1.7	1.7		
46	1.8	1.7	1.7			
48	1.7					
(°)	0 ~ 83	33 ~ 83	41 ~ 83	51 ~ 83		

B= Working radius

D= Jib offset

= Boom angle range (for the unladen condition)

[23.4m Boom + 1.7m + Fully automatic luffing jib]
Performance C

11.1m Jib					Unit: ton
D (°)	B (m)	0	15	30	40
		6	54.0		
7	54.0	39.4			
8	54.0	36.6			
9	52.1	34.2	25.6		
10	47.3	32.0	24.4		
12	39.7	28.4	22.3	19.8	
14	34.0	25.5	20.6	18.5	
16	29.7	23.1	19.1	17.4	
18	26.2	21.0	17.9	16.5	
20	23.4	19.3	16.8	15.7	
22	21.1	17.9	15.9	15.1	
24	18.7	16.6	15.1	14.6	
26	15.2	15.5	14.4	14.2	
28	12.2	13.1	13.6		
30	9.8	10.4			
32	7.4	7.8			
(°)	16~83	18~83	38~83	45~83	

19.1m Jib					Unit: ton
D (°)	B (m)	0	15	30	40
		8	29.0		
9	27.2				
10	25.5				
12	22.6	16.4			
14	20.2	14.9			
16	18.0	13.7	11.1		
18	16.2	12.7	10.4	9.3	
20	14.7	11.8	9.8	8.9	
22	13.5	11.0	9.3	8.5	
24	12.4	10.3	8.8	8.0	
26	11.5	9.7	8.3	7.6	
28	10.6	9.0	7.8	7.2	
30	9.7	8.3	7.3	6.9	
32	8.9	7.7	7.0	6.7	
34	8.1	7.2	6.7	6.5	
36	7.5	6.8	6.4		
38	5.9	6.4			
40	4.4	4.8			
(°)	16~83	20~83	39~83	46~83	

27.1m Jib					Unit: ton
D (°)	B (m)	0	15	30	40
		8	10.0		
9	10.0				
10	10.0				
12	10.0				
14	10.0				
16	10.0	8.2			
18	9.8	7.5			
20	8.9	6.9	5.6		
22	8.1	6.4	5.2		
24	7.4	5.9	4.9	4.4	
26	6.8	5.5	4.7	4.2	
28	6.2	5.2	4.4	4.0	
30	5.8	4.9	4.2	3.9	
32	5.4	4.6	4.0	3.7	
34	5.0	4.3	3.8	3.6	
36	4.7	4.1	3.7	3.5	
38	4.4	3.9	3.5	3.4	
40	4.1	3.7	3.4	3.3	
42	3.9	3.5	3.3	3.2	
44	3.7	3.4	3.2		
46	3.5	3.3	3.2		
48	3.2	3.2			
(°)	16~83	23~83	35~83	49~83	

35.1m Jib					Unit: ton
D (°)	B (m)	0	15	30	40
		10	9.5		
12	9.5				
14	8.8				
16	7.8				
18	7.0				
20	6.4	4.9			
22	5.8	4.5			
24	5.3	4.2			
26	4.8	3.9			
28	4.4	3.6	3.0		
30	4.1	3.4	2.8		
32	3.8	3.1	2.6	2.4	
34	3.5	2.9	2.5	2.2	
36	3.2	2.7	2.4	2.1	
38	3.0	2.6	2.2	2.0	
40	2.8	2.4	2.1	1.9	
42	2.6	2.3	2.0	1.9	
44	2.5	2.2	1.9	1.8	
46	2.3	2.0	1.8	1.7	
48	2.2	1.9	1.8	1.7	
50	2.0	1.8	1.7	1.6	
52	1.9	1.8	1.6	1.6	
54	1.8	1.7	1.6		
56	1.7	1.6			
(°)	17~83	26~83	38~83	46~83	

B= Working radius

D= Jib offset

= Boom angle range (for the unladen condition)

[32.6m Boom + 1.7m + Fully automatic luffing jib]
Performance C

D (°) B (m)		11.1m Jib				Unit: ton
		0	15	30	40	
9	54.0	38.2				
10	54.0	36.1				
12	51.0	32.5	24.0			
14	43.9	29.5	22.4	19.6		
16	38.4	26.9	21.0	18.7		
18	33.5	24.8	19.8	17.8		
20	26.7	22.9	18.7	17.0		
22	21.3	21.3	17.8	16.3		
24	17.0	18.9	16.9	15.7		
26	13.5	15.1	16.2	15.2		
28	10.5	12.0	13.1	13.6		
30	7.7	9.2	10.2	10.5		
32	5.2	6.5	7.4	7.7		
34	3.1	4.2	4.8			
36		2.1	2.5			
(°)	34~83	35~83	37~83	47~83		

D (°) B (m)		19.1m Jib				Unit: ton
		0	15	30	40	
10	25.3					
12	24.8					
14	22.4	15.7				
16	20.4	14.6				
18	18.6	13.6	10.8			
20	17.0	12.8	10.2	9.1		
22	15.6	12.0	9.8	8.8		
24	14.5	11.3	9.4	8.5		
26	13.4	10.7	9.0	8.2		
28	12.5	10.2	8.6	7.9		
30	11.3	9.7	8.3	7.5		
32	9.2	9.2	7.9	7.2		
34	7.0	8.8	7.5	7.0		
36	5.1	7.0	7.2	6.8		
38	3.4	5.1	6.4	6.6		
40	1.9	3.4	4.4	4.8		
42		1.8	2.6	2.8		
(°)	39~83	40~83	43~83	43~83		

D (°) B (m)		27.1m Jib				Unit: ton
		0	15	30	40	
12	10.0					
14	10.0					
16	10.0					
18	10.0	7.9				
20	10.0	7.4				
22	9.3	6.9				
24	8.5	6.4	5.1			
26	7.8	6.0	4.9	4.3		
28	7.3	5.7	4.7	4.2		
30	6.7	5.4	4.4	4.0		
32	6.3	5.1	4.3	3.9		
34	5.9	4.8	4.1	3.7		
36	5.5	4.6	3.9	3.6		
38	5.2	4.4	3.8	3.5		
40	4.9	4.2	3.7	3.4		
42	4.1	4.0	3.5	3.3		
44	2.9	3.8	3.4	3.3		
46	1.7	3.4	3.3	3.2		
48		2.2	3.3	3.2		
50		1.1	2.0	2.3		
(°)	38~83	40~83	44~83	46~83		

D (°) B (m)		35.1m Jib				Unit: ton
		0	15	30	40	
14	9.5					
16	8.6					
18	7.8					
20	7.1					
22	6.5	4.8				
24	6.0	4.5				
26	5.5	4.2				
28	5.1	3.9				
30	4.7	3.6	2.9			
32	4.4	3.4	2.8			
34	4.1	3.2	2.6	2.3		
36	3.8	3.0	2.5	2.2		
38	3.5	2.9	2.4	2.1		
40	3.3	2.7	2.3	2.0		
42	3.1	2.6	2.2	2.0		
44	2.9	2.4	2.1	1.9		
46	2.7	2.3	2.0	1.8		
48	2.6	2.2	1.9	1.8		
50	2.1	2.1	1.8	1.7		
52	1.3	2.0	1.8	1.7		
54		1.9	1.7	1.6		
56		1.2	1.7	1.6		
58			1.3	1.6		
(°)	42~83	45~83	46~83	48~83		

B= Working radius

D= Jib offset

= Boom angle range (for the unladen condition)

[41.8m Boom + 1.7m + Fully automatic luffing jib]
Performance C

Unit: ton				
11.1m Jib				
D (°) B (m)	0	15	30	40
	10	41.3		
12	41.3	35.8		
14	41.3	32.7	23.8	
16	37.8	30.2	22.5	19.5
18	33.5	27.9	21.3	18.7
20	26.8	26.0	20.2	18.0
22	21.4	23.8	19.3	17.3
24	17.1	19.2	18.4	16.7
26	13.6	15.4	16.9	16.2
28	10.6	12.3	13.6	14.2
30	7.8	9.6	10.8	11.3
32	5.3	6.9	8.1	8.7
34		4.6	5.6	6.1
36				3.7
(°)	52~83	52~83	54~83	51~83

Unit: ton				
19.1m Jib				
D (°) B (m)	0	15	30	40
	12	25.2		
14	24.7			
16	22.6	15.5		
18	20.9	14.5		
20	19.3	13.7	10.6	
22	17.8	12.9	10.2	9.0
24	16.5	12.2	9.8	8.7
26	15.4	11.6	9.4	8.4
28	13.5	11.1	9.1	8.2
30	11.0	10.5	8.8	8.0
32	8.8	10.1	8.5	7.7
34	6.6	8.9	8.2	7.5
36	4.6	6.9	7.9	7.2
38		5.0	6.7	7.0
40			4.8	5.5
42				3.6
(°)	54~83	56~83	57~83	55~83

Unit: ton				
27.1m Jib				
D (°) B (m)	0	15	30	40
	12	10.0		
14	10.0			
16	10.0			
18	10.0			
20	10.0	7.7		
22	10.0	7.3		
24	9.5	6.8		
26	8.8	6.4	5.0	
28	8.2	6.1	4.8	
30	7.7	5.8	4.6	4.1
32	7.2	5.5	4.5	4.0
34	6.7	5.2	4.3	3.9
36	6.3	5.0	4.1	3.7
38	6.0	4.8	4.0	3.6
40	4.8	4.6	3.9	3.5
42	3.4	4.4	3.7	3.5
44		4.2	3.6	3.4
46		3.1	3.5	3.3
48			3.4	3.2
50				2.9
(°)	53~83	55~83	57~83	56~83

Unit: ton				
35.1m Jib				
D (°) B (m)	0	15	30	40
	16	9.4		
18	8.5			
20	7.8			
22	7.2			
24	6.6	4.7		
26	6.2	4.4		
28	5.7	4.1		
30	5.3	3.9		
32	4.9	3.7	2.9	
34	4.6	3.5	2.7	
36	4.3	3.3	2.6	2.3
38	4.0	3.1	2.5	2.2
40	3.8	3.0	2.4	2.1
42	3.6	2.8	2.3	2.0
44	3.4	2.7	2.2	2.0
46	3.2	2.6	2.1	1.9
48		2.4	2.0	1.8
50		2.3	2.0	1.8
52		2.2	1.9	1.7
54			1.8	1.7
56			1.8	1.6
(°)	55~83	56~83	57~83	60~83

B= Working radius

D= Jib offset

= Boom angle range (for the unladen condition)

[51.0m Boom + 1.7m + Fully automatic luffing jib]
Performance C

D (°) B (m)		11.1m Jib				Unit: ton
		0	15	30	40	
10	26.4					
12	26.4					
14	26.4	21.2				
16	23.5	19.1	16.3			
18	20.9	17.2	15.0	13.9		
20	18.6	15.7	13.8	12.9		
22	16.7	14.3	12.7	11.9		
24	15.1	13.1	11.6	11.0		
26	13.7	11.9	10.7	10.2		
28	11.5	10.9	9.9	9.5		
30	8.9	10.0	9.1	8.8		
32	6.4	8.1	8.4	8.2		
34		5.7	7.0	7.5		
(°)	59~83	59~83	61~83	61~83	61~83	

D (°) B (m)		19.1m Jib				Unit: ton
		0	15	30	40	
14	18.0					
16	17.7					
18	15.7	12.1				
20	14.0	11.0				
22	12.5	10.0	8.4			
24	11.2	9.1	7.8	7.1		
26	10.1	8.4	7.2	6.7		
28	9.2	7.7	6.7	6.2		
30	8.3	7.0	6.2	5.9		
32	7.5	6.5	5.8	5.5		
34	6.9	6.0	5.4	5.1		
36		5.5	5.0	4.7		
38			4.6	4.4		
40			4.2	4.0		
42				3.8		
(°)	62~83	63~83	63~83	62~83	62~83	

D (°) B (m)		27.1m Jib				Unit: ton
		0	15	30	40	
16	10.0					
18	10.0					
20	10.0					
22	10.0	7.6				
24	9.6	7.2				
26	8.7	6.8				
28	7.9	6.4	5.0			
30	7.1	5.9	4.8			
32	6.5	5.5	4.6	4.1		
34	5.9	5.0	4.4	3.9		
36	5.4	4.7	4.1	3.8		
38	4.9	4.3	3.9	3.7		
40	4.5	4.0	3.6	3.5		
42		3.7	3.4	3.3		
44		3.4	3.2	3.0		
46			3.0	2.8		
48			2.7	2.6		
50				2.4		
(°)	60~83	62~83	63~83	63~83	63~83	

D (°) B (m)		35.1m Jib				Unit: ton
		0	15	30	40	
18	8.0					
20	8.0					
22	7.8					
24	7.2					
26	6.7	4.6				
28	6.3	4.3				
30	5.8	4.1				
32	5.5	3.9				
34	5.1	3.7	2.8			
36	4.8	3.5	2.7			
38	4.4	3.3	2.6	2.2		
40	4.0	3.2	2.5	2.2		
42	3.7	3.0	2.4	2.1		
44	3.3	2.9	2.3	2.0		
46		2.7	2.2	2.0		
48		2.5	2.1	1.9		
50		2.3	2.1	1.8		
52			2.0	1.8		
54			1.9	1.7		
56				1.7		
(°)	62~83	63~83	65~83	65~83	65~83	

B= Working radius

D= Jib offset

= Boom angle range (for the unladen condition)

[14.2m Boom + 1.7m + Fully automatic luffing jib]
Performance D

11.1m Jib					Unit: ton		
D (°)	B (m)	0	15	30	40		
		5	54.0	41.3			
6	54.0	37.3					
7	47.3	34.0	26.6				
8	41.9	31.2	24.9				
9	37.6	28.8	23.4	21.0			
10	34.0	26.7	22.1	19.9			
12	28.4	23.2	19.8	18.2			
14	24.2	20.5	18.0	16.8			
16	21.0	18.3	16.5	15.6			
18	18.5	16.6	15.3	14.8			
20	16.4	15.1	14.3	14.2			
22	14.6	13.9					
24	13.2						
(°)	0 ~ 83	28 ~ 83	33 ~ 83	42 ~ 83			

19.1m Jib					Unit: ton		
D (°)	B (m)	0	15	30	40		
		8	25.5				
9	23.6	18.0					
10	21.9	16.9					
12	19.0	15.0					
14	16.6	13.5	11.3				
16	14.7	12.2	10.4	9.5			
18	13.2	11.2	9.7	8.9			
20	11.9	10.2	8.9	8.3			
22	10.5	9.2	8.2	7.7			
24	9.4	8.4	7.6	7.2			
26	8.4	7.6	7.0	6.8			
28	7.5	7.0	6.6	6.5			
30	6.8	6.5					
32	6.1						
(°)	0 ~ 83	29 ~ 83	42 ~ 83	43 ~ 83			

27.1m Jib					Unit: ton		
D (°)	B (m)	0	15	30	40		
		8	10.0				
9	10.0						
10	10.0						
12	10.0	9.5					
14	10.0	8.5					
16	9.4	7.6					
18	8.3	6.9	5.8				
20	7.4	6.3	5.4				
22	6.7	5.7	5.0	4.6			
24	6.1	5.3	4.6	4.3			
26	5.6	4.9	4.3	4.0			
28	5.1	4.5	4.1	3.8			
30	4.7	4.2	3.8	3.6			
32	4.3	4.0	3.6	3.5			
34	4.0	3.7	3.5	3.3			
36	3.8	3.5	3.3	3.3			
38	3.5	3.4	3.3				
40	3.3						
(°)	0 ~ 83	31 ~ 83	36 ~ 83	47 ~ 83			

35.1m Jib					Unit: ton		
D (°)	B (m)	0	15	30	40		
		10	9.5				
12	9.2						
14	8.0						
16	7.0	5.7					
18	6.3	5.1					
20	5.6	4.6					
22	5.0	4.2					
24	4.5	3.9	3.3				
26	4.1	3.5	3.1				
28	3.7	3.3	2.8	2.6			
30	3.4	3.0	2.6	2.4			
32	3.1	2.8	2.5	2.3			
34	2.9	2.6	2.3	2.1			
36	2.7	2.4	2.2	2.0			
38	2.5	2.2	2.0	1.9			
40	2.3	2.1	1.9	1.8			
42	2.1	1.9	1.8	1.7			
44	1.9	1.8	1.7	1.7			
46	1.8	1.7	1.7				
48	1.7						
(°)	0 ~ 83	33 ~ 83	41 ~ 83	51 ~ 83			

B= Working radius

D= Jib offset

= Boom angle range (for the unladen condition)

[23.4m Boom + 1.7m + Fully automatic luffing jib]
Performance D

D (°) B (m)		11.1m Jib				Unit: ton
		0	15	30	40	
6	54.0					
7	54.0	39.4				
8	54.0	36.6				
9	52.1	34.2	25.6			
10	47.3	32.0	24.4			
12	39.7	28.4	22.3	19.8		
14	34.0	25.5	20.6	18.5		
16	28.0	23.1	19.1	17.4		
18	21.0	21.0	17.9	16.5		
20	15.8	18.0	16.8	15.7		
22	11.8	13.6	15.0	15.1		
24	8.6	10.0	11.1	11.6		
26	6.0	7.1	7.9	8.2		
28	3.4	4.5	5.1			
30	1.2	2.0				
(°)	28~83	29~83	38~83	45~83		

D (°) B (m)		19.1m Jib				Unit: ton
		0	15	30	40	
8	29.0					
9	27.2					
10	25.5					
12	22.6	16.4				
14	20.2	14.9				
16	18.0	13.7	11.1			
18	16.2	12.7	10.4	9.3		
20	14.7	11.8	9.8	8.9		
22	13.5	11.0	9.3	8.5		
24	12.4	10.3	8.8	8.0		
26	9.7	9.7	8.3	7.6		
28	7.4	9.0	7.8	7.2		
30	5.5	7.2	7.3	6.9		
32	3.7	5.3	6.5	6.7		
34			4.6	4.9		
36						
(°)	40~83	45~83	39~83	46~83		

D (°) B (m)		27.1m Jib				Unit: ton
		0	15	30	40	
8	10.0					
9	10.0					
10	10.0					
12	10.0					
14	10.0					
16	10.0	8.2				
18	9.8	7.5				
20	8.9	6.9	5.6			
22	8.1	6.4	5.2			
24	7.4	5.9	4.9	4.4		
26	6.8	5.5	4.7	4.2		
28	6.2	5.2	4.4	4.0		
30	5.8	4.9	4.2	3.9		
32	5.4	4.6	4.0	3.7		
34	5.0	4.3	3.8	3.6		
36	4.3	4.1	3.7	3.5		
38	3.0	3.9	3.5	3.4		
40	1.8	3.5	3.4	3.3		
42		2.1	3.3	3.2		
44			1.8			
(°)	34~83	38~83	41~83	49~83		

D (°) B (m)		35.1m Jib				Unit: ton
		0	15	30	40	
10	9.5					
12	9.5					
14	8.8					
16	7.8					
18	7.0					
20	6.4	4.9				
22	5.8	4.5				
24	5.3	4.2				
26	4.8	3.9				
28	4.4	3.6	3.0			
30	4.1	3.4	2.8			
32	3.8	3.1	2.6	2.4		
34	3.5	2.9	2.5	2.2		
36	3.2	2.7	2.4	2.1		
38	3.0	2.6	2.2	2.0		
40	2.8	2.4	2.1	1.9		
42	2.6	2.3	2.0	1.9		
44	2.2	2.2	1.9	1.8		
46	1.3	2.0	1.8	1.7		
48		1.9	1.8	1.7		
50		1.1	1.7	1.6		
(°)	37~83	41~83	48~83	51~83		

B= Working radius

D= Jib offset

= Boom angle range (for the unladen condition)

[32.6m Boom + 1.7m + Fully automatic luffing jib]
Performance D

11.1m Jib					Unit: ton
D (°)	B (m)	0	15	30	40
		9	54.0	38.2	
10	54.0	36.1			
12	50.6	32.5	24.0		
14	35.8	29.5	22.4	19.6	
16	26.1	26.9	21.0	18.7	
18	19.1	22.3	19.8	17.8	
20	14.0	16.7	18.7	17.0	
22	10.0	12.3	14.2	15.2	
24	6.8	8.8	10.4	11.2	
26		5.9	7.3	7.9	
28				5.0	
(°)	55~83	55~83	57~83	55~83	55~83

19.1m Jib					Unit: ton
D (°)	B (m)	0	15	30	40
		10	25.3		
12	24.8				
14	22.4	15.7			
16	20.4	14.6			
18	18.6	13.6	10.8		
20	17.0	12.8	10.2	9.1	
22	13.6	12.0	9.8	8.8	
24	10.3	11.3	9.4	8.5	
26	7.7	10.5	9.0	8.2	
28	5.4	7.9	8.6	7.9	
30		5.8	7.7	7.5	
32			5.6	6.5	
34				4.5	
(°)	56~83	59~83	60~83	59~83	59~83

27.1m Jib					Unit: ton
D (°)	B (m)	0	15	30	40
		12	10.0		
14	10.0				
16	10.0				
18	10.0	7.9			
20	10.0	7.4			
22	9.3	6.9			
24	8.5	6.4	5.1		
26	7.8	6.0	4.9	4.3	
28	7.3	5.7	4.7	4.2	
30	6.7	5.4	4.4	4.0	
32	5.0	5.1	4.3	3.9	
34		4.8	4.1	3.7	
36		4.6	3.9	3.6	
38			3.8	3.5	
40			3.7	3.4	
42				3.2	
(°)	57~83	59~83	60~83	60~83	60~83

35.1m Jib					Unit: ton
D (°)	B (m)	0	15	30	40
		14	9.5		
16	8.6				
18	7.8				
20	7.1				
22	6.5	4.8			
24	6.0	4.5			
26	5.5	4.2			
28	5.1	3.9			
30	4.7	3.6	2.9		
32	4.4	3.4	2.8		
34	4.1	3.2	2.6	2.3	
36	3.8	3.0	2.5	2.2	
38		2.9	2.4	2.1	
40		2.7	2.3	2.0	
42		2.6	2.2	2.0	
44			2.1	1.9	
46			2.0	1.8	
48				1.8	
(°)	59~83	61~83	62~83	63~83	63~83

B= Working radius

D= Jib offset

= Boom angle range (for the unladen condition)

[41.8m Boom + 1.7m + Fully automatic luffing jib]

Performance D

		11.1m Jib				Unit: ton
D (°)	B (m)	0	15	30	40	
		10	41.3			
12	41.3	35.8				
14	36.0	32.7	23.8			
16	26.2	30.2	22.5	19.5		
18	19.3	22.6	21.3	18.7		
20	14.1	16.9	19.4	18.0		
22	10.1	12.6	14.6	15.7		
24		9.1	10.8	11.8		
26			7.8	8.5		
(°)		64~83	65~83	64~83	65~83	

		19.1m Jib				Unit: ton
D (°)	B (m)	0	15	30	40	
		12	25.2			
14	24.7					
16	22.6	15.5				
18	20.9	14.5				
20	17.4	13.7	10.6			
22	13.3	12.9	10.2	9.0		
24	10.0	12.2	9.8	8.7		
26		10.3	9.4	8.4		
28		7.8	9.1	8.2		
30			7.8	8.0		
32				6.7		
(°)		66~83	67~83	68~83	68~83	

		27.1m Jib				Unit: ton
D (°)	B (m)	0	15	30	40	
		12	10.0			
14	10.0					
16	10.0					
18	10.0					
20	10.0	7.7				
22	10.0	7.3				
24	9.5	6.8				
26	8.8	6.4	5.0			
28	8.1	6.1	4.8			
30	6.1	5.8	4.6	4.1		
32		5.5	4.5	4.0		
34		5.2	4.3	3.9		
36			4.1	3.7		
38			4.0	3.6		
40				3.5		
(°)		64~83	66~83	67~83	68~83	

		35.1m Jib				Unit: ton
D (°)	B (m)	0	15	30	40	
		16	9.4			
18	8.5					
20	7.8					
22	7.2					
24	6.6	4.7				
26	6.2	4.4				
28	5.7	4.1				
30	5.3	3.9				
32	4.9	3.7	2.9			
34		3.5	2.7			
36		3.3	2.6	2.3		
38			2.5	2.2		
40			2.4	2.1		
42			2.3	2.0		
44				2.0		
(°)		66~83	70~83	70~83	72~83	

B= Working radius

D= Jib offset

= Boom angle range (for the unladen condition)

[51.0m Boom + 1.7m + Fully automatic luffing jib]
Performance D

Unit: ton				
11.1m Jib				
D (°) B (m)	0	15	30	40
	10	26.4		
12	26.4			
14	26.4	21.2		
16	23.5	19.1	16.3	
18	20.3	17.2	15.0	13.9
20	15.1	15.7	13.8	12.9
22	11.1	13.5	12.7	11.9
24			11.6	11.0
26				9.6
(°)	69~83	71~83	71~83	70~83

Unit: ton				
19.1m Jib				
D (°) B (m)	0	15	30	40
	14	18.0		
16	17.7			
18	15.7	12.1		
20	14.0	11.0		
22	12.5	10.0	8.4	
24	10.5	9.1	7.8	7.1
26		8.4	7.2	6.7
28		7.7	6.7	6.2
30			6.2	5.9
(°)	70~83	70~83	72~83	73~83

Unit: ton				
27.1m Jib				
D (°) B (m)	0	15	30	40
	16	10.0		
18	10.0			
20	10.0			
22	10.0	7.6		
24	9.6	7.2		
26	8.7	6.8		
28	7.9	6.4	5.0	
30		5.9	4.8	
32		5.5	4.6	4.1
34		5.0	4.4	3.9
36			4.1	3.8
38			3.9	3.7
(°)	69~83	70~83	71~83	73~83

Unit: ton				
35.1m Jib				
D (°) B (m)	0	15	30	40
	18	8.0		
20	8.0			
22	7.8			
24	7.2			
26	6.7	4.6		
28	6.3	4.3		
30	5.8	4.1		
32		3.9		
34		3.7	2.8	
36		3.5	2.7	
38		3.3	2.6	2.2
40			2.5	2.2
42			2.4	2.1
44				2.0
(°)	71~83	71~83	73~83	74~83

B= Working radius

D= Jib offset

= Boom angle range (for the unladen condition)

WORKING RADIUS - LIFTING HEIGHT

[14.2m Boom + 1.7m + Fully automatic luffing jib]

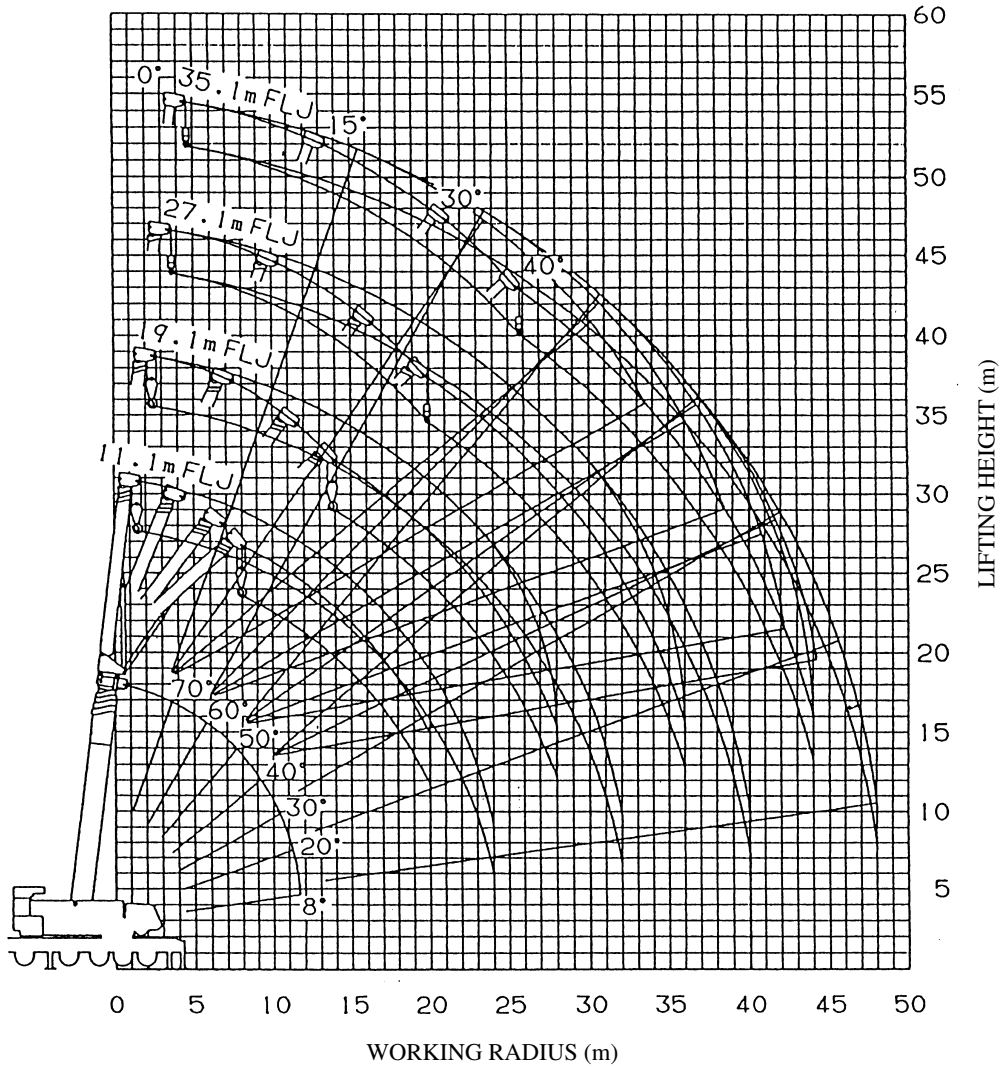

NOTES:

1. The deflection of the boom is not incorporated in the figure above.
2. The above chart is for Performance A.

[23.4m Boom + 1.7m + Fully automatic luffing jib]

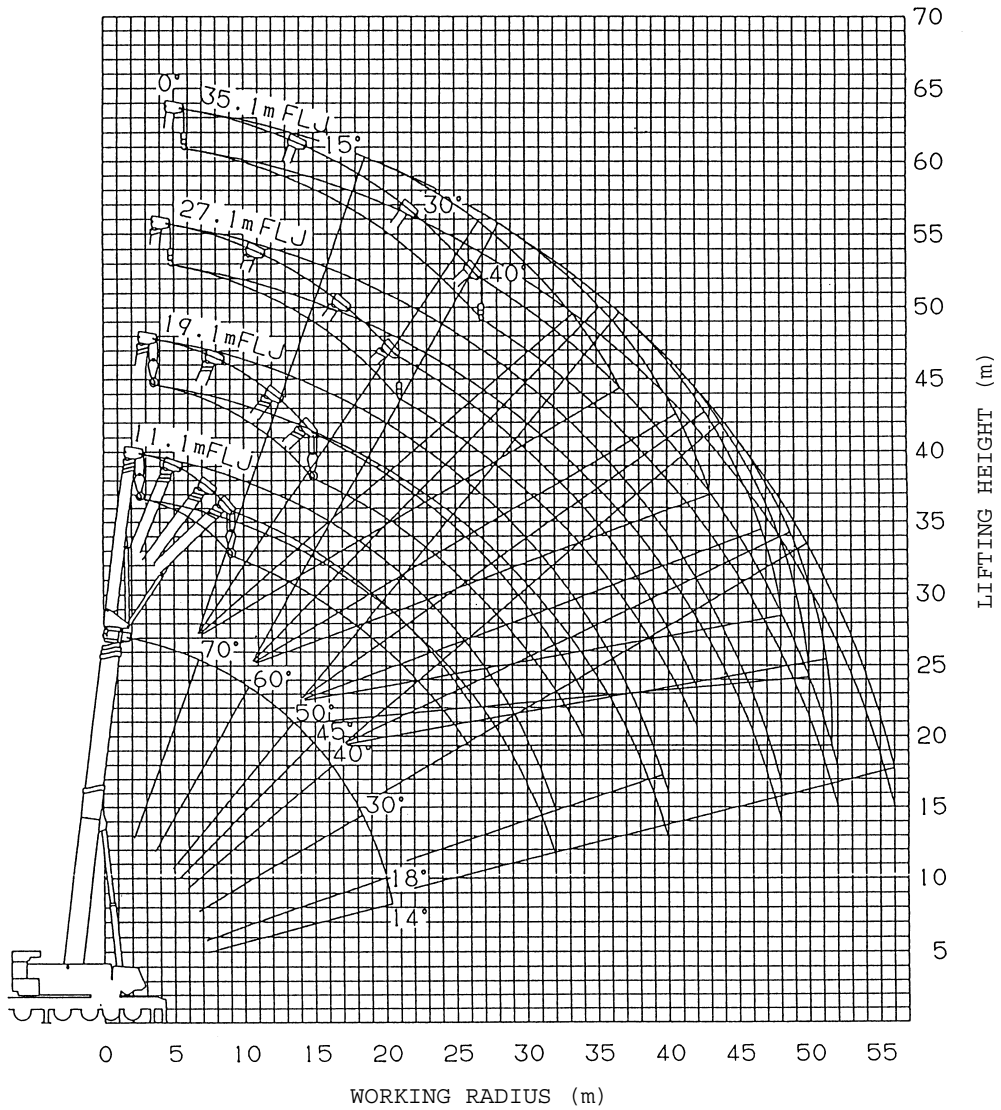

NOTES:

1. The deflection of the boom is not incorporated in the figure above.
2. The above chart is for Performance A.

[32.6m Boom + 1.7m + Fully automatic luffing jib]

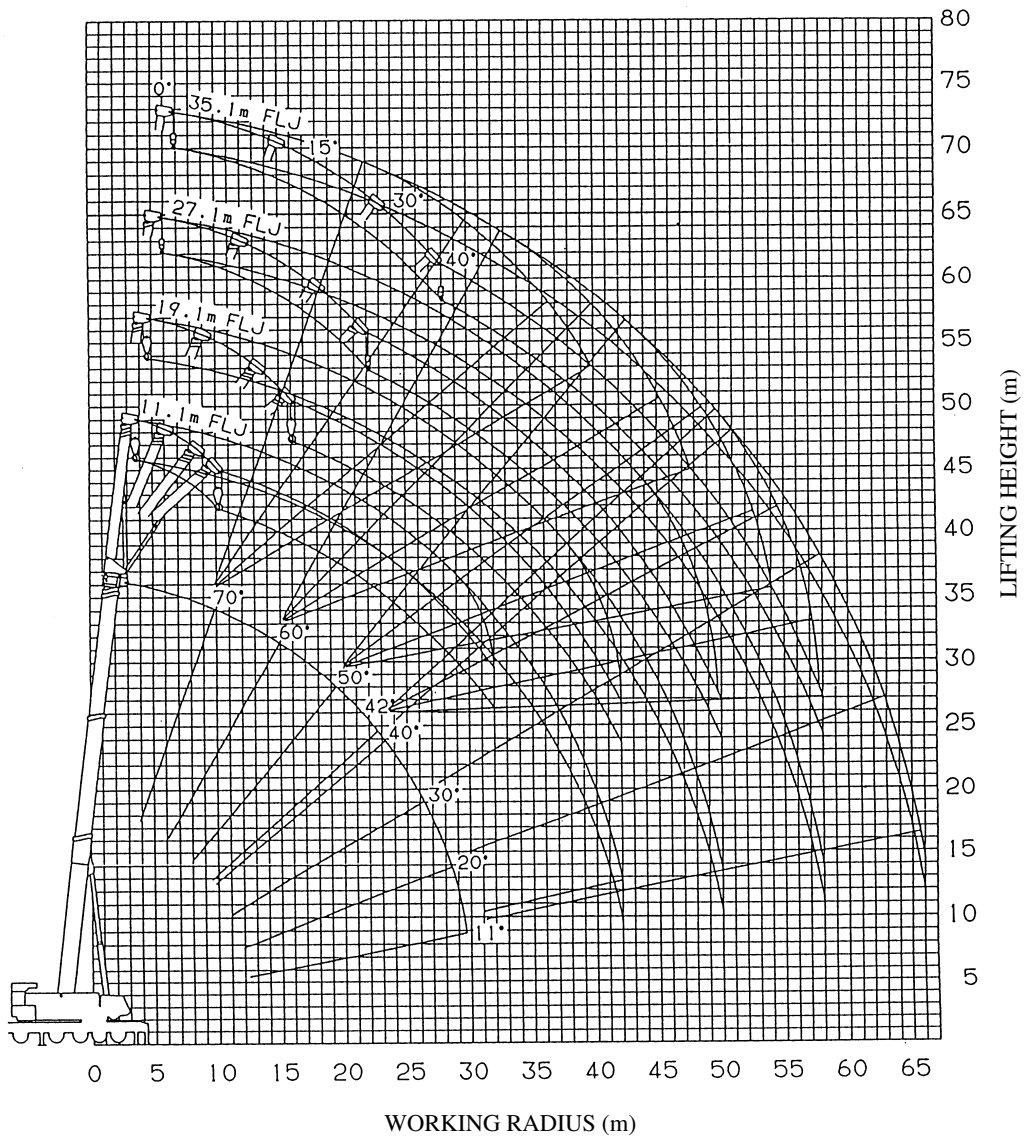

NOTES:

1. The deflection of the boom is not incorporated in the figure above.
2. The above chart is for Performance A.

[41.8m Boom + 1.7m + Fully automatic luffing jib]

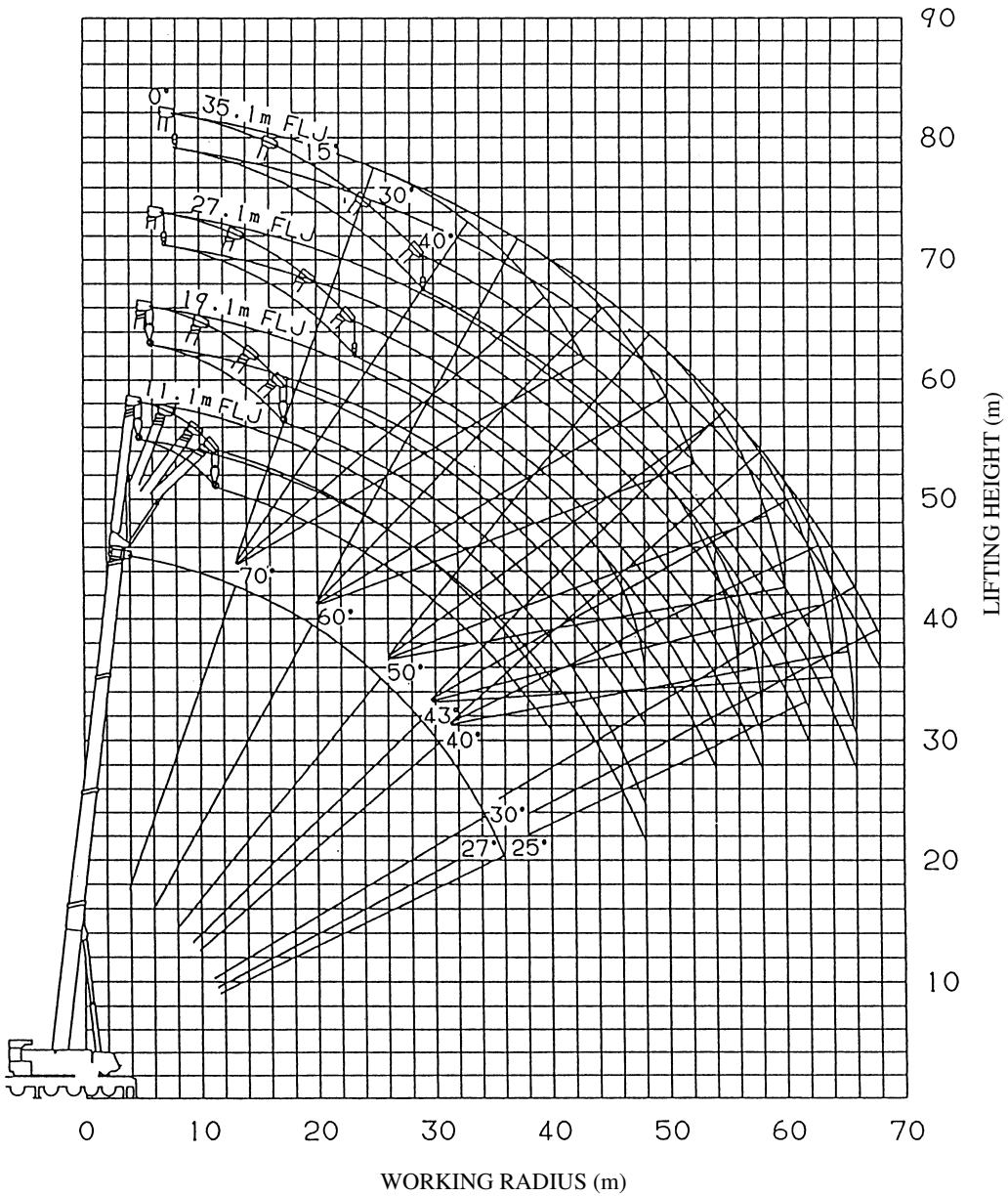

NOTES:

1. The deflection of the boom is not incorporated in the figure above.
2. The above chart is for Performance A.

[51.0m Boom + 1.7m + Fully automatic luffing jib]

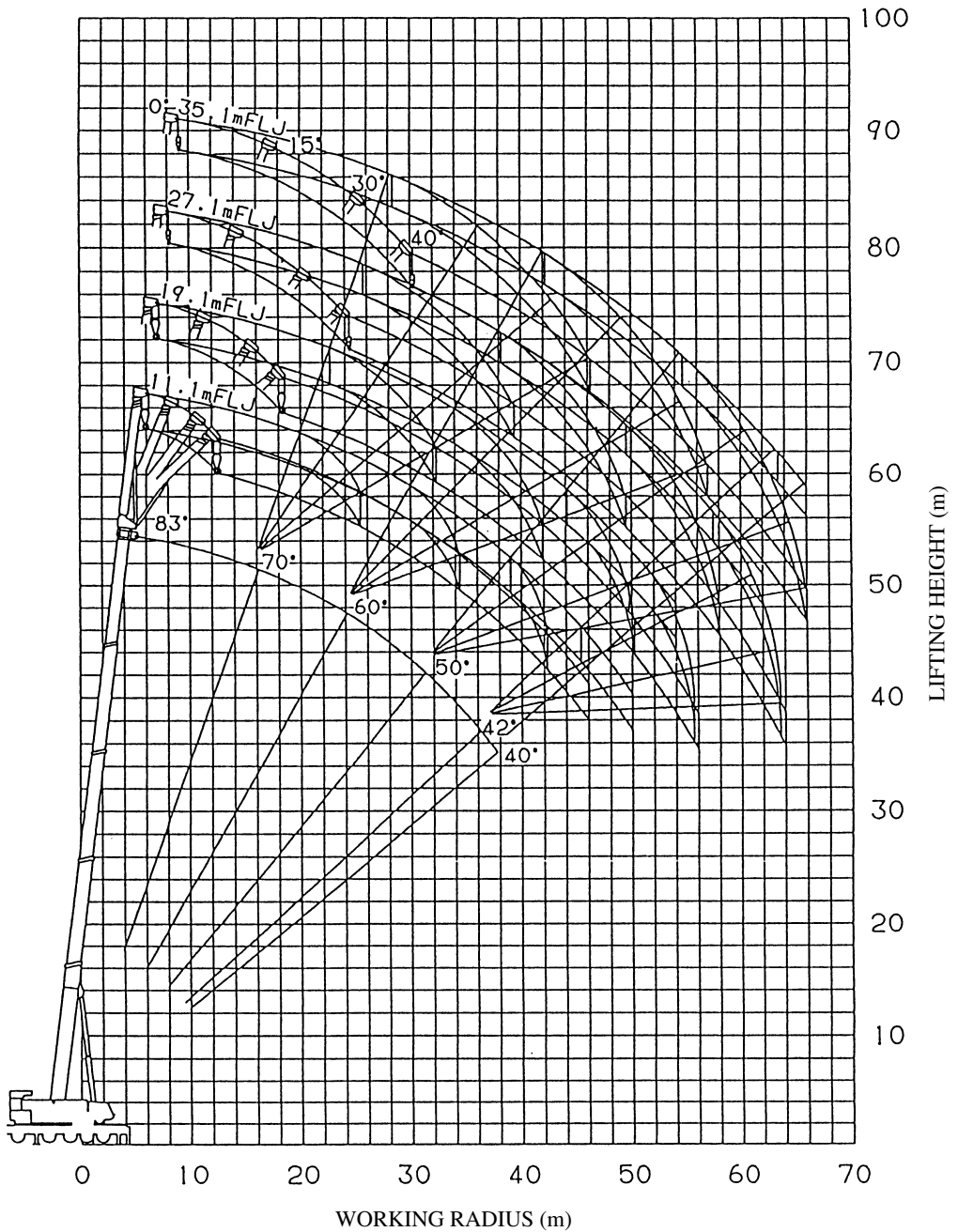

NOTES:

1. The deflection of the boom is not incorporated in the figure above.
2. The above chart is for Performance A.

TRUCK CRANE

TG-3600M

JAPANESE SPECIFICATIONS

TG

These specifications are for the optional luffing jib for the TG-3600M type crane.
Refer to these specifications along with specification control no. TG-3600M-2/MB-80.

Control No. TG-3600M-2/LJ-80

TG-3600M

CRANE SPECIFICATIONS

CRANE CAPACITY

17m	Jib	100,000kg	at 10.0m (9part-line)
23m	Jib	80,000kg	at 12.0m (8part-line)
35m	Jib	51,600kg	at 16.0m (6part-line)
47m	Jib	31,000kg	at 18.0m (4part-line)
*65m	Jib	8,000kg	at 35.0m (1part-line)
*70m	Jib	5,000kg	at 55.0m (1part-line)

For the mark *, luffing jib (47m) + extension jib

Jib

Lattice type

JIB LENGTH

4.8m (fixed part) + 17.0m, 23.0m, 35.0m, 47.0m, *65.0m, *70.0m (elevating part)

For the mark *, luffing jib (47m) + extension jib

MAX.LIFTING HEIGHT

98.0m (9.5t)

119.0m (3.5t) (luffing jib + extension jib)

MAX.WORKING RADIUS

70.0m (3.9t)

90.0m (3.2t) (luffing jib + extension jib)

TOTAL RATED LOADS

- The total rated loads shown are for the case where the outriggers are set horizontally on firm level ground. The values above the bold lines are based on the crane strength while those below are based on the crane stability.
- The weights of the slings and hooks are included in the total rated loads shown.
- The total rated load is based on the actual working radius including the deflection of the boom and jib.
- The chart below shows the standard hook and number of part lines under each working condition.

Jib length (m)		17	23	35	47	47 + 18	47 + 23
14.2m Boom	M	100.0	80.0	51.6	31.0	/	/
	H	9(4)	8(3)	6(2)	4(2)		
	N	180	180	80	80		
	L	2,400	2,400	1,360	1,360		
22.6m Boom	M	71.0	63.5	45.0	27.0	/	/
	H	7(4)	6(3)	4(2)	4(2)		
	N	180	80	80	80		
	L	2,400	1,360	1,360	1,360		
31.0m Boom	M	60.0	43.7	35.0	20.0	8.0	5.0
	H	6(4)	4(3)	4(2)	2(2)	1	1
	N	180	80	80	25	12.5	12.5
	L	2,400	1,360	1,360	730	490	490
39.4m Boom	M	/	/	22.0	14.5	6.5	5.0
	H			2(2)	2(2)	1	1
	N			25	25	12.5	12.5
	L			730	730	490	490
47.8m Boom	M	/	/	13.0	9.5	4.5	3.5
	H			2(2)	2(2)	1	1
	N			25	25	12.5	12.5
	L			730	730	490	490





M= Max. total rated loads (t) H= No. of part-lines

N= Hook lifting capacity (t) L= Hook weight (kg)

- To prevent the jib from toppling over in the over-rear area, operations should be performed with the minimum number of part lines in parentheses or more even if the load is small.
- Boom length and boom fixing pin
The boom telescoping order, stroke of each boom, boom length, boom fixing pin condition when the boom and jib are used are as follows.
 - Boom telescoping order and stroke of each boom
 - Extend the boom from the base boom side, and then extend the next boom when the boom is extended by the strokes shown in the following table.
 - Retract the boom from the top boom side, and then retract the next boom when the boom is retracted by the strokes shown in the following table.

Crane service condition	Boom stroke
Luffing jib	8.4m

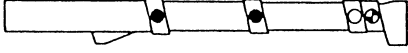
2) Boom length and boom fixing pin status

Boom length (m)		Pin condition when the boom fixing pin is used	● Pin inserted
Boom Fully automatic luffing jib	Boom Luffing jib		○ Pin removed
14.2	14.2		● Both pin insertion and removal are available.
23.4	22.6		
32.6	31.0		
41.8	39.4		
51.0	47.8		

- When the boom is operated, when the boom is extended to the middle, and when at least one boom fixing pin condition marked with ○ in the above chart is ●, the performance for the case where the boom fixing pin is not used shall apply.
- When operating the jib (fully automatic luffing jib, luffing jib), the boom length and the boom fixing pin condition must be in accordance with the above chart.

6. As shown in the following table, the performance depends on the outrigger installation condition and counterweight combination.

Counterweight	100t	85t	65t
Outrigger extension width			
8.8m	S	A	B

- Both of the front and rear jacks should be used.
- The boom fixing pin should be used.

[4.8m + 17m Luffing jib]
Performance S

A	14.2m							22.6m							31.0m							Unit: ton
	83	77	70	65	60	55	50	83	77	70	65	60	55	50	83	77	70	65	60	55		
E(°)																						
B(m)																						
8	100.0																					
9	94.6																					
10	84.3	100.0						71.0														
12	69.1	83.8						63.1							60.0							
14	53.3	68.7	83.0					54.9	66.8						53.9							
16	36.5	56.8	70.1	73.4				46.2	59.4						47.0	59.7						
18		39.8	59.1	67.1					51.7	64.5					39.2	53.5						
20			46.1	57.0	61.3				41.7	57.9	56.8					47.2						
22				44.3	54.7	54.4				50.6	51.1					39.6	49.6					
24						49.1	47.9				45.9	43.5					44.6	41.3				
26							43.4				41.1	39.5					40.5	37.4				
28												36.0	34.2					34.2	31.5			
30													31.4	29.8					29.0			
32														27.5					26.7	24.6		
34																				22.8		

A= Boom length B= Working radius
E= Boom angle

[4.8m + 23m Luffing jib]
Performance S

A	14.2m							22.6m							31.0m							Unit: ton
	83	77	70	65	60	55	50	83	77	70	65	60	55	50	83	77	70	65	60	55	50	
E(°)																						
B(m)	80.0							63.5							43.7							
		80.0							59.8							43.7						
			60.5							54.4							43.7					
				58.3				40.2	49.2	57.5					39.4	43.7						
					50.5			31.4	44.0	52.9					34.6	43.7						
		26.5	40.0	44.5	48.7				38.0	48.2	45.5				27.9	39.7	43.7					
			30.8	39.6	43.0	44.2			27.9	43.4	41.3					35.2	40.2					
				30.1	38.5	40.4	39.3			37.3	37.8	35.7				28.8	36.7	33.8				
						37.2	36.2				34.8	32.8					33.8	31.1				
							33.5				28.5	30.3	28.6				31.2	28.7	26.3			
												28.1	26.6	25.1				26.6	24.4			
													24.8	23.4					22.7	20.8		
														21.8					21.2	19.4		
																			18.2	16.5		
																				15.5		

A= Boom length B= Working radius
E= Boom angle

[4.8m + 35m Luffing jib]
Performance S

A	14.2m							22.6m							31.0m							Unit: ton
	83	77	70	65	60	55	50	83	77	70	65	60	55	50	83	77	70	65	60	55	50	
E(°)																						
B(m)	16	51.6																				
	18	45.2	51.5				45.0															
	20	40.0	45.0				43.5								35.0							
	22	35.9	39.9				39.0	44.9							35.0							
	24	32.5	35.8	40.4			35.0	40.8							34.6	35.0						
	26	29.0	32.4	36.2			31.7	36.5	43.0						31.9	35.0						
	28	25.0	29.5	32.7	35.3		28.9	33.0	39.0						29.3	34.4						
	30	21.2	26.7	29.8	32.0		25.0	30.0	35.0						26.7	31.9	32.7					
	32	17.4	22.9	27.3	29.2	31.2	21.0	27.5	31.7	31.4					23.8	29.6	30.2					
	34	13.0	19.1	25.2	26.8	28.5	16.8	24.4	29.0	29.1					19.8	27.2	28.0					
	36		14.6	21.5	24.7	26.2	27.7	20.5	26.6	27.2	25.5				15.0	24.8	26.1	23.8				
	38			17.2	21.9	24.2	25.5	15.6	24.5	25.4	23.8					20.9	24.4	22.2				
	40				17.2	22.0	23.6		20.8	23.8	22.3	20.9				15.9	22.9	20.8	18.8			
	42						21.9			22.4	21.0	19.7					21.5	19.6	17.7			
	44									16.7	19.8	18.5	17.3				18.6	18.4	16.6			
	46										18.7	17.5	16.4					17.4	15.7	14.1		
	48											16.5	15.5						14.8	13.3		
	50												14.7						14.0	12.6		
	55																				11.2	9.8

A= Boom length B= Working radius
E= Boom angle

[4.8m + 35m Luffing jib]
Performance S

A	39.4m							47.8m					Unit: ton
	83	77	70	65	60	55	50	83	77	70	65	60	
E(°)													
B(m)													
20	22.0												
22	22.0							13.0					
24	22.0							13.0					
26	22.0	22.0						13.0					
28	21.4	22.0						13.0	13.0				
30	19.6	22.0						13.0	13.0				
32	17.8	22.0						13.0	13.0				
34	16.0	20.5	22.0					13.0	13.0				
36	13.9	18.9	21.8					11.6	13.0				
38		17.2	20.6					10.0	13.0	12.9			
40		15.4	19.7	17.9					13.0	12.2			
42		13.2	18.8	17.0					11.8	11.7			
44			17.2	16.2					10.2	11.2	9.9		
46			15.5	15.6	13.6					10.8	9.4		
48				14.7	12.8					10.5	9.0		
50				13.9	12.1	10.4				10.4	8.6	7.6	
55												6.8	6.0
60													5.3

A= Boom length B= Working radius
E= Boom angle

[4.8m + 47m Luffing jib]
Performance S

A	39.4m						47.8m						Unit: ton	
	83	77	70	65	60	55	50	83	77	70	65	60		55
E(°)														
B(m)														
24	14.5													
26	14.5							9.5						
28	14.5							9.5						
30	14.5							9.5						
32	14.5	14.5						9.5						
34	14.5	14.5						9.5	9.5					
36	14.5	14.5						9.5	9.5					
38	14.5	14.5						9.5	9.5					
40	13.4	14.5						9.5	9.5					
42	12.3	14.5	14.5					9.5	9.5					
44	11.1	14.2	14.5					8.6	9.5	9.3				
46	9.9	13.1	14.5					7.7	9.5	8.8				
48	8.5	12.0	14.5	13.4				6.8	9.5	8.4				
50		10.9	14.1	12.8				5.7	8.8	8.1	7.1			
55			11.7	11.2	9.5				6.5	7.4	6.2			
60				9.8	8.3	6.8				7.0	5.6	4.7		
65					7.2	5.9	4.5				5.3	4.1	3.4	
70							3.7					3.9	3.0	

A= Boom length B= Working radius
E= Boom angle

[4.8m + 47m Luffing jib + 18m Extension jib]
Performance S

A	31.0m							39.4m							47.8m							Unit: ton
	83	77	70	65	60	55	50	83	77	70	65	60	55	83	77	70	65	60				
E(°)																						
B(m)																						
30	8.0							6.5														
35	8.0							6.5						4.5								
40	7.4	7.6						6.5	6.5					4.5								
45	6.9	7.1						6.5	6.5					4.5	4.5							
50	6.5	6.6	6.8					6.5	6.5					4.5	4.5							
55	6.0	6.2	6.4	6.5				6.1	6.3	6.5				4.5	4.5	4.5						
60	5.6	5.8	6.0	6.1				5.7	6.0	6.1	6.3			4.5	4.5	4.5						
65	5.4	5.5	5.7	5.8	5.9			5.4	5.6	5.8	5.9			4.1	4.5	4.5	4.1					
70		5.3	5.4	5.5	5.6	5.7			5.3	5.5	5.6	5.7			4.5	4.5	3.6					
75				5.2	5.3	5.4	5.1			5.2	5.4	5.4	4.3			4.2	3.3	2.6				
80				5.1	5.2	5.2	4.5				5.1	4.9	3.7			4.0	3.0	2.3				
85							3.9						3.1					1.9				

A= Boom length B= Working radius
E= Boom angle

[4.8m + 47m Luffing jib + 23m Extension jib]
Performance S

A	31.0m						39.4m						47.8m					
	83	77	70	65	60	55	50	83	77	70	65	60	55	83	77	70	65	60
E(°)																		
B(m)	5.0							5.0						5.0				
	5.0							5.0						3.5				
	5.0	5.0						5.0	5.0					3.5	3.5			
	5.0	5.0						4.7	5.0					3.5	3.5			
	4.6	4.9						4.3	4.6	5.0				3.5	3.5			
	4.2	4.5	4.8					3.9	4.2	4.5				3.5	3.5	3.5		
	3.9	4.1	4.3	4.5				3.6	3.9	4.1	4.4			3.5	3.5	3.5		
	3.6	3.8	4.0	4.1				3.4	3.6	3.8	4.0			3.4	3.5	3.5	3.4	
	3.4	3.5	3.7	3.8	3.9			3.4	3.4	3.5	3.7	3.8		3.4	3.4	3.5	3.0	
		3.3	3.4	3.5	3.6	3.7												
				3.3	3.4	3.5	3.6			3.3	3.4	3.5	3.4			3.4	2.7	1.9
					3.2	3.3	3.3				3.2	3.3	2.9			3.2	2.5	1.4
							3.2						2.4					

Unit: ton

A= Boom length B= Working radius
E= Boom angle

[4.8m + 17m Luffing jib]
Performance A

A	14.2m							22.6m							31.0m							Unit: ton
	83	77	70	65	60	55	50	83	77	70	65	60	55	50	83	77	70	65	60	55		
E(°)																						
B(m)	100.0																					
8																						
9	94.6																					
10	84.3	100.0						71.0														
12	69.1	83.8						63.1							60.0							
14	53.3	68.7	83.0					54.9	66.8						53.9							
16	36.5	56.8	70.1	73.4				46.2	59.4						47.0	59.7						
18		39.8	59.1	67.1					51.7	62.9					39.2	53.5						
20			46.1	57.0	57.6				41.7	55.2	52.0					47.2						
22				44.3	51.3	49.8				49.1	46.3					39.6	44.9					
24						44.8	43.5				41.6	39.2					40.3	36.9				
26							39.5				37.7	35.5					36.5	33.5				
28												32.4	30.5					30.6	27.9			
30													28.0	26.4					25.6			
32														24.3					23.6	21.4		
34																				19.8		

A= Boom length B= Working radius
E= Boom angle

[4.8m + 35m Luffing jib]
Performance A

A	14.2m							22.6m							31.0m							Unit: ton
	83	77	70	65	60	55	50	83	77	70	65	60	55	50	83	77	70	65	60	55	50	
E(°)																						
B(m)	16	51.6																				
	18	45.2	51.5				45.0															
	20	40.0	45.0				43.5								35.0							
	22	35.9	39.9				39.0	44.9							35.0							
	24	32.5	35.8	40.4			35.0	40.8							34.6	35.0						
	26	29.0	32.4	36.2			31.7	36.5	39.1						31.9	35.0						
	28	25.0	29.5	32.7	35.3		28.9	33.0	35.7						29.3	34.4						
	30	21.2	26.7	29.8	32.0		25.0	30.0	32.8						26.7	31.9	29.4					
	32	17.4	22.9	27.3	29.2	31.2	21.0	27.5	30.3	28.3					23.8	29.6	27.1					
	34	13.0	19.1	25.2	26.8	28.5	16.8	24.4	28.1	26.2					19.8	27.2	25.1					
	36		14.6	21.5	24.7	26.2		20.5	26.2	24.4	22.7				15.0	24.8	23.3	21.0				
	38			17.2	21.9	24.2		15.6	24.5	22.8	21.2					20.9	21.8	19.6				
	40				17.2	22.0			20.8	21.4	19.9	18.5				15.9	20.4	18.4	16.4			
	42									20.1	18.7	17.3					19.2	17.2	15.4			
	44									16.7	17.6	16.3	15.1				18.0	16.2	14.4			
	46										16.6	15.4	14.3					15.3	13.6	12.0		
	48											14.5	13.5						12.8	11.3		
	50												12.7						12.1	10.6	9.3	
	52																				8.0	

A= Boom length B= Working radius
E= Boom angle

[4.8m + 35m Luffing jib]
Performance A

A	39.4m							47.8m					Unit: ton
	83	77	70	65	60	55	50	83	77	70	65	60	
E(°)													
B(m)													
20	22.0												
22	22.0							13.0					
24	22.0							13.0					
26	22.0	22.0						13.0					
28	21.4	22.0						13.0	13.0				
30	19.6	22.0						13.0	13.0				
32	17.8	22.0						13.0	13.0				
34	16.0	20.5	22.0					13.0	13.0				
36	13.9	18.9	21.5					11.6	13.0				
38		17.2	20.0					10.0	13.0	12.9			
40		15.4	18.8	16.3					13.0	12.2			
42		13.2	17.6	15.3					11.8	11.7			
44			16.5	14.4					10.2	11.2	9.9		
46			15.5	13.5	11.5					10.8	9.4		
48				12.7	10.8					10.5	9.0		
50				12.0	10.2	8.5				10.4	8.6	7.6	
55						7.3	5.7					6.8	5.2
60							4.7						4.3

A= Boom length B= Working radius
E= Boom angle

[4.8m + 47m Luffing jib]
Performance A

A	14.2m						22.6m						31.0m						Unit: ton			
	83	77	70	65	60	55	50	83	77	70	65	60	55	50	83	77	70	65		60	55	50
E(°)																						
B(m)	18	31.0																				
	20	30.4					27.0															
	22	28.4	30.3				27.0								20.0							
	24	26.7	28.4				27.0								20.0							
	26	25.2	26.7				26.0	27.0							20.0							
	28	23.9	25.2				24.6	26.7							20.0							
	30	22.4	23.9	25.3			23.3	25.2							20.0	20.0						
	32	20.9	22.3	24.0			21.8	23.8							20.0	20.0						
	34	19.4	20.7	22.3	23.5		20.3	22.3	24.6						20.0	20.0						
	36	18.2	19.3	20.7	21.8		18.9	20.7	23.1						19.0	20.0						
	38	16.2	18.0	19.3	20.3		17.7	19.3	21.4	21.7					17.8	20.0	20.0					
	40	14.0	16.9	18.1	18.9	19.8	16.2	18.0	19.9	20.3					16.6	18.6	19.7					
	42	11.9	15.4	16.9	17.7	18.5	14.0	16.9	18.6	19.0					15.6	17.4	18.5	16.5				
	44	9.8	13.3	15.9	16.6	17.3	11.9	15.9	17.4	17.9	16.5				14.0	16.3	17.4	15.5				
	46	7.1	11.1	15.0	15.6	16.2	9.4	14.1	16.3	16.8	15.5				11.6	15.3	16.4	14.5				
	48		8.3	12.8	14.7	15.3	11.9	15.3	15.9	14.6	13.4				8.6	14.4	15.4	13.7	12.0			
	50			10.2	13.3	14.4	9.0	14.5	15.0	13.8	12.7					12.6	14.6	12.9	11.3			
	55						12.1	13.5									12.7	11.2	9.8	8.4		
	60																		8.5	7.3		
	65																				6.1	5.3

A= Boom length B= Working radius
E= Boom angle

[4.8m + 47m Luffing jib]
Performance A

A	39.4m						47.8m						Unit: ton
	83	77	70	65	60	55	50	83	77	70	65	60	
E(°)													
B(m)													
24	14.5												
26	14.5							9.5					
28	14.5							9.5					
30	14.5							9.5					
32	14.5	14.5						9.5					
34	14.5	14.5						9.5	9.5				
36	14.5	14.5						9.5	9.5				
38	14.5	14.5						9.5	9.5				
40	13.4	14.5						9.5	9.5				
42	12.3	14.5	14.5					9.5	9.5				
44	11.1	14.2	14.5					8.6	9.5	9.3			
46	9.9	13.1	14.5					7.7	9.5	8.8			
48	8.5	12.0	13.7	11.6				6.8	9.5	8.4			
50		10.9	12.9	10.9				5.7	8.8	8.1	7.1		
55			11.3	9.5	7.7				6.5	7.4	6.2		
60				8.2	6.7	5.0				7.0	5.6	4.7	
65					5.7	4.2	2.5				5.3	4.1	2.1
70						1.9						3.3	1.5

A= Boom length B= Working radius
E= Boom angle

[4.8m + 47m Luffing jib + 18m Extension jib]
Performance A

A	31.0m						39.4m						47.8m						Unit: ton
	83	77	70	65	60	55	50	83	77	70	65	60	55	83	77	70	65	60	
E(°)																			
B(m)																			
30	8.0							6.5											
35	8.0							6.5						4.5					
40	7.4	7.6						6.5	6.5					4.5					
45	6.9	7.1						6.5	6.5					4.5	4.5				
50	6.5	6.6	6.8					6.5	6.5					4.5	4.5				
55	6.0	6.2	6.4	6.5				6.1	6.3	6.5				4.5	4.5	4.5			
60	5.6	5.8	6.0	6.1				5.7	6.0	6.1	6.3			4.5	4.5	4.5			
65	5.4	5.5	5.7	5.8	5.9			5.4	5.6	5.8	5.9			4.1	4.5	4.5	4.1		
70		5.3	5.4	5.5	5.6	5.5			5.3	5.5	5.6	5.0		4.5	4.5	4.5	3.6		
75				5.2	5.3	4.8	3.7			5.2	5.4	4.2	2.7			4.2	3.3	2.6	
80					5.1	4.2	3.1				4.9	3.6	2.1			4.0	3.0	2.0	
85							2.5						1.6					1.6	

A= Boom length B= Working radius
E= Boom angle

[4.8m + 47m Luffing jib + 23m Extension jib]
Performance A

A	31.0m						39.4m						47.8m						
	83	77	70	65	60	55	50	83	77	70	65	60	55	83	77	70	65	60	
E(°)																			
B(m)	5.0							5.0						5.0					
	5.0							5.0						3.5					
	5.0	5.0						5.0	5.0					3.5	3.5				
	5.0	5.0						4.7	5.0					3.5	3.5				
	4.6	4.9						4.3	4.6	5.0				3.5	3.5				
	4.2	4.5	4.8					3.9	4.2	4.5				3.5	3.5	3.5			
	3.9	4.1	4.3	4.5				3.6	3.9	4.1	4.4			3.5	3.5	3.5			
	3.6	3.8	4.0	4.1				3.4	3.6	3.8	4.0			3.4	3.5	3.5	3.4		
	3.4	3.5	3.7	3.8	3.9			3.4	3.4	3.5	3.7	3.8		3.4	3.4	3.5	3.0		
		3.3	3.4	3.5	3.6	3.7													
				3.3	3.4	3.5	2.9			3.3	3.4	3.4	1.9						
					3.2	3.3	2.4				3.2	2.8	1.5						
							1.9												

Unit: ton

A= Boom length B= Working radius
E= Boom angle

[4.8m + 23m Luffing jib]
Performance B

A	14.2m							22.6m							31.0m							Unit: ton
	83	77	70	65	60	55	50	83	77	70	65	60	55	50	83	77	70	65	60	55	50	
E(°)																						
B(m)																						
10	80.0																					
12	70.9	80.0						63.5														
14	59.8	70.5						57.2							43.7							
16	51.6	59.5						51.4	59.8						43.7							
18	42.4	51.4	59.6					45.8	54.4						43.7	43.7						
20	33.4	44.9	52.2	50.3				40.2	49.2	46.2					39.4	43.7						
22	24.0	36.0	45.8	44.8				31.4	44.0	41.1					34.6	42.3						
24		26.5	40.0	40.2	38.7				38.0	36.9	34.2				27.9	38.0	33.0					
26			30.8	36.5	35.1	33.9			27.9	33.4	31.0					34.4	29.8					
28				30.1	32.1	30.9	29.8			30.5	28.3	26.2				28.8	27.2	24.3				
30						28.4	27.4				25.9	24.0					25.0	22.3				
32							25.3				23.9	22.1	20.4				23.0	20.5	18.1			
34												20.5	18.9	17.4				19.0	16.7			
36													17.5	16.2					15.5	13.6		
38														15.0					14.4	12.6		
40																			11.7	10.1		
42																						9.4

A= Boom length B= Working radius
E= Boom angle

[4.8m + 35m Luffing jib]
Performance B

A	14.2m							22.6m							31.0m							Unit: ton
	83	77	70	65	60	55	50	83	77	70	65	60	55	50	83	77	70	65	60	55	50	
E(°)																						
B(m)	16	51.6																				
	18	45.2	51.5				45.0															
	20	40.0	45.0				43.5								35.0							
	22	35.9	39.9				39.0	44.4							35.0							
	24	32.5	35.8	40.4			35.0	39.8							34.6							
	26	29.0	32.4	36.2			31.7	36.1	32.7						31.9	33.5						
	28	25.0	29.5	32.7	32.5		28.9	32.9	29.8						29.3	30.6						
	30	21.2	26.7	29.8	29.9		25.0	30.0	27.3						26.7	28.0	23.9					
	32	17.4	22.9	27.3	27.6	26.4	21.0	27.5	25.2	23.2					23.8	25.8	22.0					
	34	13.0	19.1	25.2	25.6	24.5	16.8	24.4	23.3	21.5					19.8	23.9	20.3					
	36		14.6	21.5	23.8	22.8	21.9	20.5	21.7	19.9	18.3				15.0	22.2	18.9	16.6				
	38			17.2	21.9	21.3	20.4	19.6	20.2	18.6	17.0					20.7	17.6	15.4				
	40				17.2	20.0	19.1	18.3	18.9	17.4	15.9	14.5				15.9	16.4	14.4	12.4			
	42						18.0	17.2		16.3	14.9	13.6					15.4	13.4	11.6			
	44							16.2		15.3	14.0	12.7	11.5				14.4	12.6	10.8			
	46										13.1	11.9	10.8					11.8	10.1	8.6		
	48											11.2	10.2						9.5	8.0		
	50												9.6						9.0	7.5		
	55																					4.8

A= Boom length B= Working radius
E= Boom angle

[4.8m + 35m Luffing jib]
Performance B

A	39.4m								47.8m					Unit: ton
	E (°)	83	77	70	65	60	55	50	83	77	70	65	60	
B (m)														
20	22.0													
22	22.0							13.0						
24	22.0							13.0						
26	22.0	22.0						13.0						
28	21.4	22.0						13.0	13.0					
30	19.6	22.0						13.0	13.0					
32	17.8	22.0						13.0	13.0					
34	16.0	20.5	18.3					13.0	13.0					
36	13.9	18.9	17.0					11.6	13.0					
38		17.2	15.8					10.0	13.0	12.9				
40		15.4	14.8	12.3					13.0	12.2				
42		13.2	13.8	11.5					11.8	11.7				
44			12.9	10.8					10.2	11.2	9.0			
46			12.1	10.1	8.1					10.7	8.4			
48				9.4	7.5					10.1	7.8			
50				8.9	6.9	4.7				9.5	7.3	4.7		
55							3.8	1.9					3.7	
60								1.3						

A= Boom length B= Working radius
E= Boom angle

[4.8m + 47m Luffing jib]
Performance B

A	14.2m						22.6m						31.0m						Unit: ton			
	83	77	70	65	60	55	50	83	77	70	65	60	55	50	83	77	70	65		60	55	50
E(°)																						
B(m)	18	31.0																				
	20	30.4					27.0															
	22	28.4	30.3				27.0								20.0							
	24	26.7	28.4				27.0								20.0							
	26	25.2	26.7				26.0	27.0							20.0							
	28	23.9	25.2				24.6	26.7							20.0							
	30	22.4	23.9	25.3			23.3	25.2							20.0	20.0						
	32	20.9	22.3	24.0			21.8	23.8							20.0	20.0						
	34	19.4	20.7	22.3	23.5		20.3	22.3	22.3						20.0	20.0						
	36	18.2	19.3	20.7	21.8		18.9	20.7	20.7						19.0	20.0						
	38	16.2	18.0	19.3	20.3		17.7	19.3	19.2	17.5					17.8	20.0	16.9					
	40	14.0	16.9	18.1	18.9	19.1	16.2	18.0	17.9	16.3					16.6	18.6	15.7					
	42	11.9	15.4	16.9	17.7	17.9	14.0	16.9	16.8	15.2					15.6	17.4	14.7	12.7				
	44	9.8	13.3	15.9	16.6	16.9	11.9	15.9	15.8	14.3	12.9				14.0	16.3	13.8	11.9				
	46	7.1	11.1	15.0	15.6	15.9	9.4	14.1	14.8	13.4	12.1				11.6	15.3	12.9	11.1				
	48		8.3	12.8	14.7	15.0		11.9	14.0	12.6	11.3	10.1			8.6	14.4	12.1	10.4	8.7			
	50			10.2	13.3	14.2		9.0	13.2	11.9	10.7	9.5				12.6	11.4	9.8	8.2			
	55									10.4	9.2	8.2	7.2				9.9	8.4	6.9	5.3		
	60											7.1	6.2					5.9	4.3			
	65																					2.8
																						2.1

A= Boom length B= Working radius
E= Boom angle

[4.8m + 47m Luffing jib]
Performance B

A	39.4m					47.8m				Unit: ton	
	E (°)	B (m)	83	77	70	65	60	83	77		70
24		14.5									
26		14.5						9.5			
28		14.5						9.5			
30		14.5						9.5			
32		14.5	14.5					9.5			
34		14.5	14.5					9.5	9.5		
36		14.5	14.5					9.5	9.5		
38		14.5	14.5					9.5	9.5		
40		13.4	14.5					9.5	9.5		
42		12.3	14.5	12.7				9.5	9.5		
44		11.1	14.2	11.9				8.6	9.5	9.3	
46		9.9	13.1	11.1				7.7	9.5	8.8	
48		8.5	12.0	10.4	8.4			6.8	9.5	8.4	
50			10.9	9.8	7.8			5.7	8.8	8.1	5.9
55				8.4	6.6	4.4			6.5	7.2	4.7
60					5.5	3.5				6.1	3.8
65						2.7					3.0

A= Boom length B= Working radius
E= Boom angle

[4.8m + 47m Luffing jib + 18m Extension jib]
Performance B

A	31.0m						39.4m						47.8m						Unit:ton
	83	77	70	65	60	55	83	77	70	65	60	83	77	70	65	60			
E(°)																			
B(m)	8.0						6.5												
30																			
35	8.0						6.5					4.5							
40	7.4	7.6					6.5	6.5				4.5							
45	6.9	7.1					6.5	6.5				4.5	4.5						
50	6.5	6.6	6.8				6.5	6.5				4.5	4.5						
55	6.0	6.2	6.4	6.5			6.1	6.3	6.5			4.5	4.5	4.5					
60	5.6	5.8	6.0	6.1			5.7	6.0	6.1	5.6		4.5	4.5	4.5					
65	5.4	5.5	5.7	5.8	5.0		5.4	5.6	5.8	4.6		4.1	4.5	4.5	3.0				
70		5.3	5.4	5.5	4.2	2.8		5.3	5.5	3.9	2.1		4.5	4.4	2.3				
75				4.9	3.5	2.2			4.9	3.2	1.6			3.7	1.8				
80					2.9	1.7				2.6	1.1			3.1	1.3				

A= Boom length B= Working radius

E= Boom angle

[4.8m + 47m Luffing jib + 23m Extension jib]
Performance B

A	31.0m						39.4m				47.8m			Unit : ton
	83	77	70	65	60	55	83	77	70	65	83	77	70	
E(°)														
B(m)														
30	5.0													
35	5.0						5.0							
40	5.0	5.0					5.0				3.5			
45	5.0	5.0					5.0	5.0			3.5	3.5		
50	4.6	4.9					4.7	5.0			3.5	3.5		
55	4.2	4.5	4.8				4.3	4.6	5.0		3.5	3.5		
60	3.9	4.1	4.3	4.5			3.9	4.2	4.5		3.5	3.5	3.5	
65	3.6	3.8	4.0	4.1			3.6	3.9	4.1	4.4	3.5	3.5	3.5	
70	3.4	3.5	3.7	3.8	3.9		3.4	3.6	3.8	3.7	3.4	3.5	3.5	
75		3.3	3.4	3.5	3.4	2.1		3.4	3.5	3.0		3.4	3.5	
80				3.3	2.8	1.5			3.3	2.5				2.9
85					2.2	1.1				1.9				2.4

A= Boom length B= Working radius
E= Boom angle

WORKING RADIUS - LIFTING HEIGHT

[4.8m + 17m Luffing jib]

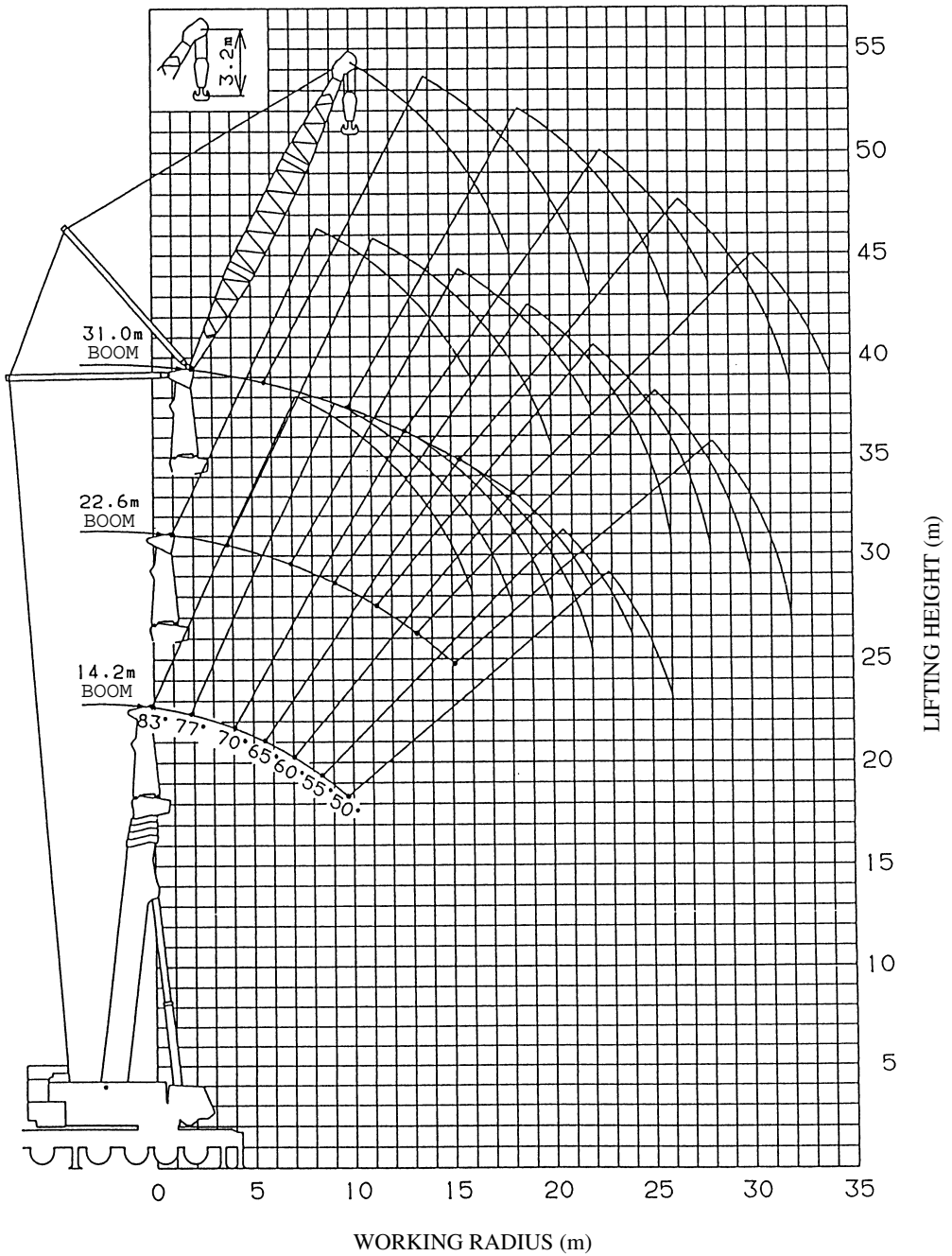

NOTES:

1. The deflection of the boom is not incorporated in the figure above.
2. The above chart is for Performance S.

[4.8m + 23m Luffing jib]

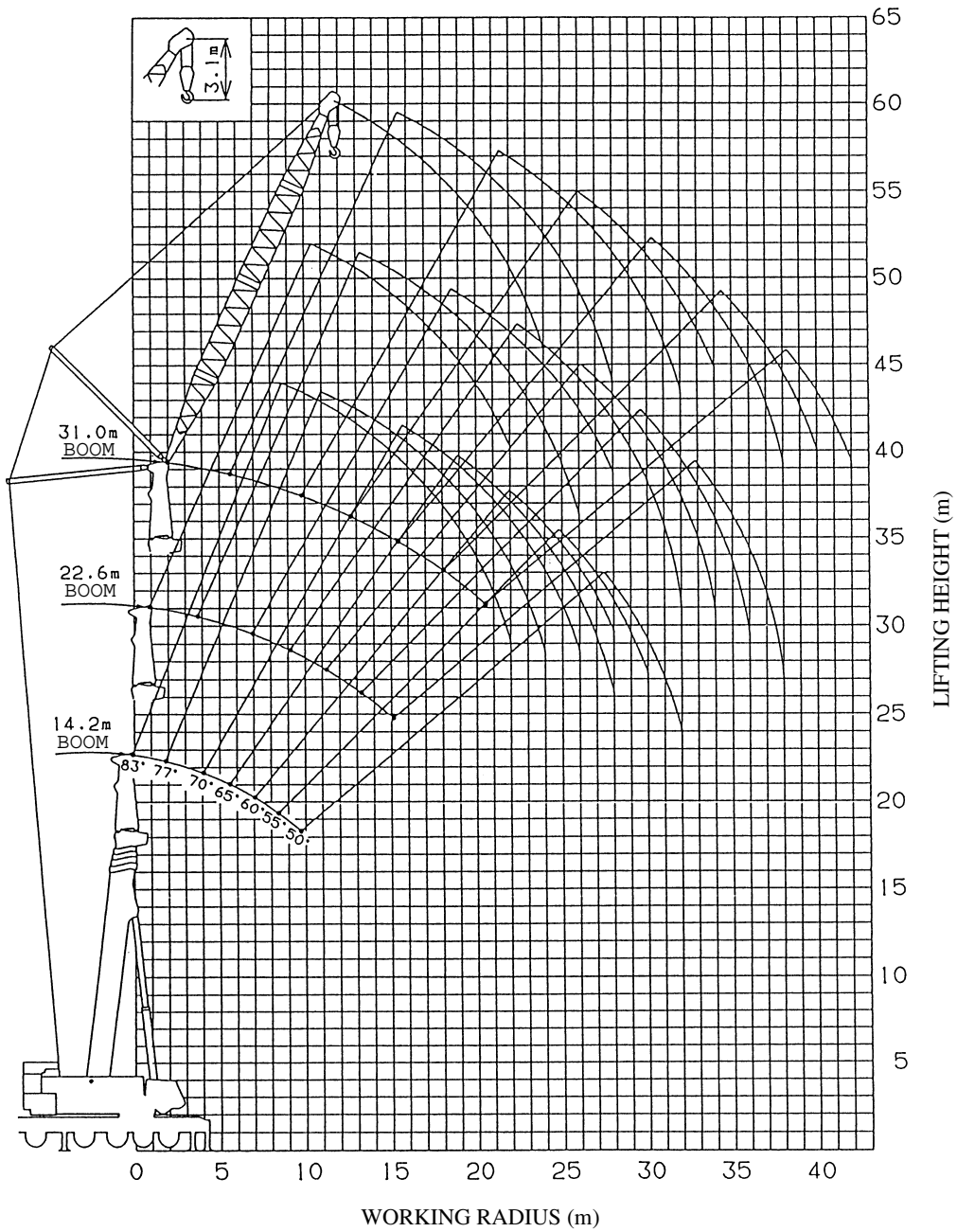

NOTES:

1. The deflection of the boom is not incorporated in the figure above.
2. The above chart is for Performance S.

[4.8m + 35m Luffing jib]

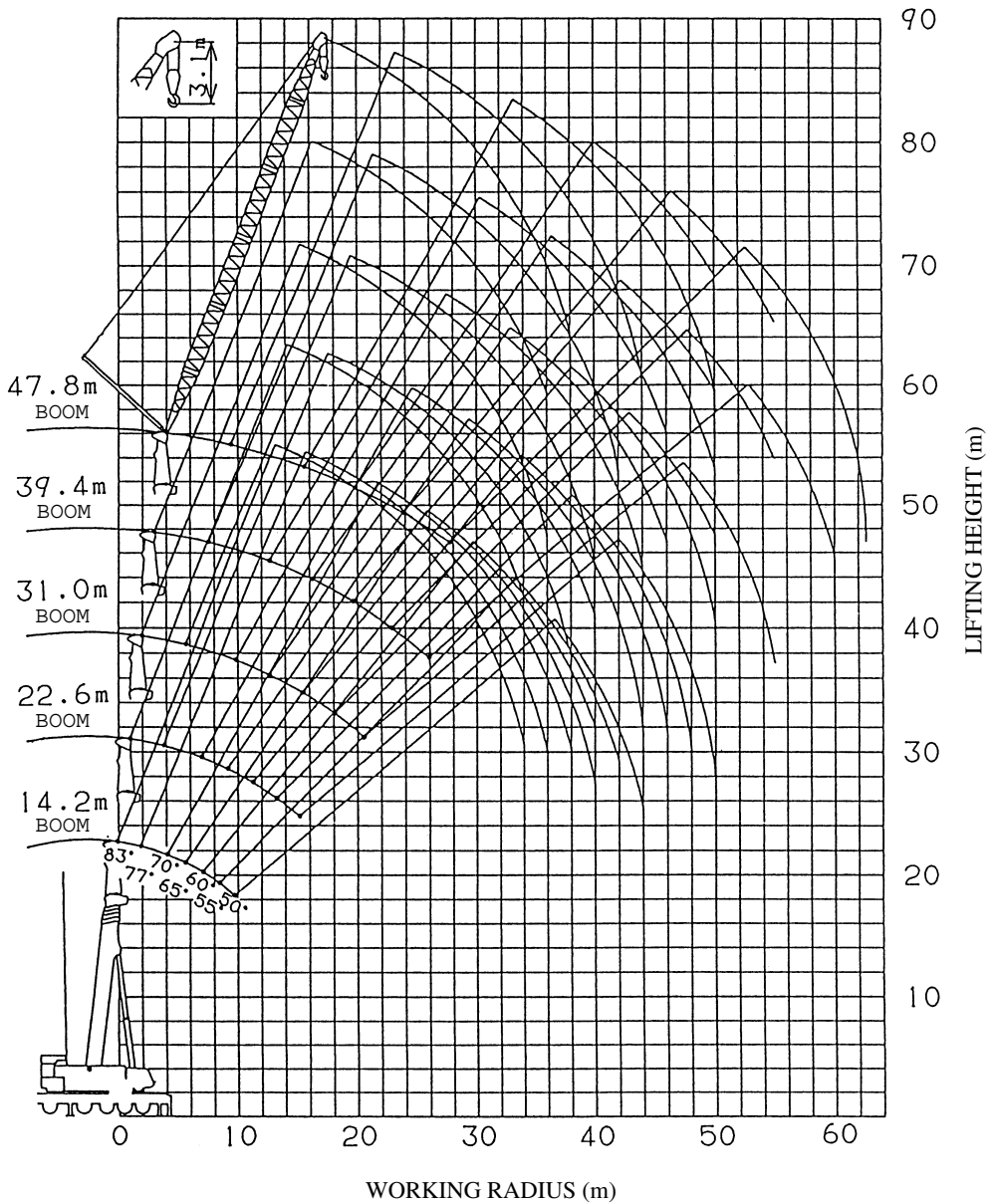

NOTES:

1. The deflection of the boom is not incorporated in the figure above.
2. The above chart is for Performance S.

[4.8m + 47m Luffing jib]

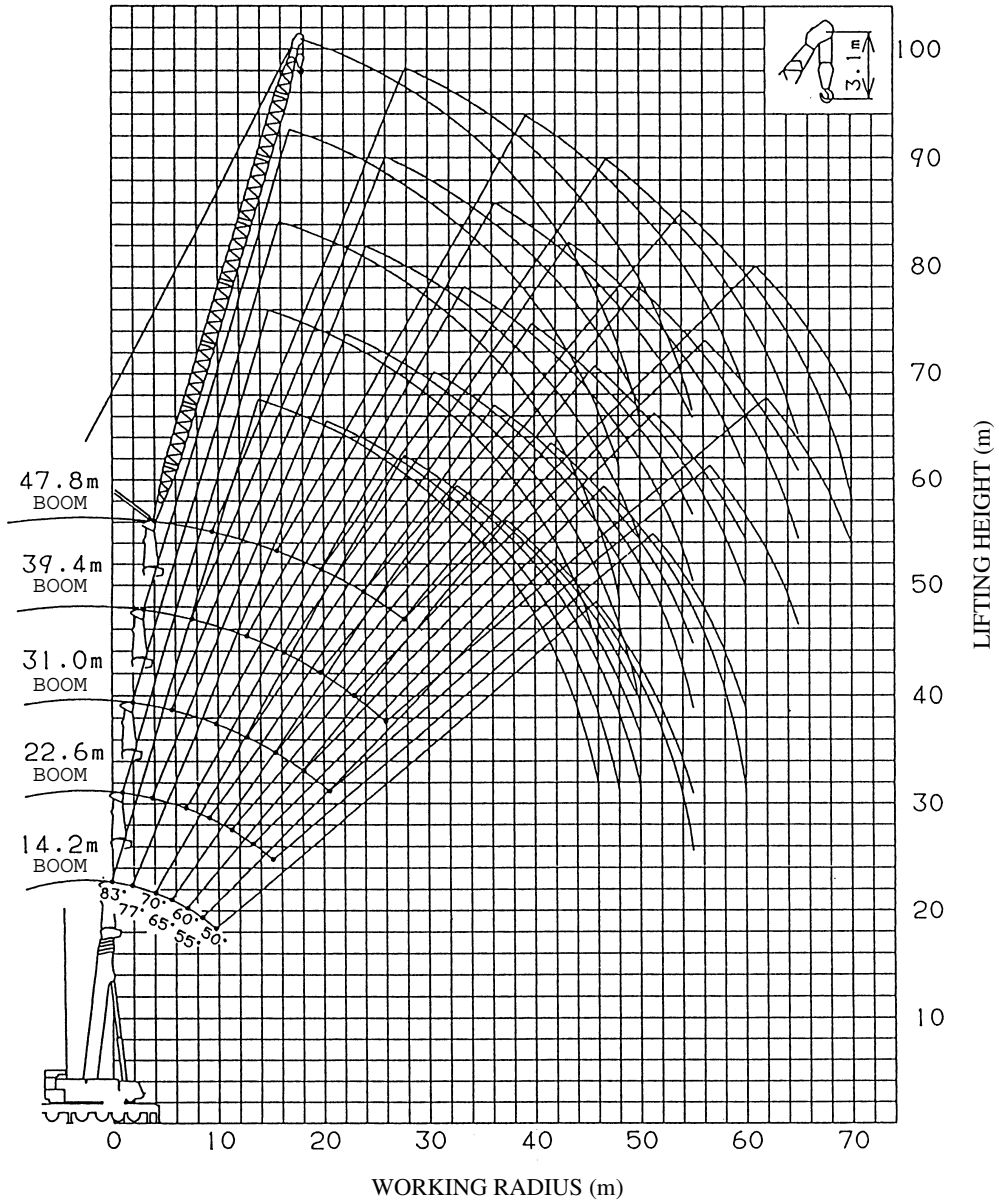

NOTES:

1. The deflection of the boom is not incorporated in the figure above.
2. The above chart is for Performance S.

[4.8m + 47m Luffing jib + 18m Extension jib]

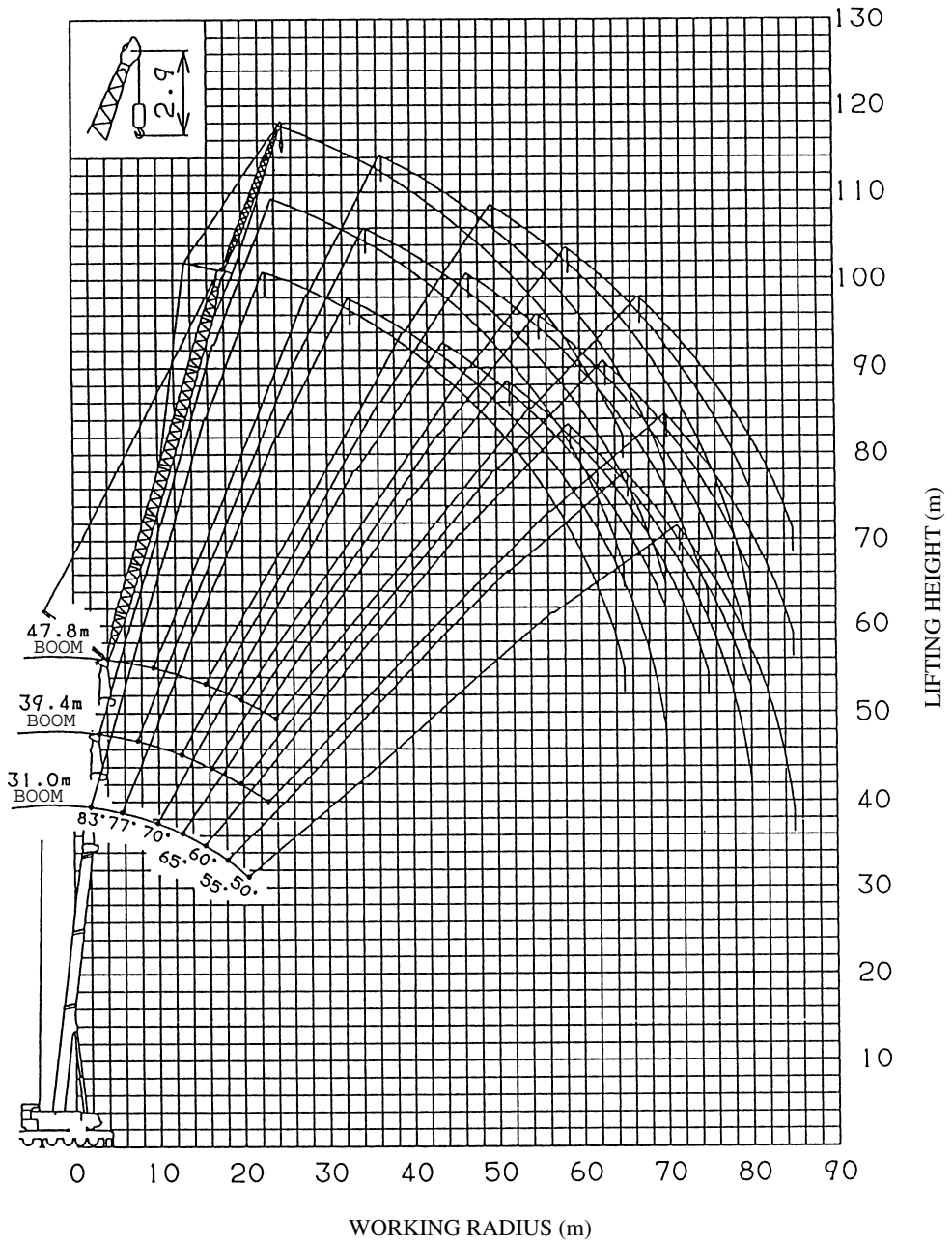

NOTES:

1. The deflection of the boom is not incorporated in the figure above.
2. The above chart is for Performance S.

[4.8m + 47m Luffing jib + 23m Extension jib]

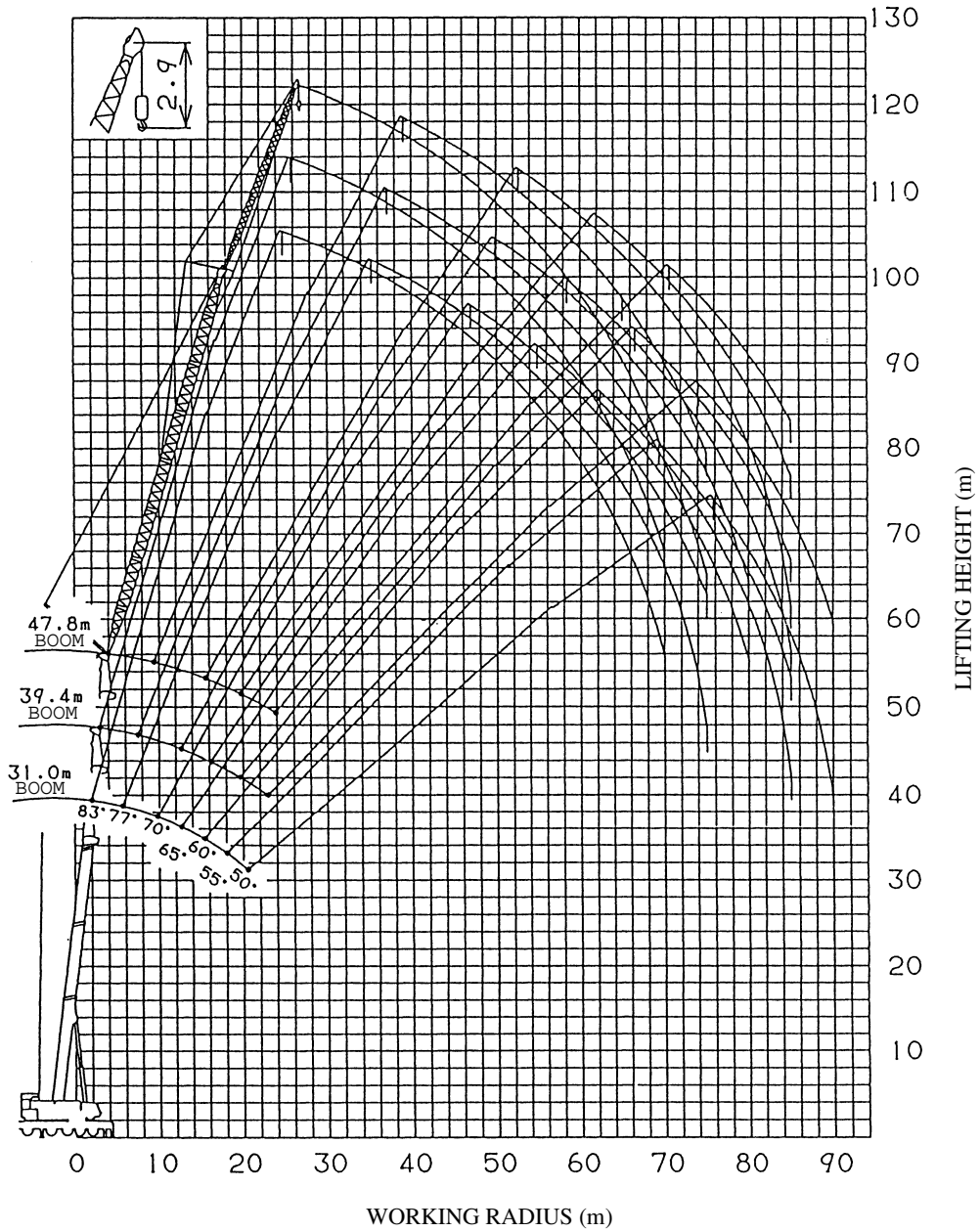

NOTES:

1. The deflection of the boom is not incorporated in the figure above.
2. The above chart is for Performance S.