



# KRUPP

**275 ton Capacity  
All-Terrain-Crane**



# KMK 6275

# Dimensions

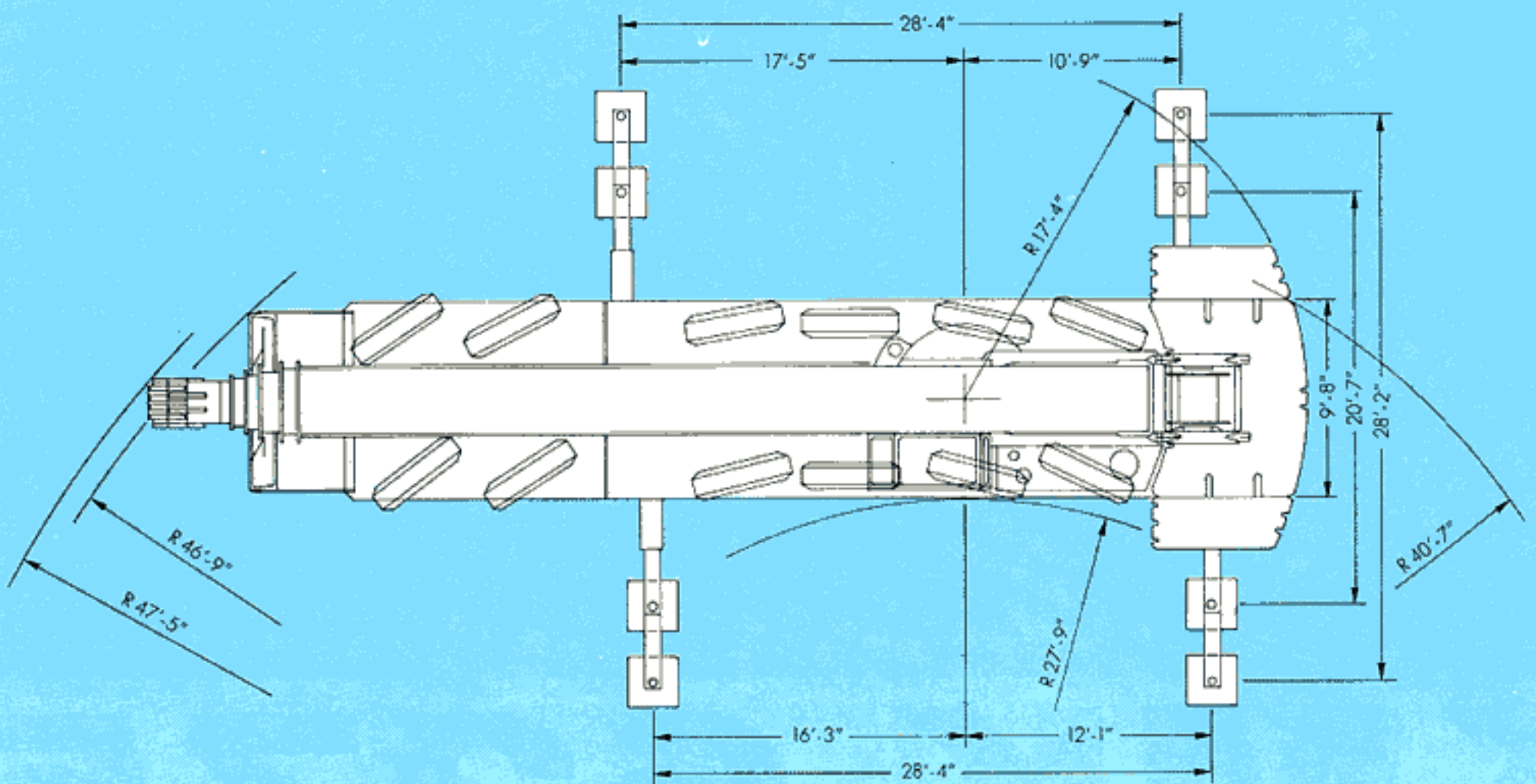
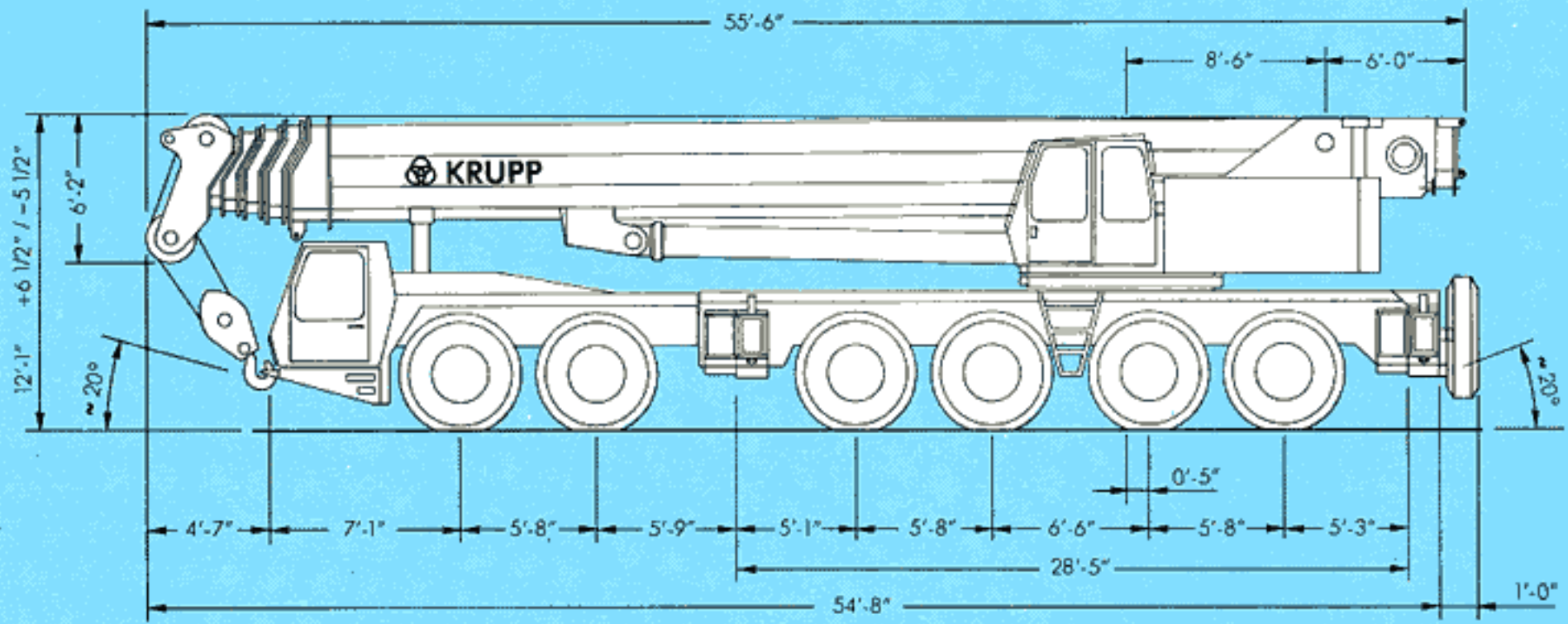

# Hook elevation diagram

Main boom



49-174 ft



360°

132\*

197

180

164

148

131

115

98

82

66

49

33

H (ft)

164

148

131

115

98

82

66

49

33



R (ft)

16

33

49

66

82

98

115

131

148

164

\*1000 lbs

# Main boom

Lifting capacities in 1000 lbs



49 - 174 ft



360°

Counterweight **132,2\*** lbs

Radius ft	Boom length								
	49 ft*	49 ft	80 ft	112 ft	133 ft	142 ft	164 ft	174 ft	
9	550.0								
10	481.6	388.8							
15	373.9	307.5	272.0						
20	282.2	250.9	227.8	174.3					
25	224.9	211.1	195.2	151.0	125.2				
30	179.5	180.7	170.3	131.6	111.9	92.2			
35		154.6	151.6	116.0	100.3	92.2	75.2	59.4	
40			127.5	103.0	90.3	88.2	73.6	59.4	
45			108.6	92.5	81.6	80.7	68.6	58.4	
50			93.7	84.7	74.0	74.3	63.8	54.6	
55			81.7	78.7	67.5	68.6	59.3	51.1	
60			71.9	73.0	61.8	63.6	55.0	47.6	
65			63.6	67.8	56.8	59.1	51.0	44.4	
70				63.1	52.5	55.0	47.3	41.3	
75				56.6	49.7	51.3	43.8	38.5	
80				50.8	47.2	46.7	40.7	35.8	
85				45.7	45.0	43.0	37.8	33.3	
90				41.3	43.0	40.0	35.1	31.1	
95				37.4	41.2	36.3	32.8	29.1	
100					38.0	34.7	30.6	27.2	
105					34.8	33.2	28.8	25.6	
110					31.9	31.7	27.2	24.1	
115					29.4	29.8	24.8	22.8	
120						27.5	22.5	21.6	
125							20.4	20.4	
130								18.5	
135								16.7	
140								15.1	
145								13.4	
150								11.8	
155								10.3	
 %	T1	0	0	50	100	100	100	100	100
	T2	0	0	50	100	100	100	100	100
	T3	0	0	0	0	70	100	100	100
	T4	0	0	0	0	0	0	70	100

Counterweight **88,2\*** lbs

Radius ft	Boom length						
	49 ft	80 ft	112 ft	133 ft	142 ft	164 ft	174 ft
10	382.3						
15	302.2	272.0					
20	246.5	227.8	174.3				
25	207.4	195.2	151.0	125.2			
30	165.4	162.6	131.6	111.9	92.2		
35	135.0	132.3	116.0	100.3	92.2	75.2	59.4
40		109.9	103.0	90.3	88.2	73.6	59.4
45		93.1	92.1	81.6	80.7	68.6	58.4
50		76.8	84.7	74.0	74.3	63.8	54.6
55		63.8	73.0	66.5	67.7	59.3	51.1
60		53.7	62.1	59.2	60.3	55.0	47.6
65		45.3	53.5	55.7	51.9	51.0	44.4
70			46.4	51.4	45.3	45.6	41.3
75			40.5	45.2	43.3	39.7	38.5
80			35.5	40.1	40.3	34.7	34.9
85			31.2	35.7	35.9	30.4	30.6
90			27.5	31.9	32.2	26.8	26.9
95			24.3	28.6	28.9	23.5	23.6
100				25.7	26.0	20.7	20.8
105				23.1	23.4	18.2	18.3
110				20.8	21.1	16.0	16.0
115				18.7	19.1	14.0	14.0
120					17.2	12.1	12.2
125						10.5	10.5
130						9.0	9.0
135						7.6	7.6
140						6.3	6.3
145							5.1
150							3.8
155							2.6

\*over rear only, 28'4" x 20'8" outrigger base

\*1000 lbs

# Hook elevation diagram

Lattice extension

49-174 ft      33-125 ft      360°      **132°**

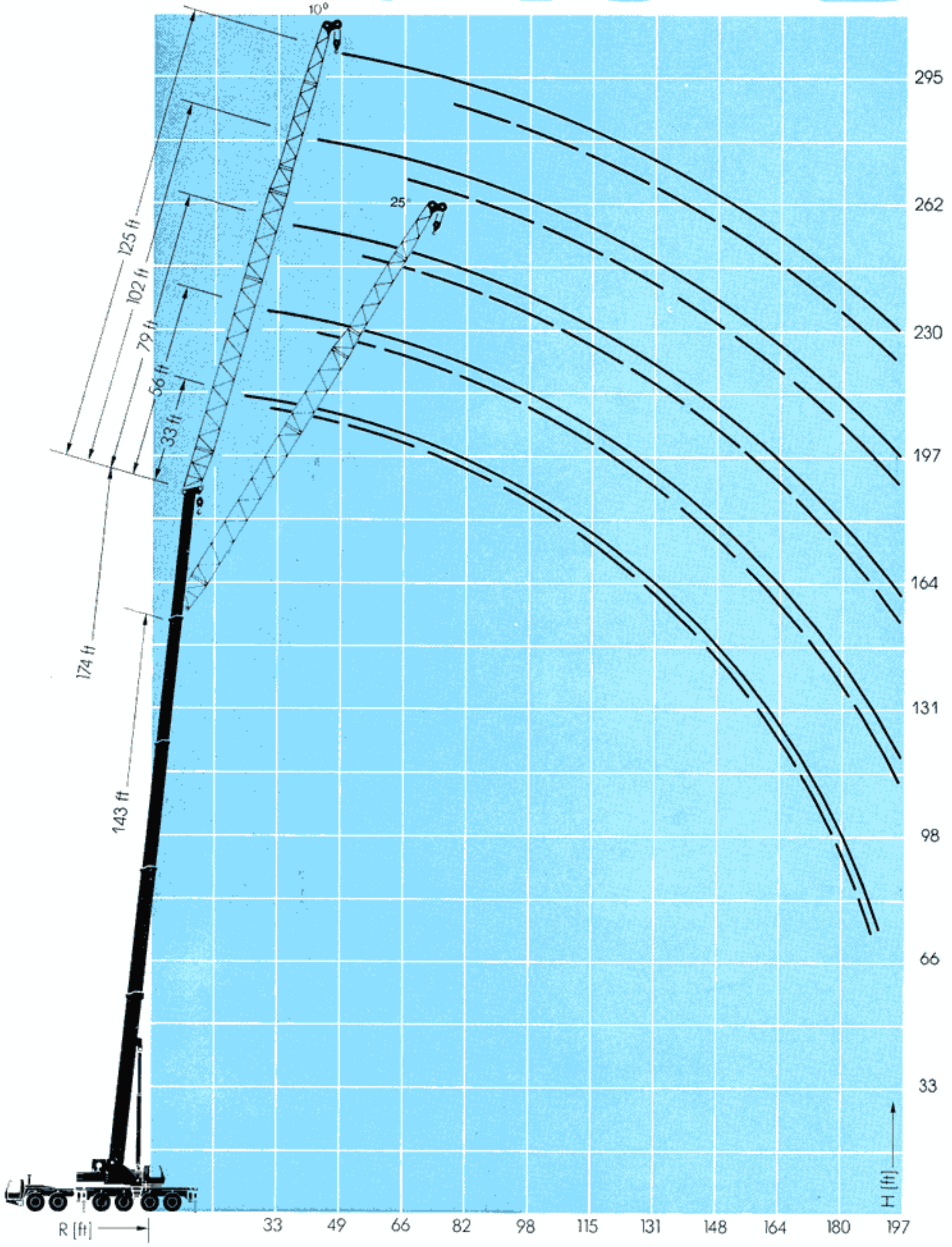

\* 1000 lbs

# Main boom + lattice extension (10° off-set)

Lifting capacities in 1000 lbs



33-125 ft



360°

Counterweight **132,2\*** lbs

Radius ft	Main boom 174 ft					Radius ft		
	33 ft	56 ft	79 ft	102 ft	125 ft			
40	28.7					40		
45	27.3					45		
50	26.0	20.8				50		
55	24.9	19.8	16.2			55		
60	23.8	19.0	15.5	12.7		60		
65	22.8	18.2	14.9	12.2		65		
70	22.0	17.5	14.3	11.6		70		
75	21.2	16.8	13.7	11.1	9.0	75		
80	20.4	16.2	13.2	10.7	8.7	80		
85	19.8	15.7	12.7	10.2	8.4	85		
90	19.1	15.1	12.2	9.8	8.1	90		
95	18.6	14.7	11.7	9.4	7.8	95		
100	18.0	14.2	11.3	9.1	7.5	100		
105	17.5	13.8	10.8	8.7	7.2	105		
110	17.0	13.4	10.4	8.4	6.9	110		
115	16.5	13.0	10.1	8.1	6.7	115		
120	16.1	12.6	9.7	7.8	6.4	120		
125	15.6	12.3	9.4	7.5	6.2	125		
130	15.2	12.0	9.0	7.3	5.9	130		
135	14.8	11.6	8.7	7.0	5.7	135		
140	14.4	11.3	8.5	6.8	5.5	140		
145	14.0	11.0	8.2	6.6	5.3	145		
150	13.2	10.7	8.0	6.4	5.1	150		
160	10.3	10.2	7.5	6.0	4.7	160		
170	7.7	9.1	7.2	5.6	4.4	170		
180	5.4	6.8	6.9	5.3	4.0	180		
190	3.4	4.8	6.3	5.0	3.7	190		
200			4.5	4.7	3.5	200		
210				3.3	3.2	210		
 %	T1	100	100	100	100	T1	 %	
	T2	100	100	100	100	100		T2
	T3	100	100	100	100	100		T3
	T4	100	100	100	100	100		T4

Counterweight **88,2\*** lbs

Radius ft	Main boom 174 ft					Radius ft		
	33 ft	56 ft	79 ft	102 ft	125 ft			
40	28.7					40		
45	27.3					45		
50	26.0	20.8				50		
55	24.9	19.8	16.2			55		
60	23.8	19.0	15.5	12.7		60		
65	22.8	18.2	14.9	12.2		65		
70	22.0	17.5	14.3	11.6		70		
75	21.2	16.8	13.7	11.1	9.0	75		
80	20.4	16.2	13.2	10.7	8.7	80		
85	19.8	15.7	12.7	10.2	8.4	85		
90	19.1	15.1	12.2	9.8	8.1	90		
95	18.6	14.7	11.7	9.4	7.8	95		
100	18.0	14.2	11.3	9.1	7.5	100		
105	17.5	13.8	10.8	8.7	7.2	105		
110	17.0	13.4	10.4	8.4	6.9	110		
115	15.9	13.0	10.1	8.1	6.7	115		
120	14.0	12.6	9.7	7.8	6.4	120		
125	12.3	12.3	9.4	7.5	6.2	125		
130	10.7	12.0	9.0	7.3	5.9	130		
135	9.3	10.5	8.7	7.0	5.7	135		
140	8.0	9.2	8.5	6.8	5.5	140		
145	6.7	8.0	8.2	6.6	5.3	145		
150	5.6	6.8	8.0	6.4	5.1	150		
160	3.4	4.8	6.1	6.0	4.7	160		
170			4.2	4.7	4.4	170		
180					3.3	180		
 %	T1	100	100	100	100	T1	 %	
	T2	100	100	100	100	100		T2
	T3	100	100	100	100	100		T3
	T4	100	100	100	100	100		T4

\*1000 lbs

# Main boom + lattice extension (25° off-set)

Lifting capacities in 1000 lbs



33–125 ft



360°

Counterweight **132,2\*** lbs

Radius ft	Main boom 143 ft					Radius ft		
	33 ft	56 ft	79 ft	102 ft	125 ft			
40	30.9					40		
45	29.6					45		
50	28.4					50		
55	27.4	22.1				55		
60	26.3	21.2				60		
65	25.4	20.4				65		
70	24.6	19.7	14.7			70		
75	23.8	19.1	14.3			75		
80	23.1	18.5	13.9	10.1		80		
85	22.4	18.0	13.5	9.8		85		
90	21.8	17.5	13.2	9.4		90		
95	21.2	17.0	12.8	9.2	7.1	95		
100	20.7	16.6	12.5	8.9	6.9	100		
105	20.2	16.2	12.2	8.7	6.7	105		
110	19.8	15.8	11.9	8.4	6.5	110		
115	19.4	15.5	11.6	8.2	6.4	115		
120	19.0	15.2	11.4	8.1	6.2	120		
125	18.6	14.8	11.2	7.9	6.0	125		
130	18.2	14.5	11.0	7.8	5.9	130		
135	16.2	14.2	10.8	7.6	5.7	135		
140	14.2	13.9	10.6	7.5	5.6	140		
145	12.2	13.7	10.5	7.4	5.4	145		
150	10.4	13.4	10.3	7.3	5.3	150		
155	8.6	12.4	10.2	7.2	5.2	155		
160		10.7	10.1	7.1	5.1	160		
165		9.1	10.0	7.0	5.0	165		
170		7.6	9.9	7.0	4.9	170		
175		6.2	9.8	6.9	4.8	175		
180		4.7	8.4	6.9	4.7	180		
185			7.1	6.8	4.6	185		
190			5.8	6.8	4.6	190		
195			4.6	6.7	4.5	195		
200			3.3	5.9	4.4	200		
205				4.7	4.4	205		
210				3.7	4.4	210		
215					4.3	215		
220					3.7	220		
 %	T1	100	100	100	100	100	T1	 %
	T2	100	100	100	100	100	T2	
	T3	100	100	100	100	100	T3	
	T4	0	0	0	0	0	T4	

\*1000 lbs

## Notes for lifting capacities

Rated loads do not exceed 85% of tipping load with the machine properly levelled on firm ground.

360° duties – on outriggers fully extended.

Note counterweight required as listed in relevant lifting capacity columns.

For safe crane operation due allowance must be made to compensate for high winds, side load, pendulum action and other hazardous conditions. No side pull permitted.

Hook blocks, slings and/or boom attachments are considered part of load, and their weight must be deducted from the rated lifting capacity to determine the net load.

Boom must be extended in accordance with sequence as noted on lifting capacity chart.

Consult crane manual to determine weight reduction for load handling devices and boom attachments.

Operate crane strictly in compliance with operator's manual.

# Main boom + lattice extension (25° off-set)

Lifting capacities in 1000 lbs



33-125 ft



360°

Counterweight **88,2\*** lbs

Radius		Main boom 143 ft					Radius	
ft		33 ft	56 ft	79 ft	102 ft	125 ft	ft	
40		30.9						40
45		29.6						45
50		28.4						50
55		27.4	22.1					55
60		26.3	21.2					60
65		25.4	20.4					65
70		24.6	19.7	14.7				70
75		23.8	19.1	14.3				75
80		23.1	18.5	13.9	10.1			80
85		22.4	18.0	13.5	9.8			85
90		21.8	17.5	13.2	9.4			90
95		21.2	17.0	12.8	9.2	7.1		95
100		20.7	16.6	12.5	8.9	6.9		100
105		19.6	16.2	12.2	8.7	6.7		105
110		17.1	15.8	11.9	8.4	6.5		110
115		14.8	15.5	11.6	8.2	6.4		115
120		12.7	15.2	11.4	8.1	6.2		120
125		10.8	14.3	11.2	7.9	6.0		125
130		9.1	12.5	11.0	7.8	5.9		130
135		7.5	10.8	10.8	7.6	5.7		135
140		6.1	9.3	10.6	7.5	5.6		140
145		4.5	7.8	10.5	7.4	5.4		145
150		3.0	6.5	9.5	7.3	5.3		150
155			5.2	8.2	7.2	5.2		155
160			3.8	7.0	7.1	5.1		160
165				5.8	7.0	5.0		165
170				4.8	6.7	4.9		170
175				3.5	5.7	4.8		175
180				2.3	4.7	4.7		180
185					3.5	4.6		185
190						4.5		190
195						3.4		195
 %	T1	100	100	100	100	100	T1	 %
	T2	100	100	100	100	100	T2	
	T3	100	100	100	100	100	T3	
	T4	0	0	0	0	0	T4	

\*1000 lbs



# Hook elevation diagram

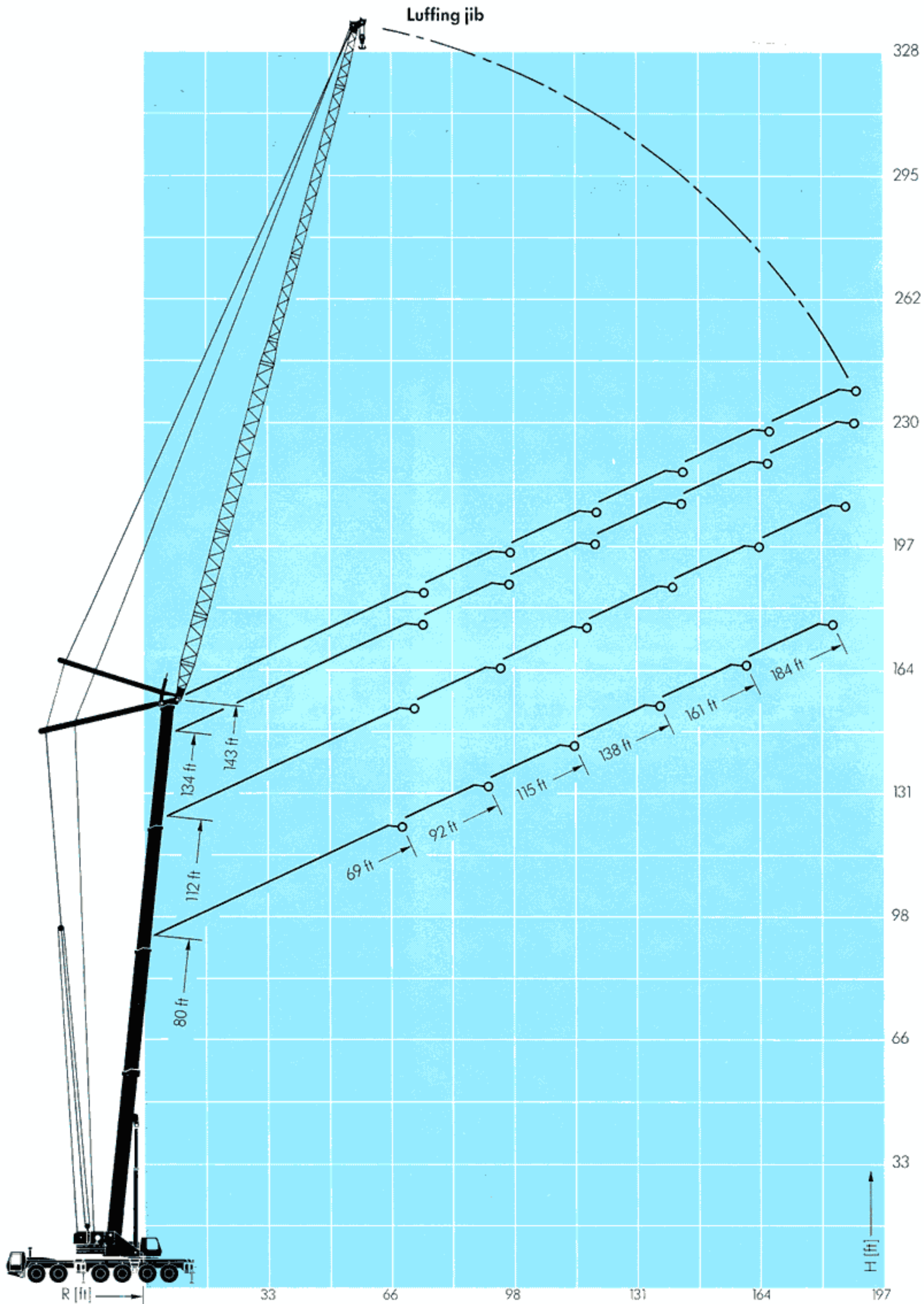

# Main boom + luffing jib

Lifting capacities in 1000 lbs  
Main boom at 75°





80 ft      360°      **88.2\*** lbs

Radius	Fly jib length						Radius		
	69 ft	92 ft	115 ft	138 ft	161 ft	184 ft			
60	66.1						60		
65	59.1	57.3					65		
70	53.2	53.0					70		
75	48.1	48.5					75		
80	43.8	44.3	41.4				80		
85	40.1	40.6	39.6	32.0			85		
90		37.5	36.6	32.0			90		
95		34.8	33.9	31.7			95		
100		32.4	31.5	30.6	24.3		100		
105		30.2	29.3	28.4	24.3		105		
110			27.5	26.6	24.3		110		
115			25.9	25.0	23.7	17.6	115		
120			24.3	23.5	22.6	17.6	120		
125			22.9	22.0	21.1	17.6	125		
130			21.7	20.8	19.9	17.6	130		
140				18.5	17.6	16.5	140		
150				16.5	15.6	14.5	150		
160					13.9	12.8	160		
170					12.4	11.3	170		
180						10.1	180		
190						8.9	190		
200							200		
210							210		
%	T1	50	50	50	50	50	50	T1	%
	T2	50	50	50	50	50	50	T2	
	T3	0	0	0	0	0	0	T3	
	T4	0	0	0	0	0	0	T4	





112 ft      360°      **88.2\*** lbs

Radius	Fly jib length						Radius		
	69 ft	92 ft	115 ft	138 ft	161 ft	184 ft			
60							60		
65							65		
70							70		
75	41.7						75		
80	37.8						80		
85	34.8	34.6					85		
90	32.1	32.1					90		
95		29.7					95		
100		27.6	26.6				100		
105		25.8	24.9	23.8			105		
110		24.3	23.2	22.1			110		
115		22.8	21.8	20.7			115		
120			20.5	19.4	17.8		120		
125			19.3	18.2	17.1	13.9	125		
130			18.1	17.0	15.9	13.9	130		
140				15.2	14.0	12.9	140		
150				13.4	12.3	11.2	150		
160				12.0	10.9	9.8	160		
170					9.6	8.5	170		
180					8.4	7.4	180		
190						6.4	190		
200						5.5	200		
210						4.6	210		
%	T1	100	100	100	100	100	100	T1	%
	T2	100	100	100	100	100	100	T2	
	T3	0	0	0	0	0	0	T3	
	T4	0	0	0	0	0	0	T4	





134 ft      360°      **88.2\*** lbs

Radius	Fly jib length						Radius		
	69 ft	92 ft	115 ft	138 ft	161 ft	184 ft			
60							60		
65							65		
70							70		
75							75		
80	29.9						80		
85	28.5						85		
90	27.2						90		
95	25.8	23.7					95		
100		22.9					100		
105		22.0	18.5				105		
110		21.2	18.0				110		
115		20.4	17.5				115		
120		19.4	17.0	13.8			120		
125		18.2	16.5	13.4			125		
130			16.0	12.9			130		
140			14.4	12.0	10.0	7.2	140		
150				11.3	9.3	6.9	150		
160				10.5	8.6	6.5	160		
170				9.1	8.0	6.0	170		
180					7.0	5.6	180		
190					6.2	5.1	190		
200							200		
210							210		
%	T1	100	100	100	100	100	100	T1	%
	T2	100	100	100	100	100	100	T2	
	T3	70	70	70	70	70	70	T3	
	T4	0	0	0	0	0	0	T4	





143 ft      360°      **88.2\*** lbs

Radius	Fly jib length						Radius		
	69 ft	92 ft	115 ft	138 ft	161 ft	184 ft			
60							60		
65							65		
70							70		
75							75		
80							80		
85	22.9						85		
90	21.8						90		
95	21.0						95		
100	20.2	18.4					100		
105	19.4	17.9					105		
110		17.4					110		
115		16.8	13.8				115		
120		16.3	13.3				120		
125		15.8	13.0	10.3			125		
130			12.5	10.0			130		
140			11.5	9.3	7.4		140		
150			10.7	8.8	6.9	4.4	150		
160				8.4	6.3	4.2	160		
170				8.0	6.0	4.0	170		
180					5.6	3.6	180		
190					5.1	3.1	190		
200						2.7	200		
210						2.4	210		
%	T1	100	100	100	100	100	100	T1	%
	T2	100	100	100	100	100	100	T2	
	T3	100	100	100	100	100	100	T3	
	T4	0	0	0	0	0	0	T4	

\*1000 lbs



# Main boom + luffing jib

Lifting capacities in 1000 lbs

Main boom at 84°



80 ft



360°

**57.3\*** lbs

Radius	Fly jib length						Radius		
	69 ft	92 ft	115 ft	138 ft	161 ft	184 ft		ft	
35	87.0						35		
40	84.0	65.0					40		
45	81.0	64.8	49.0				45		
50	79.0	64.6	48.8				50		
55	72.0	63.5	48.7	36.0			55		
60	62.0	62.6	48.6	35.8	27.0		60		
65	55.0	55.0	48.5	35.7	27.0	19.8	65		
70	50.0	48.2	47.4	35.6	27.0	19.8	70		
75		45.8	45.2	35.5	27.0	19.8	75		
80		41.0	39.6	35.4	27.0	19.8	80		
85		38.3	37.4	35.3	27.0	19.8	85		
90			34.6	33.0	27.0	19.8	90		
95			32.1	30.8	27.0	19.8	95		
100			29.7	28.6	26.7	19.8	100		
105			27.7	27.1	26.2	19.8	105		
110			25.7	25.3	24.6	19.8	110		
115				23.8	22.7	19.8	115		
120				22.0	21.1	19.5	120		
125				20.9	19.0	19.1	125		
130				19.6	19.7	17.8	130		
140					16.5	15.6	140		
150					14.7	13.8	150		
160							160		
170							170		
%	T1	50	50	50	50	50	50	T1	%
	T2	50	50	50	50	50	50	T2	
	T3	0	0	0	0	0	0	T3	
	T4	0	0	0	0	0	0	T4	



112 ft



360°

**57.3\*** lbs

Radius	Fly jib length						Radius		
	69 ft	92 ft	115 ft	138 ft	161 ft	184 ft		ft	
35							35		
40	55.5						40		
45	54.5	43.8					45		
50	54.0	42.5					50		
55	53.0	41.2	32.0				55		
60	52.8	41.1	32.0	24.2			60		
65	51.9	41.0	32.0	24.2			65		
70	47.3	40.6	32.0	24.2	18.0		70		
75		40.3	32.0	24.2	18.0	13.9	75		
80		40.0	32.0	24.2	18.0	13.9	80		
85			32.0	24.2	18.0	13.9	85		
90			32.0	24.2	18.0	13.9	90		
95			31.2	24.2	18.0	13.9	95		
100			30.4	24.2	18.0	13.9	100		
105			27.7	24.2	18.0	13.9	105		
110				24.2	18.0	13.9	110		
115				23.1	18.0	13.9	115		
120				22.0	18.0	13.9	120		
125				20.9	18.0	13.9	125		
130					18.0	13.9	130		
140					17.0	13.9	140		
150						13.9	150		
160							160		
170							170		
%	T1	100	100	100	100	100	100	T1	%
	T2	100	100	100	100	100	100	T2	
	T3	0	0	0	0	0	0	T3	
	T4	0	0	0	0	0	0	T4	



134 ft



360°

**57.3\*** lbs

Radius	Fly jib length						Radius		
	69 ft	92 ft	115 ft	138 ft	161 ft	184 ft		ft	
35							35		
40	35.0						40		
45	35.0	26.0					45		
50	35.0	26.0					50		
55	35.0	26.0					55		
60	35.0	26.0	20.0				60		
65	35.0	26.0	20.0	15.4			65		
70	35.0	26.0	20.0	15.4	11.6		70		
75	35.0	26.0	20.0	15.4	11.6		75		
80		26.0	20.0	15.4	11.6	7.4	80		
85		26.0	20.0	15.4	11.6	7.4	85		
90		26.0	20.0	15.4	11.6	7.4	90		
95			20.0	15.4	11.6	7.4	95		
100			20.0	15.4	11.6	7.4	100		
105			20.0	15.4	11.6	7.4	105		
110			20.0	15.4	11.6	7.4	110		
115			20.0	15.4	11.6	7.4	115		
120				15.4	11.6	7.4	120		
125				15.4	11.6	7.4	125		
130				15.4	11.6	7.4	130		
140					11.6	7.4	140		
150					11.6	7.4	150		
160							160		
170							170		
%	T1	100	100	100	100	100	100	T1	%
	T2	100	100	100	100	100	100	T2	
	T3	70	70	70	70	70	70	T3	
	T4	0	0	0	0	0	0	T4	



143 ft



360°

**57.3\*** lbs

Radius	Fly jib length						Radius		
	69 ft	92 ft	115 ft	138 ft	161 ft	184 ft		ft	
35							35		
40							40		
45	28.0						45		
50	28.0						50		
55	28.0	22.0					55		
60	28.0	22.0	16.0	11.6			60		
65	28.0	22.0	16.0	11.6			65		
70	28.0	22.0	16.0	11.6			70		
75		22.0	16.0	11.6	8.1		75		
80		22.0	16.0	11.6	8.1	5.5	80		
85		22.0	16.0	11.6	8.1	5.5	85		
90		22.0	16.0	11.6	8.1	5.5	90		
95			16.0	11.6	8.1	5.5	95		
100			16.0	11.6	8.1	5.5	100		
105			16.0	11.6	8.1	5.5	105		
110			16.0	11.6	8.1	5.5	110		
115				11.6	8.1	5.5	115		
120				11.6	8.1	5.5	120		
125				11.6	8.1	5.5	125		
130				11.6	8.1	5.5	130		
140					8.1	5.5	140		
150					8.1	5.5	150		
160						5.5	160		
170						5.5	170		
%	T1	100	100	100	100	100	100	T1	%
	T2	100	100	100	100	100	100	T2	
	T3	100	100	100	100	100	100	T3	
	T4	0	0	0	0	0	0	T4	

# Weights / Working speeds



Axle	1	2	3	4	5	6	Total weight
1000 lbs	26,5	26,5	26,5	26,5	26,5	26,5	159,0



Lifting capacity	Sheaves	Parts of line	Weight lbs
150	7	2 - 15	5730
110	5	2 - 11	3300
70	3	1 - 7	2200
30	1	1 - 3	1320



Gear	1	2	3	4	5	R	Gradeability max.
On-road (mp/h)	8	13	21	30	42	9	
Off-road (mp/h)	4,5	7,5	12	17,5	24,5	5	47%
Tires	14.00 R 25						



Drives	ininitely variable	Rope diameter / Rope length	Max. single line pull
Main hoist	0-426 ft/min single line	24 mm (1") 1000 ft	21,600 lbs
Auxiliary hoist	0-426 ft/min single line	24 mm (1") 1100 ft	21,600 lbs
Swing gear	0 - 1,6 min <sup>-1</sup>		
Boom elevation	approx. 78 s from - 1,2° to + 85° boom angle		
Telescoping	approx. 165 s from 49 to 143 ft 340 s from 49 to 174 ft boom length		



## Carrier

<b>Chassis:</b>	Special KRUPP 6-axle carrier, all-welded torsion-resistant box-type construction in high strength steel.
<b>Outriggers:</b>	4 double hydraulically telescoping beams with vertical cylinders and outrigger pads. Independent horizontal and vertical movement control on each side of the chassis. Levelling device.
<b>Engine:</b>	Mercedes-Benz OM 444 A diesel, 12 cylinders, water-cooled, 405 kW (551 HP) at 2100 min <sup>-1</sup> (DIN 6271 IFN). Max. torque: 1100 Nm at 1000–1500 min <sup>-1</sup> . Tank capacity: approx. 125 gal.
<b>Transmission:</b>	Allison 5-speed automatic.
<b>Transfer case:</b>	Transfer case with 2 speeds and longitudinal differential lock.
<b>Axle lines:</b>	6 axle lines; 1st, 2nd, 3rd, 5th and 6th steering axle lines; 1st, 2nd, 4th and 5th driven axle lines.
<b>Suspension:</b>	All axle lines with hydropneumatic suspension and axle lock-out. Level regulation. Suspension range: + 6½"/– 5½". Possible combinations for transverse slope.
<b>Tires:</b>	12 tires 14.00 R 25.
<b>Steering:</b>	ZF dual-circuit hydraulic power assisted steering.
<b>Brakes:</b>	Service brake: pneumatic dual-circuit, acting on all wheels, air dryer. Permanent brake: hydraulic retarder integrated with Allison automatic transmission. Hand brake: pneumatically operated spring-loaded brake acting on 2nd, 4th, 5th and 6th axle line.
<b>Driver's cab:</b>	Aluminium, 2-man-design, safety glass, driver's seat with hydraulic suspension, engine hot-water heating. Complete instrumentation and driving controls.
<b>Electrical system:</b>	Three-phase generator 28 V/55 A, 2 batteries 12 V/170 Ah, lighting system and signals.

## Superstructure

<b>Frame:</b>	KRUPP-made, torsion-resistant welded construction in high strength steel.
<b>Engine:</b>	Mercedes-Benz OM 447 A diesel, 6 cylinders, water-cooled, 218 kW (296 HP) at 2100 min <sup>-1</sup> (DIN 6271 IFN). Max. torque 1226 Nm at 1100–1600 min <sup>-1</sup> . Tank capacity: 75 gal.
<b>Hydraulic system:</b>	4 separate circuits, 3 axial piston variable displacement pumps in open circuit with electronic engine speed related pump control and 1 axial piston variable displacement pump in closed circuit. Tank capacity: 500 gal hydraulic oil.
<b>Control system:</b>	Infinite variation of all crane movements by electrically, controlled hydraulic pilot circuit and control levers with automatic reset to zero.
<b>Main hoist:</b>	Axial-piston variable displacement motor with planetary gear and automatic brake.
<b>Boom elevation:</b>	1 cylinder with safety check valve, boom angle from – 1,2° to + 85°.
<b>Swing:</b>	2 axial piston fixed displacement motors, planetary gear, holding brake and service brake.
<b>Cab:</b>	Aluminium, full vision, safety glass, adjustable operator's seat with hydraulic suspension, engine hot-water-heating. Armrest integrated crane controls. Ergonomically arranged instrumentation and crane operating controls.
<b>Safety installations:</b>	Hoist and lowering limit switch, pipe burst safety valves, pressure relief valves.
<b>Telescopic boom:</b>	Welded construction in high strength steel, 1 base section, 4 telescopic sections. Total boom length: 174 ft, all-hydraulic extension under partial load.
<b>Electrical system:</b>	Three-phase generator 28 V/55 A, 2 batteries 12 V/143 Ah.

## Additional equipment



<b>Tires:</b>	12 tires 16.00 R25 / 20.5 R25.
<b>Boom extension:</b>	Lattice design, 33 - 125 ft, in sections of 23 ft.
<b>Luffing jib:</b>	Lattice design, 69 - 184 ft, in sections of 23 ft.
<b>Aux. hoist:</b>	2nd hoisting gear.
<b>Safe load indicator:</b>	Electronic load moment safety device (type EKS 83) with automatic cut-out and digital display for actual and admissible load, radius and various working conditions.
<b>Driver's cab:</b>	Engine-independent heater, also to be used as engine preheater.

**Further equipment upon request.**

**Subject to change without notice.**

# KRUPP Hydraulic Mobile Cranes

## Product Range

All-Terrain Cranes	Max. lifting capacity	Max. hook height
KMK 2025 	25 ton	121 ft
KMK 3045 	45 ton	150 ft
KMK 4065 	65 ton	170 ft
KMK 4080 	80 ton	180 ft
KMK 5110 	110 ton	190 ft
KMK 5125 	125 ton	216 ft
KMK 6190 	190 ton	260 ft
KMK 6275 	275 ton	330 ft
KMK 7300 	300 ton	380 ft
KMK 8500 	500 ton	390 ft

### USA

#### Krupp Industries Inc.

Construction  
Equipment Group  
210 Vandale Drive  
(Pittsburgh)  
Houston, PA 15342  
Telephone (412) 746-9360  
Telefax (412) 746-9350

Branch Office:  
240 N. Norwood  
Houston, TX 77011  
Telephone (713) 926-1100  
Telefax (713) 926-0989

### CANADA

#### Krupp Canada Inc.

98 rue Columbus  
Pointe Claire, Que. H9R 4K4  
Telephone (514) 694-4740  
Telefax (514) 694-6280

#### Krupp Canada Inc.

429 Dewitt Road, Unit 15  
Stoney Creek, Ont. L8E 4C3  
Telephone (416) 664-6592  
Telefax (416) 664-2789