

Model G5-18A

TELEHANDLER



Performance

Rated Capacity

At 24 in. (610 mm) load center,
5,500 lb (2,495 kg)

Maximum Lift Height

18 ft 4 in. (5.6 m)

Maximum Forward Reach

10 ft 11 in. (3.3 m)

Capacity at Maximum Lift Height

4,400 lb (1,996 kg)

Capacity at Maximum Forward Reach

1,850 lb (839 kg)

Lift Speed (boom retracted)

Up: 6.2 sec

Down: 4.3 sec

Boom Speed

Extend: 6.3 sec

Retract: 3.4 sec

Travel Speed Forward

17 mph (27 km/h)

Drawbar Pull

8,700 lb (3,946 kg)

Breakout Force

7,650 lb (3,470 kg)

Operating Weight

With 48 in. Carriage and Forks

10,800 lb (4,899 kg)

Standard Specifications

Engine

Make and Model	Perkins 1104D
Fuel	No. 2 Diesel
Cycles	4
No. of Cylinders	4
Displacement	268.4 cu in. (4.4 L)
Rated Speed	2,200 rpm
Max. Gross BHP	84 hp (63 kW)
Fuel Tank	24 gal (91 L)

Engine Filters

Two-stage dry air cleaner — centrifugal pre-cleaner with continuous dust ejector and replaceable dry filter element.

Visual service indicator.

Glow Plugs

Electrical System

Voltage: 12V

Alternator: 75 amp

Battery: 950 cold cranking amps at 0°F

Transmission

Hydrostatic

Axles

High bias limited slip differential on front axle.

Planetary on front and rear axle.

Service Brakes

Inboard wet disc brakes on front axle.

Parking Brakes

Wet disc spring-applied hydraulic release.

Light on dash indicates when brake is on.

Tires

Standard: 12 x 16.5

Cab

Certified ROPS/FOPS structure, adjustable suspension seat.

Steering 4-Wheel

Operator selectable 4-wheel circle, 4-wheel crab, 2-wheel front.

Instruments

Indicators for machine hours, fuel-level, steering pressure, alternator, pre-heat, coolant temperature, parking brake and oil pressure

Reverse motion alarm.

Panel and switches are illuminated for night operation

Controls

Grouped for operator comfort and convenience.

Single joystick proportional controls.

Hydraulic System-Implement

Single-section gear pump.

17 gal (64.4 L) system capacity.

10 micron filter with visual service indicator and suction strainer.

Lift, crowd, and tilt cylinders have holding valves intended to prevent dropping of load in the event of hose failure.

Auxiliary Hydraulic Circuit

Consists of valves, controls and hydraulic lines

Attachment Tilt

125 degrees

Accessories & Options

Enclosed Cab

Battery Disconnect Switch

Road Light Package

Work Light Package

Skylight/Rear Wiper Package

Radio Ready Kit (Enclosed Cab Only)

Molded Floor Mat

Tow Hitch w/trailer plug

Tow Hitch w/automatic pin & trailer plug

Fenders

Brick Guard

Air Conditioning

Block Heater

Tilt Steering

Hydraulic Quick Switch

Rear Auxiliary Hydraulics

Universal Skid Steer Coupler

Tire Options:

Foam-Filled — 14 x 17.5
12 x 16.5

Pneumatic — 14 x 17.5

Solid — 30 x 12



Attachments

Standard Carriage

50 in. (1.3 m)

Side Tilt Carriage

48 in. (1.2 m)

Pallet Forks

2 x 4 x 48 in. (51 mm x 102 mm x 1.2 m)

Lumber Forks

1.5 x 6 x 48 in. (38 mm x 152 mm x 1.2 m)

Cubing Forks

2 x 2 x 48 in. (51 mm x 51 mm x 1.2 m)

General Purpose Bucket

1.0 cu yd (0.76 m³) — 73 in. (1.85 m)

Light Material Bucket

1.7 cu yd (1.29 m³) — 72 in. (1.8 m)

Grapple Bucket

1.0 cu yd (0.76 m³) — 72 in. (1.8 m)

Lifting Hook

Universal Skid Steer Adapter

Model G5-18A

TELEHANDLER

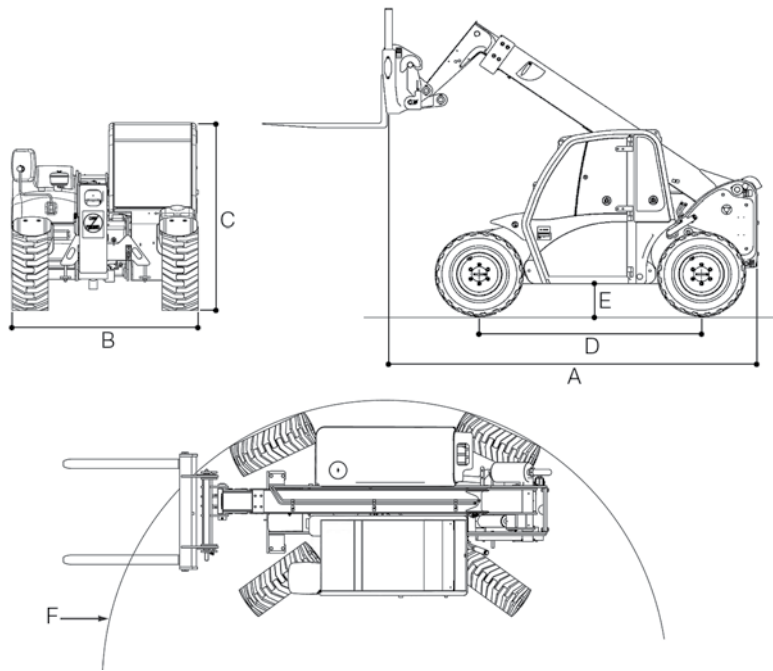

Dimensions

A. Length (less forks)	144.2 in. (3.7 m)
B. Width	71.5 in. (1.8 m)
C. Height	75.6 in. (1.9 m)
D. Wheelbase	90.0 in. (2.3 m)
E. Ground Clearance	10.8 in. (274 mm)
F. Outside Turning Radius	126.0 in. (3.2 m)

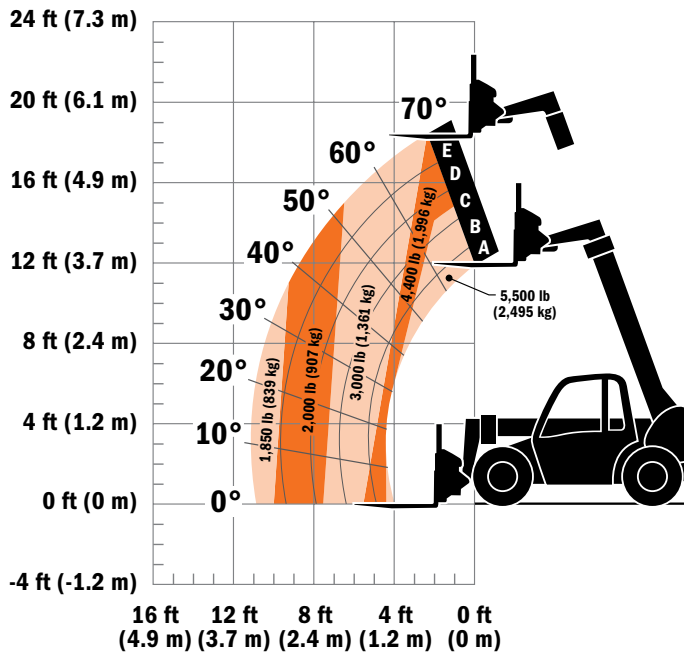

IMPORTANT

Rated lift capacities shown are with machine equipped with carriage and pallet forks. The machine must be level on a firm surface with undamaged, properly inflated tires. Machine specifications and stability are based on rated lift capacities at specific boom angles and boom lengths. (If specifications are critical, the proposed application should be discussed with your dealer.)

DO NOT exceed rated lift capacity loads, as unstable and dangerous machine conditions will result.

DO NOT tip the machine forward to determine the allowable load.

Use only JLG approved attachments with proper material handler model/attachment load capacity charts displayed in the operator's cab. OSHA requires all rough terrain forklift operators be trained according to OSHA 29 CFR 1910.178 (1).



JLG Industries, Inc.

1 JLG Drive
 McConnellsburg, PA 17233-9533
 Telephone 717-485-5161
 Toll-free in US 877-JLG-LIFT
 Fax 717-485-6417
www.jlg.com

An Oshkosh Corporation Company

Due to continuous product improvements, JLG Industries reserves the right to make specification and/or equipment changes without prior notification. This machine meets or exceeds ASME B56.6-1998 as originally manufactured for intended applications.

Form No.: G5-18A-1007
 Part No.: 3132221
 R061102
 Printed in USA