

10/65

Articulating Crane Technical Specifications

10/65 Lifting Capacities

10/65 - 1 Hydraulic

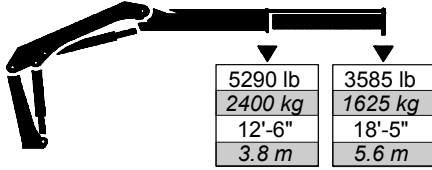

10/65 - 2 Hydraulic

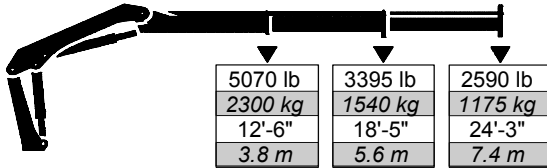

10/65 - 3 Hydraulic

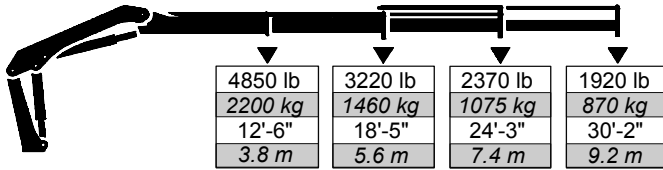

10/65 - 4 Hydraulic

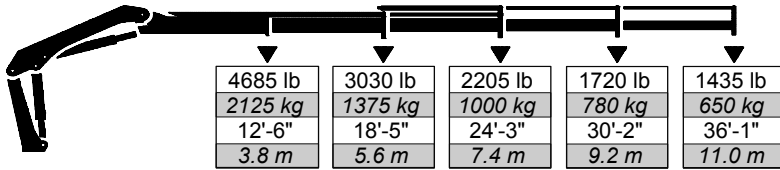

Note: Crane appearance subject to change.

10/65 Specifications

Outrigger Pad Diameter	6.3" (160 mm)
Crane Storage Height	7' 0" (2130 mm)
Mounting Space ***	2' 3" (680 mm)
Rotational Torque	10,055 ft-lb (1390 kg-m)
Rotation	400°
Optimum Pump Performance	9 gpm (35 lpm)
System Pressure	4640 psi (320 bar)
Oil Reservoir Capacity	11 gal (42 l)
Outrigger Extension Span	
Standard (manual out /hydraulic down)	15' 3" (4650 mm)
Weight	380 lb (173 kg)
Option (hydraulic out / hydraulic down)	18' 10" (5750 mm)
Weight	540 lb (245 kg)

Minimum Chassis Specifications

Front Axle Rating (GAWR)	9,000 lb (4080 kg)
Rear Axle Rating (GAWR)	17,000 lb (7710 kg)
Resistance To Bending Moment	960,000 in-lb (110,605 kg-m)

10/65	1 - Hydraulic	2 - Hydraulic	3 - Hydraulic	4 - Hydraulic
Crane Rating*	65,095 ft-lb (9.0 tm)	63,650 ft-lb (8.8 tm)	60,755 ft-lb (8.4 tm)	57,865 ft-lb (8.0 tm)
Maximum Horizontal Reach	18' 8" (5.7 m)	24' 11" (7.6 m)	30' 10" (9.4 m)	37' 1" (11.3 m)
Maximum Vertical Reach	25' 3" (7.7 m)	31' 2" (9.5 m)	36' 9" (11.2 m)	42' 8" (13.0 m)
Maximum Capacity	7165 lb (3250 kg)	6945 lb (3150 kg)	6770 lb (3070 kg)	6615 lb (3000 kg)
Max Cap @ Max Reach	3585 lb (1625 kg)	2590 lb (1175 kg)	1920 lb (870 kg)	1435 lb (650 kg)
Crane Weight **	2315 lb (1050 kg)	2515 lb (1140 kg)	2710 lb (1230 kg)	2890 lb (1310 kg)
Hook Approach				
Vertical	8' 10" (2.69 m)	8' 6" (2.60 m)	8' 3" (2.52 m)	8' 0" (2.44 m)
Horizontal	2' 9" (0.84 m)	2' 11" (0.89 m)	3' 1" (0.94 m)	3' 3" (1.0 m)
Center of Gravity - Stored				
Vertical	1' 10" (555 mm)	1' 10" (560 mm)	1' 10" (570 mm)	1' 11" (580 mm)
Horizontal (C/L RotTo Bridge)	6.7" (170 mm)	6.7" (170 mm)	6.7" (170 mm)	6.7" (170 mm)

* Crane rating (ft-lb) is the rated load (lb) multiplied by the respective distance (ft) from centerline of rotation with all extensions retracted and the inner and outer booms in a horizontal position, per ANSI B30.22. ** Crane weight does not include outriggers. *** Maximum swing clearance radius required is 23" (575 mm) at 7'-7" (2320 mm).

© 2009 Iowa Mold Tooling Co., Inc. All Rights Reserved.



An Oshkosh Corporation Company

10/65 Articulating Crane



An Oshkosh Corporation Company

Geometric Configurations

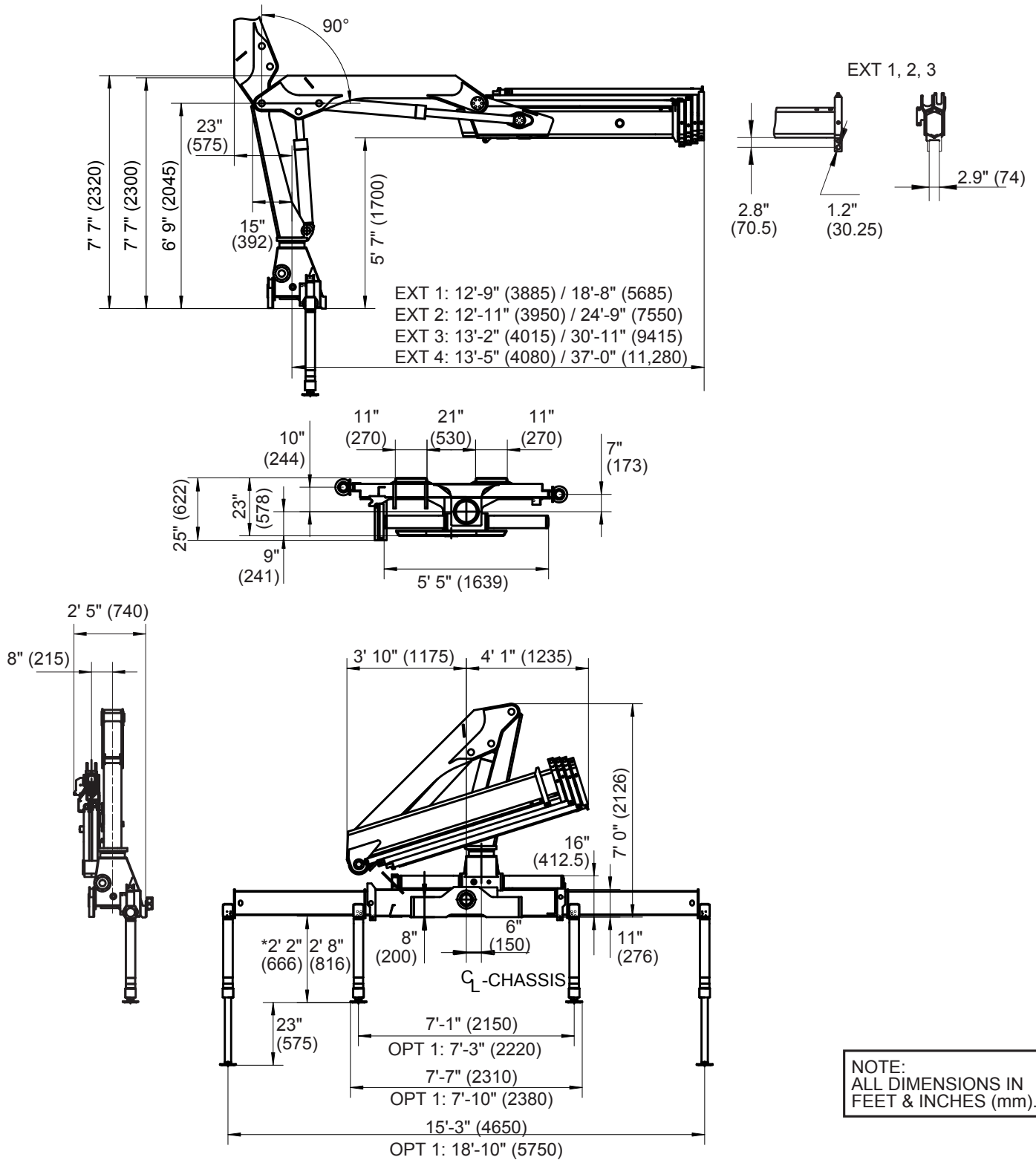

Iowa Mold Tooling Co., Inc.

500 Highway 18 West P.O. Box 189 Garner, Iowa 50438-0189
800-247-5958 641-923-3711 Fax: 641-923-6063 www.imt.com

IMT reserves the right to make changes in engineering, design, and specifications; add improvements; or discontinue manufacturing at any time without notice or obligation.

IMT and the IMT LOGO are registered trademarks or trademarks of Iowa Mold Tooling Co., Inc., Garner, IA, USA.

© 2008 Iowa Mold Tooling Co., Inc. All Rights Reserved.