

TRANSLIFT® MODEL MJ 1000R CRANE

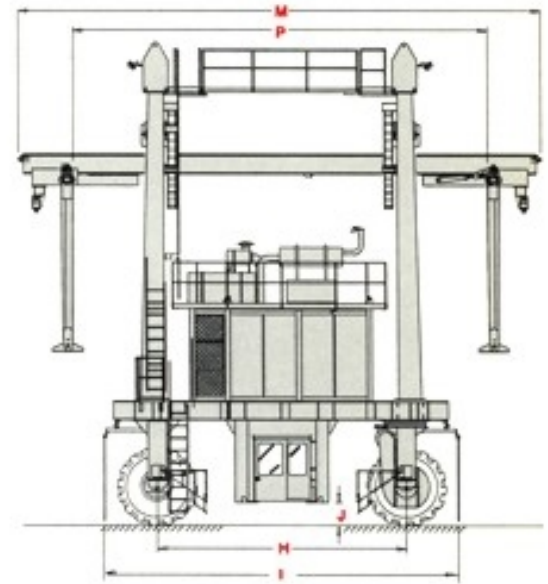

Specifications

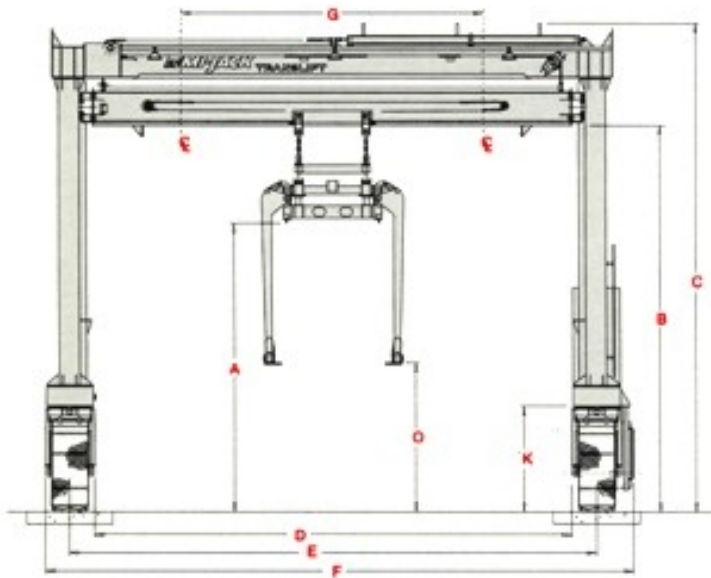

DIMENSION DATA

A. Height to Twistlocks	22'6"	22'6"	22'7"	22'7"
B. Height to Bottom of Stabilizing Beam (max.)	29'11"	29'11"	30'0"	31'7"
C. Overall Height of Machine	37'11"	37'11"	38'0"	40'0"
D. Inside Clear Width*	38'6"	43'6"	50'3"	60'3"
E. Wheel Tread C/L to C/L	42'6"	47'6"	55'3"	65'3"
F. Overall Width	47'6"	52'6"	61'2"	71'2"
G. Lateral Travel of Trolley	24'0"	29'0"	36'6"	46'6"
H. Wheel Base	20'0"	20'0"	20'0"	20'0"
I. Length to Outside of Wheel Guards	28'8"	28'8"	28'8"	28'8"
J. Cab to Ground	2'0"	2'0"	2'1"	2'1"
K. Ground Clearance to Side Beam	8'8"	8'8"	8'9.5"	8'9.5"
M. Overall Length of Grappler "B" Series	41'5"	41'5"	41'5"	41'5"
O. Maximum Height of Grappler Shoes	12'2"	12'2"	12'2"	12'2"
P. Grappler Arm Adjustment Range	(min.)	14'3"	14'3"	14'3"
	(max.)	34'3"	34'3"	34'3"

Tire Deflection is not included in these measurements.

*Other Machine sizes are available, Please call the factory for more information.

OPTIONAL SPECIFICATIONS & EQUIPMENT

- 20'-40' universal grappler
- Inside clear widths - 43' 6" - 50'3" - 60'3"
- Auxiliary hoist
- Second operators cab
- Special sound package
- Soft touch/side shift
- Wheel guards with automatic shutdown
- Air conditioner
- 500 gallon fuel tank

3111 West 167th Street, Hazel Crest, Illinois 60429 (708) 596-5200 Fax: (708) 225-2312



TRANSLIFT® MODEL MJ 1000R CRANE



Specifications

LIFT CAPACITY

Capacity under spreader 100,000 lbs.

HOIST SPEED

Rated load up 27 FPM

Rated load down 22 FPM

Trolley speed 0-114 FPM

GANTRY TRAVEL SPEED

Forward and reverse 0-3.5 MPH

..... 0-308 FPM

POWER SOURCE

Make and Model Detroit Diesel 6-71TA

Number of Cylinders 6

Displacement 426 cu. in.

Horsepower 208 @ 2,050 RPM(SAE)

HYDRAULIC SYSTEM

Remote over center variable displacement control pumps for hoist and drive functions. Solid state electric over hydraulic stepless controls ensure smooth operation.

STEERING

Full electric over hydraulic power steering.

Cylinder: Double acting, one at each steering wheel yoke.

HOIST

Each hoist is powered by a double acting hydraulic cylinder attached to heavy duty leaf chains. Leaf chains are attached at both ends of the patented stabilizing beam. There are three hoist chains with minimum ultimate strength per beam of 520,000 lbs.

Hoist Brakes: Hydraulic holding valve.

TRAVERSE

Each trolley is powered by a high-torque, low speed hydraulic motor and roller chain drive.

Traverse Chain: ANSI No. 120 Standard roller.

Roller Chain: Minimum ultimate strength 28,125 lbs.

DRIVE

Hydrostatic on drive wheels. One high torque, low speed hydraulic motor at each drive wheel yoke drives a single reduction roller chain final drive.

DRIVE BRAKE

Service: Hydraulic Regenerative type.

Parking: Disc, caliper type mounted on nondrive wheels, spring applied, hydraulic released.

TIRES

50' ICW & less: 29.5 x 29-32PR

51' ICW & above: 33.25 x 29-32PR

STANDARD EQUIPMENT

- 38'6" inside clear width
- 20'-40' expandable grappler with top and bottom pick capabilities
- Detroit Diesel 6-71TA diesel engine
- Low oil pressure, High temperature engine shutdown
- Low coolant level, low hydraulic level shutdown
- 29.5 x 29, 32 ply tires with wheel guards
- Enclosed cab, with tinted safety glass windows, acoustic insulation, electric over hydraulic joystick controls
- Instrument panel group including oil pressure gauge, water temperature gauge, horn & hour meter
- Windshield wiper - dual speed
- Container latch indicator lights
- Stanchion gun mounting bar
- Ground fueling
- Two fire extinguishers
- Safety railings
- Adjustable bucket seat for maximum operator comfort
- Heater and defroster
- 120/240 volt 12,500 watt generator
- 6-50 watt halogen lights
- 8-500 watt quartz lights
- Stanchion light package
- 3-12 volt halogen power unit lights
- Power unit enclosure
- Alternator 115 amp
- 300 gallon fuel tank capacity
- Maintenance platforms and ladders
- Tool rack
- Engine block heater
- Hydraulic reservoir heater
- Cold weather starting aid
- 110 volt outlet near each cab
- Standard power yellow paint
- 60 gallon Hydraulic reservoir
- 4 strobe lights with red lens
- Cab support
- 4 travel warning alarms

3111 West 167th Street, Hazel Crest, Illinois 60429 (708) 596-5200 Fax: (708) 225-2312

IMPORTANT: MI-JACK PRODUCTS reserves the right to change these specifications without notice and without incurring any obligation relating to such change.

