

KOBELCO

**COTAC Oy
NEW RK SERIES**

ROUGH TERRAIN CRANE

RK250

SPECIFICATIONS

Max. Lifting Capacity: **25 tons x 3.5 m**

Max. Boom Length: **30.6 m**



www.crane.fi

CE

SPECIFICATIONS

UPPER STRUCTURE



SWING UNIT

A hydraulic piston motor drives the swing pinion through a deck-mounted planetary gear reducer for 360° continuous rotation.

Hydraulic flow into the swing motor is controlled by a manual valve in the swing circuit. The brake valve allows the operator to select free or automatic braking when the swing control lever is set in neutral.

SWING PARKING BRAKE: manual disc brake

SWING GEAR: Internal spur gear

SLEWING RING: Integral with the swing gear, with a single row of ball bearings.

SWNG SPEED: 3.06 min⁻¹



WINCHES

Mounted side by side, power hoisting and lowering with inching capability. Hydraulic motor drive, spur gear reduction, and counterbalance valve.

BRAKES

Band type, with negative brake mode

DRUMS

Main hoist: 320 mm P.C.D. x 447 mm width

Aux. hoist: 320 mm P.C.D. x 228 mm width

WIRE ROPES

Main hoist: 16 mm dia. x 170 m, 4 x F (39) c/o anti twist rope

Aux. hoist: 16 mm dia. x 92 m, 4 x F (39) c/o anti twist rope

LINE SPEED

Main hoist: 124 m/min (at 4th layer)

Aux. hoist: 107 m/min (at 2nd layer)

BOOM HOIST

One-double acting hydraulic cylinder with holding valve.



BOOM TELESCOPE

Full power telescoping by two hydraulic cylinders with holding valves and telescoping assistance cables for the boom tip section.

CONTROLS

Four adjustable hand control levers for swing, main winch, auxiliary winch (with pedal), and boom hoist (with pedal). These can be tilted in three neutral positions and stored in their bases when not in use.

Other controls include: one short lever for swing parking brake; one lever for telescope; one lever for telescope change; one lever for transmission gear selection; swing lock pin; throttle control; and one travel brake pedal.



OPERATOR'S CAB

All-weather, wide-view, left-hand cab with safety glass, sliding door; roll-down window, and sashless roof window with wiper. Adjustable driver's seat with seat belt.

SAFETY DEVICES (Standard)

Moment limiter (auto-stop)	Multi-display
Swing range limit device	Working range limit device
Swing automatic stop device	Overhoist prevention device (auto-stop)
Base machine inclination meter	Interceptive lever lock for on and off
Outrigger extension width automatic detecting device	Auxiliary brake for operating
Swing lock device	Safety lock lever
Hydraulic safety valve	Sling wire lock
Boom telescoping default operation prevention device	Boom telescope safety device
Boom hoist safety device	Check & Safety Monitor
Winch drum safety device	Swing alarm lamps
Outrigger safety device	Anti-slip seat

HYDRAULIC SYSTEM



PUMPS

3 gear pumps and 2 single variable plunger pumps

1st pump : Boom hoist, boom telescope, and winch assist

2nd pump: Outriggers, and winch system

3rd pump: Swing and steering

4th pump : Pilot circuits for the clutches and negative brake cylinders, air conditioner.

5th pump : Steering assist, and power set jib

MOTORS : 3 plunger motors power the main hoist, the auxiliary hoist, and the swing.

CONTROL VALVES

Upper

One 5-stack valve : Winch, boom telescope, and boom hoist

One 2-stack valve : Clutch and brake

One 1-stack valve : Swing

Lower

Solenoid valves : Outriggers and suspension-lock system

One 2-stack valve : Steering

OIL RESERVOIR : 370 liters

CARRIER



TYPE

4-wheel drive (4WD), with 2-wheel drive (2WD) select for high speed mode.

MAX. TRAVEL SPEED: 49 km/h

GRADEABILITY: $\tan \theta$ 0.6 (31°)

PASSENGER: 1 person



OUTRIGGERS

Type: Hydraulic H-type outriggers.

Control: Eight double-acting hydraulic cylinders provide independent horizontal and

vertical movement for each outrigger. Outriggers can be set from inside the cab or at the side of the carrier.

Outrigger extension	6.3m	5.9m	5.1m	3.8m	2.105m
---------------------	------	------	------	------	--------



ENGINE

mitsubishi 6D16-TUA turbocharged, water-cooled diesel engine with 4 cycles, 6 cylinders, and direct injection.

Max. output: 158 kW at 2,800 min⁻¹

Max. torque: 706 N·m at 1,250 min⁻¹

Displacement: 7,545 cc

ELECTRICAL SYSTEM

24-volt DC system with two 12-volt batteries

FUEL TANK

Capacity 300 liters

TORQUE CONVERTER

3 element, single-stage, 2 phases, torque converter with fully automatically controlled lock-up clutch.

TRANSMISSION

3-speed for forward and 1-speed for reverse with high-low shift.

BRAKES

Service: Hydraulic and air booster disc brakes on all wheels.

Auxiliary: Torque converter lock-up linked electronic control exhaust brake, with ADS system.

Parking: Propel shaft brake internal expansion type with auxiliary brake for crane operation.



STEERING

Hydraulic power steering system with emergency steering device and about-face steering compensation device.

Steering modes:

Normal: 2W (front)	Rear: 2W (rear)
Cramp: 4W	Crab: 4W

SUSPENSION

Fully automatic steering, front and rear axles are fitted with hydro-pneumatic suspension with suspension lock system.

FRONT/REAR AXLES

Fully floating drive-steer type axles.



AXLE LOADING

Gross-Vehicle Weight	26,495 kg
Front-Vehicle Weight	13,245 kg
Rear-Vehicle Weight	13,250 kg

TIRES

Front/Rear: 445/95R25 177E ROAD

LIGHTS

Headlights	License plate light
Clearance light	Directional lights
Parking lights	Back light

SAFETY DEVICES

Emergency steering device
Rear steering auto-lock
Suspension lock device
Engine overrun warning buzzer
Check & Safety Monitor
Boom mirror
Reverse travel buzzer

ATTACHMENTS



BOOM

Boom consists of a boom base and three power telescoping sections. The first sections extended separately as do the 2nd section independently, and 3rd and 4th sections synchronized. All-welded, high tensile strength steel box construction.

Max. rated lifting capacity: 25.0 metric ton x 3.5 m

Fully retracted length: 9.3 m

Fully extended length: 30.6 m

Boom raising angle: 0° to 82°

Boom raising time: 47.6 sec

Boom telescoping time: 95.2 sec / 21.3 m



JIB

Compressed truss, 2-step drawing up type jib extendable to stored alongside boom. Jib swing down under the boom and set out. Jib offsets 5°, 25°, and 45° with suspension rods.

Jib length: 7.5 m/12.5 m

AUXILIARY SHEAVE

The auxiliary sheave permits one-part line operation.



HOOK BLOCK

4-sheave, 25 metric ton block with safety latch for main hoist, 3.5 metric ton hook with swivel and safety latch for aux. hoist.

LIFTING CAPACITIES

NOTES:

OPERATION WITH OUTRIGGERS

- Rated load do not exceed 75% of the tipping loads with machine set horizontally on a firm and level ground, satisfy the specified stability over the front, and include weight of hook block(s) and other handling accessories. Ratings shown in □ are based on the machine's structural strength, and others are determined by the machine's stability.
- The working radius given in the charts allow for loaded boom deflection. Always operate the machine on the basis of actual operating radius.
- Weight of hooks, hook blocks, slings and other lifting devices are a part of the total load. Their total weight must be subtracted load to obtain the weight that can be lifted.

Hooks	25-ton	3.5-ton
Weight	210 kg	70 kg

- Maximum outrigger extension is 6.3 m. Three intermediate extension positions are also provided at 5.9 m, 5.1 m and 3.8 m. Minimum outrigger extension is 2.105 m.

Over-the-front area

Over-the-rear area

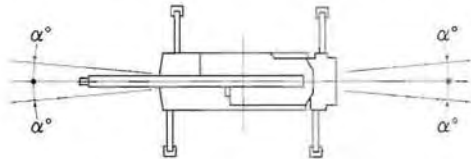

Outrigger extension	5.9m	5.1m	3.8m	Min. outrigger extension
α°	33°	28°	20°	5°

- Rated load in the over-the-side whole around various depending on the extension position of outriggers. Therefore, crane operation must be performed based on the rating chart corresponding to each extended outrigger position.
- To determine load ratings that fall between those shown in the charts, proceed as follows:
 - For boom lengths not listed use rating for next longer boom length or next shorter boom length, whichever is smaller.
 - For load radii not shown, use rating for next larger radius.
- Ratings of the auxiliary sheave are the same as main boom ratings, but should not exceed 3,500kg. Ratings of the auxiliary sheave are calculated by deducting 25-ton hook weight (210 kg) from main boom ratings.
- Jib operation must be based on the main boom angle.
- Ratings of the boom with extended jib are calculated by deducting 1,550 kg at 7.5m jib or 1,750 kg at 12.0m jib besides the weight of 25-ton hook block and the sling wire from the rated loads. At this time, do not use the auxiliary sheave.
- In such a condition not shown in the rating chart, operation is impossible. Lowering the boom over critical degrees leads to overturn even with no load. Be careful extremely.
- Standard hoist reevings are shown below. Rated single-line pull must not exceed 3,500 kg.

Boom length	9.32m	16.42m	23.52m	30.62m	Jib aux. sheave
Hook	25-ton				3.5-ton
No. of reeving	8	6	4	4	1

- In lifting load operation in an oblique direction (direction toward the outrigger), sometimes the outrigger float in the diagonal side against the lifted load may be raised depending on a condition. This is caused by torsional rigidity and deflection of the carrier frame, and stability is not lost. The stability of this machine in operation within the rating is secured in the condition that the machine is set horizontally on a level and firm ground.

OPERATION WITHOUT OUTRIGGERS (ON TIRES)

- Rated load do not exceed 75% of the tipping loads with machine set horizontally on a firm and level ground, satisfy the specified stability over the front, and include weight of hook block(s) and other handling accessories. Ratings shown in □ are based on the machine's structural strength, and others are determined by the machine's stability. Tire specified air pressure is set to 775kPa (7.75 kgf/cm²)
- The working radius given in the charts allow for loaded boom deflection. Always operate the machine on the basis of actual operating radius.
- Weight of hooks, hook blocks, slings and other lifting devices are a part of the total load. Their total weight must be subtracted load to obtain the weight that can be lifted.

Hooks	25-ton	3.5-ton
Weight	210 kg	70 kg

*Tire specified air pressure: 775kPa (7.75 kgf/cm²)

- Load ratings differ for over-the-front and over-the-side operation. Care must e taken to avoid overload when swinging a load from an over-the-front position to an over-the-side position.

Over-the-front area

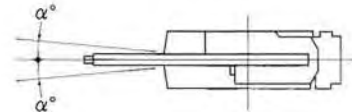

On tires	Stationery	Pick & carry
α° (FRONT)	1°	1°

- Ratings of the auxiliary sheave are the same as main boom ratings, but should not exceed 3,500 kg. Ratings of the auxiliary sheave are calculated by deducting 25-ton hook weight (210 kg) or 3.5-ton hook weight (70 kg) from main boom ratings.
- Parking brake and auxiliary operation brake must be applied during stationary load lifting.
- Pick and carry operations must be done in the low travel mode.
- During pick and carry operations, keep the load close to the ground to avoid swaying, and travel no faster than 2.0 km/h. Avoid cornering, sudden starts (acceleration), and sudden braking. Boom must be centered over the front area.
- Do not operate the crane functions while carrying the load.
- Standard hoist reevings are shown below. Single-line load must not exceed 3,500 kg.

Boom length	9.32m	16.42m	23.52m	Jib aux. sheave
Hook	25-ton			3.5-ton
No. of reeving	8	4	4	1

BOOM LIFTING CAPACITIES

COTAC Oy
RK250

Main Boom Lifting Capacities with Outriggers

Unit: metric ton

MAIN	With outriggers in 6.3m position				With outriggers in 5.9m position				With outriggers in 5.1m position				With outriggers in 3.8m position				With outriggers in 2.105m position			
	360° swing area				Over the side				Over the side				Over the side				Over the side			
	Boom length in meters				Boom length in meters				Boom length in meters				Boom length in meters				Boom length in meters			
Operating radius (m)	9.32	16.42	23.52	30.62	9.32	16.42	23.52	30.62	9.32	16.42	23.52	30.62	9.32	16.42	23.52	30.62	9.32	16.42	23.52	30.62
2.5	25.00	19.00			25.00	19.00			25.00	19.00			25.00	19.00			11.10	10.00		
3.0	25.00	19.00			25.00	19.00			25.00	19.00			25.00	19.00			11.10	10.00		
3.5	25.00	19.00	12.50		25.00	19.00	12.50		25.00	19.00	12.50		20.00	19.00	12.50		8.40	8.00	9.30	
4.0	23.00	19.00	12.50		23.00	19.00	12.50		23.00	19.00	12.50		15.70	15.60	12.50		6.70	6.30	7.20	
4.5	21.20	18.00	12.50		21.20	18.00	12.50		21.20	18.00	12.50		12.60	12.60	12.50		5.50	5.10	5.90	
5.0	19.40	16.70	12.50	7.00	19.40	16.70	12.50	7.00	18.10	16.70	12.50	7.00	10.60	10.30	10.50	7.00	4.55	4.20	4.90	5.30
5.5	17.80	15.60	11.85	7.00	17.80	15.60	11.85	7.00	15.35	15.60	11.85	7.00	9.05	8.70	9.00	7.00	3.85	3.50	4.15	4.50
6.0	16.30	14.60	11.20	7.00	16.30	14.60	11.20	7.00	12.90	12.80	11.20	7.00	7.70	7.50	7.80	7.00	3.30	2.95	3.55	3.90
6.5	15.10	13.80	10.60	7.00	15.10	13.80	10.60	7.00	11.10	10.80	10.60	7.00	6.60	6.50	6.85	7.00	2.85	2.45	3.05	3.35
6.8	8.60	13.30	10.30	7.00	8.60	13.30	10.30	7.00	8.60	9.90	10.30	7.00	6.00	5.90	6.40	6.65	2.60	2.20	2.75	3.05
7.0		13.00	10.10	7.00		12.65	10.10	7.00		9.40	10.10	7.00		5.60	6.10	6.40		2.05	2.60	2.85
7.5		12.20	9.60	7.00		10.95	9.60	7.00		8.20	9.00	7.00		4.90	5.50	5.75		1.70	2.20	2.45
8.0		10.90	9.10	7.00		9.65	9.10	7.00		7.30	8.05	7.00		4.40	4.90	5.15		1.40	1.90	2.10
9.0		8.65	8.20	6.40		7.60	8.20	6.40		5.85	6.45	6.40		3.50	3.95	4.20		0.90	1.40	1.60
10.0		7.05	7.40	5.90		6.20	6.90	5.90		4.75	5.35	5.75		2.80	3.25	3.50			1.05	1.25
11.0		5.85	6.50	5.35		5.10	5.80	5.35		3.90	4.50	4.75		2.25	2.70	2.95				0.95
12.0		4.95	5.45	4.90		4.30	4.95	4.90		3.30	3.80	4.10		1.80	2.25	2.50				
13.0		4.20	4.70	4.50		3.70	4.25	4.50		2.75	3.25	3.50		1.40	1.90	2.15				
13.5		3.90	4.40	4.30		3.40	4.00	4.25		2.50	3.00	3.25		1.20	1.75	2.00				
13.9		3.70	4.15	4.20		3.25	3.80	4.00		2.30	2.85	3.10		1.00	1.65	1.90				
14.0			4.10	4.15			3.75	3.95			2.80	3.05			1.60	1.85				
15.0			3.60	3.85			3.25	3.40			2.45	2.65			1.35	1.55				
16.0			3.15	3.45			2.80	3.00			2.10	2.35			1.10	1.35				
17.0			2.80	3.05			2.45	2.65			1.80	2.05			0.95	1.15				
18.0			2.45	2.70			2.15	2.35			1.55	1.80			0.75	1.00				
19.0			2.15	2.45			1.90	2.10			1.35	1.55			0.60	0.85				
20.0			1.90	2.20			1.65	1.90			1.15	1.40				0.70				
21.0			1.70	1.95			1.50	1.70				1.20								
22.0				1.75				1.50				1.05								
24.0				1.40				1.15				0.75								
26.0				1.15				0.90				0.50								
28.0				0.95				0.65												
28.1				0.95				0.65												
Min. boom angle	0°	0°	0°	0°	0°	0°	0°	0°	0°	0°	15°	23°	0°	0°	26°	44°	0°	48°	60°	66°

MAIN	Stationary						Pick & Carry (under 2 km/h)					
	360° swing area			Over the front			360° swing area			Over the front		
	Boom length in meters			Boom length in meters			Boom length in meters			Boom length in meters		
Operating radius (m)	9.32	16.42	23.52	9.32	16.42	23.52	9.32	16.42	23.52	9.32	16.42	23.52
3.0	8.15	7.30		14.00	9.00		5.90	5.30		10.10	6.50	
3.5	6.05	5.60	4.50	14.00	9.00	6.50	4.40	4.00	3.20	10.10	6.50	4.70
4.0	4.65	4.40	4.50	12.60	9.00	6.50	3.30	3.20	3.20	9.10	6.50	4.70
4.5	3.65	3.40	3.90	11.25	9.00	6.50	2.60	2.40	2.80	8.10	6.50	4.70
5.0	2.90	2.70	3.35	9.90	8.15	6.50	2.10	1.90	2.40	7.10	5.90	4.70
5.5	2.30	2.10	2.80	8.55	7.35	6.15	1.70	1.50	2.00	6.20	5.30	4.40
6.0	1.80	1.65	2.30	7.20	6.60	5.80	1.30	1.20	1.70	5.20	4.80	4.20
6.5	1.40	1.30	1.90	6.15	5.90	5.45	1.00	0.90	1.40	4.40	4.20	3.90
6.8	1.15	1.10	1.70	5.60	5.40	5.25	0.80	0.75	1.25	3.95	3.90	3.75
7.0		1.00	1.60		5.20	5.10		0.70	1.20		3.70	3.70
8.0		0.50	1.10		4.00	4.40			0.80		2.90	3.20
9.0			0.70		3.05	3.70			0.50		2.20	2.70
10.0					2.40	3.00					1.70	2.20
11.0					1.85	2.45					1.30	1.80
12.0					1.40	2.00					1.00	1.40
13.0					1.05	1.65					0.80	1.20
14.0						1.35						1.00
15.0						1.10						0.80
16.0						0.85						0.60
17.0						0.85						0.50
Min. boom angle	0°	53°	62°	0°	22°	36°	0°	57°	62°	0°	22°	36°

JIB LIFTING CAPACITIES

Jib Lifting Capacities with Outriggers

Unit: metric ton

6.3 M						
With outriggers in 6.3m position (360° swing area)						
Boom angle	7.5 m Jib			12.0 m Jib		
	Jib angle:5°	Jib angle:25°	Jib angle:45°	Jib angle:5°	Jib angle:25°	Jib angle:45°
82°	3.00	2.10	1.44	2.00	1.25	1.00
80°	3.00	2.10	1.44	2.00	1.25	1.00
75°	3.00	2.10	1.35	2.00	1.18	1.00
73.5°	3.00	2.10	1.33	1.87	1.15	1.00
71°	3.00	2.10	1.30	1.70	1.10	0.95
69°	2.82	2.10	1.27	1.58	1.06	0.91
65°	2.50	1.88	1.23	1.40	1.01	0.84
60°	2.10	1.65	1.20	1.20	0.94	0.74
55°	1.51	1.28	1.18	1.10	0.88	0.64
52°	1.22	1.08	0.99	0.92	0.84	0.59
50°	1.05	0.95	0.88	0.81	0.74	0.54
48°	0.91	0.84	0.79	0.72	0.65	0.51
45°	0.74	0.70	0.70	0.59	0.53	0.45
40°	0.50	0.44		0.44	0.38	
37°	0.39	0.32		0.36	0.30	
36°	0.35	0.30		0.33	0.27	
35°	0.32	0.28		0.31		
34°	0.30	0.26				
32°	0.26					
Min. boom angle	32°	34°	45°	35°	36°	45°

5.9 M						
With outriggers in 5.9m position (Over the side)						
Boom angle	7.5 m Jib			12.0 m Jib		
	Jib angle:5°	Jib angle:25°	Jib angle:45°	Jib angle:5°	Jib angle:25°	Jib angle:45°
82°	3.00	2.10	1.44	2.00	1.25	1.00
80°	3.00	2.10	1.44	2.00	1.25	1.00
75°	3.00	2.10	1.35	2.00	1.18	1.00
73.5°	3.00	2.10	1.33	1.87	1.15	1.00
71°	3.00	2.10	1.30	1.70	1.10	0.95
70°	2.90	2.10	1.28	1.64	1.08	0.93
69°	2.82	2.10	1.27	1.58	1.06	0.91
65°	2.50	1.88	1.23	1.40	1.01	0.84
60°	1.85	1.49	1.20	1.20	0.94	0.74
55°	1.19	1.05	0.92	0.96	0.86	0.64
52°	0.89	0.82	0.76	0.76	0.67	0.59
50°	0.74	0.69	0.65	0.61	0.55	0.52
49°	0.68	0.63	0.59	0.54	0.50	0.47
48°	0.61	0.56	0.53	0.47	0.44	0.43
45°	0.46	0.40	0.37	0.30	0.29	0.28
42°	0.32	0.27				
40°	0.26					
Min. boom angle	40°	42°	45°	45°	45°	45°

5.1 M						
With outriggers in 5.1m position (Over the side)						
Boom angle	7.5 m Jib			12.0 m Jib		
	Jib angle:5°	Jib angle:25°	Jib angle:45°	Jib angle:5°	Jib angle:25°	Jib angle:45°
82°	3.00	2.10	1.44	2.00	1.25	1.00
80°	3.00	2.10	1.44	2.00	1.25	1.00
75°	3.00	2.10	1.35	2.00	1.18	1.00
73.5°	3.00	2.10	1.33	1.87	1.15	1.00
72°	3.00	2.10	1.31	1.75	1.12	0.97
71°	2.84	2.10	1.30	1.70	1.10	0.95
70°	2.67	2.10	1.28	1.64	1.08	0.93
69°	2.52	2.00	1.27	1.58	1.06	0.91
65°	1.95	1.60	1.23	1.40	1.01	0.84
63°	1.70	1.42	1.10	1.23	0.99	0.80
60°	1.34	1.15	0.94	1.02	0.82	0.74
55°	0.86	0.76	0.70	0.69	0.56	0.52
52°	0.63	0.56	0.56	0.52	0.42	0.40
50°	0.50	0.45	0.45	0.40	0.35	0.32
49°	0.45	0.40	0.40			
45°	0.30	0.26	0.26			
Min. boom angle	45°	45°	45°	50°	50°	50°

3.8 M	With outriggers in 3.8m position (Over the side)					
	7.5 m Jib			12.0 m Jib		
	Jib angle:5°	Jib angle:25°	Jib angle:45°	Jib angle:5°	Jib angle:25°	Jib angle:45°
82°	3.00	2.10	1.44	2.00	1.25	1.00
80°	3.00	2.10	1.44	2.00	1.25	1.00
75°	3.00	2.10	1.35	2.00	1.18	1.00
73.5°	2.60	1.94	1.33	1.82	1.15	1.00
71°	2.00	1.61	1.30	1.52	1.10	0.95
69°	1.60	1.36	1.05	1.27	0.94	0.91
65°	1.00	0.88	0.75	0.83	0.66	0.60
60°	0.52	0.48	0.47	0.45	0.35	0.33
55°	0.28	0.26				
Min. boom angle	55°	55°	60°	60°	60°	60°

Working Ranges

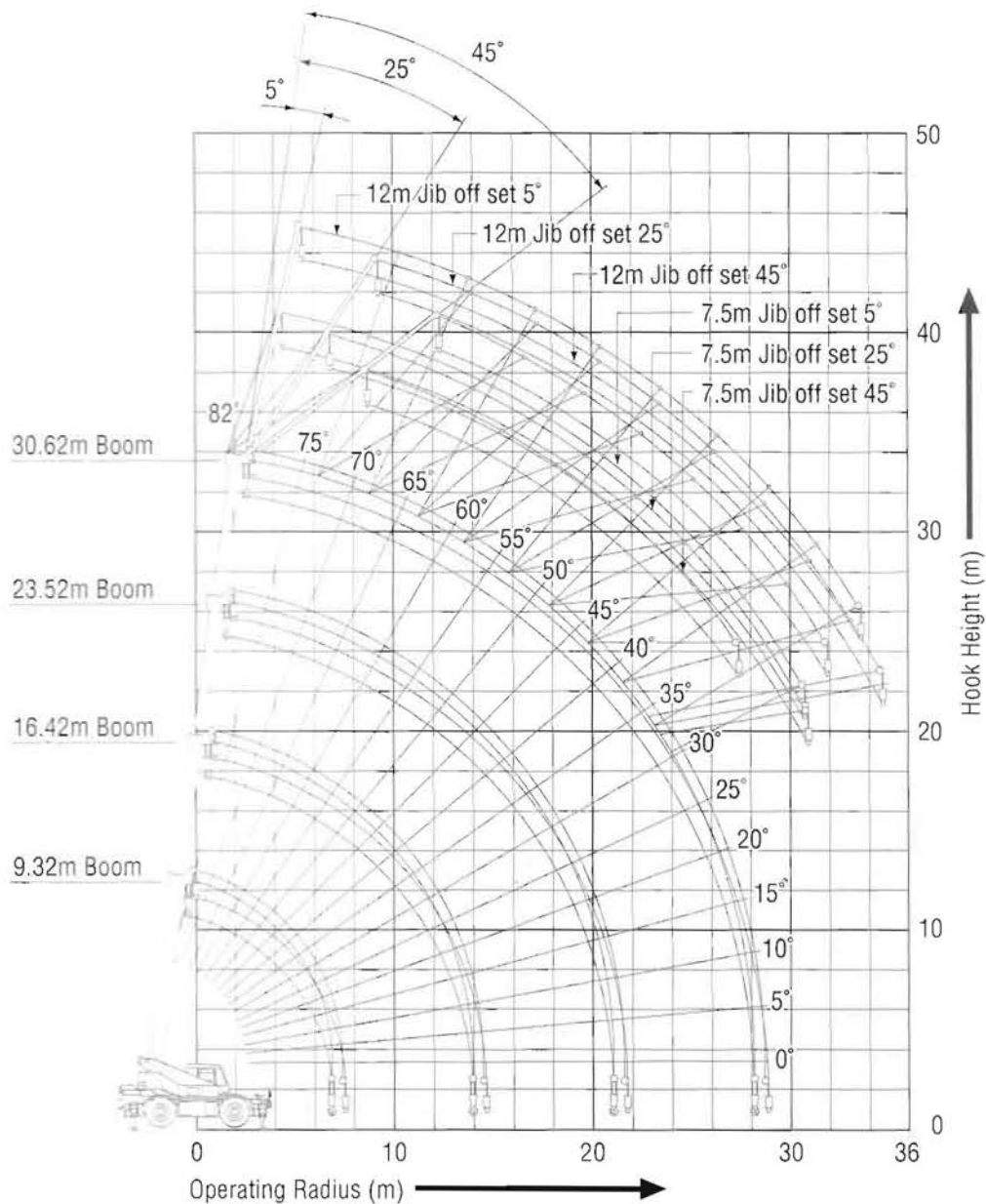

*Boom/jib bending with load is not involved in figure of working ranges.

DIMENSIONS

RK250

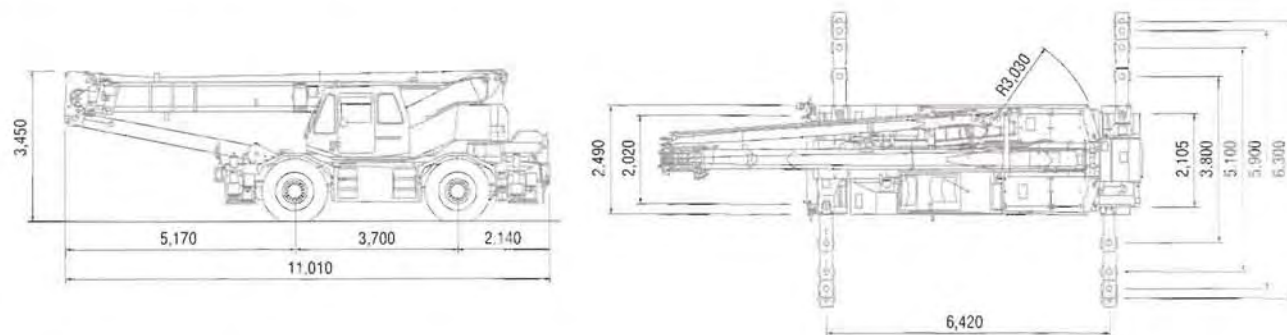

TURNING RADIUS

2-Drive Steering (Front)

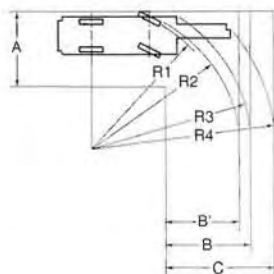

R1	Minimum turning radius	9.30m
R2	Tire clearance with cab	9.51m
R3	Carrier clearance	10.30m
R4	Boom clearance	11.86m
A	Entrance width (carrier)	4.81m
B	Exit width (carrier)	5.56m
B'	Exit width (tires)	4.80m
C	Exit width (boom)	7.17m

4-Drive Steering

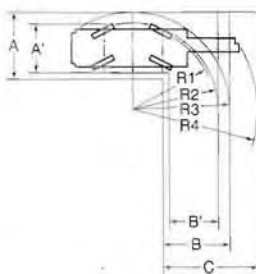

R1	Minimum turning radius	5.20m
R2	Tire clearance with cab	5.45m
R3	Carrier clearance	6.25m
R4	Boom clearance	8.19m
A	Entrance width (carrier)	4.39m
A'	Entrance width (tires)	3.25m
B	Exit width (carrier)	4.39m
B'	Exit width (tires)	3.25m
C	Exit width (boom)	6.39m

2-Drive Steering (Rear)

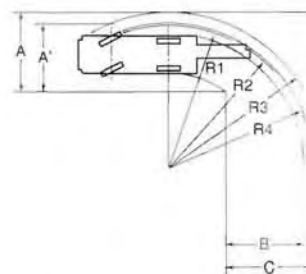

R1	Minimum turning radius	9.30m
R2	Tire clearance with cab	9.51m
R3	Carrier clearance	10.30m
R4	Boom clearance	9.44m
A	Entrance width (carrier)	5.25m
A'	Entrance width (tires)	4.80m
B	Exit width (carrier)	5.25m
C	Exit width (boom)	5.78m

STANDARD EQUIPMENT

Engine tachometer
Tachograph
Hourmeter
Engine over running alarm
Paper-element air cleaner
Three working lights
Horn
Towing hooks (one front, one rear)
Outrigger plates
Oil cooler
Cab heater/defroster
Air conditioner
Operation Manual: one set

OTHER AMENITIES

Radio
Cigarette lighter
Ashtray
Sun visor
Floor mat
Windshield wiper/washer

OPTIONAL EQUIPMENT

Extra hydraulic oil cooler for hydraulic system

Note: Due to our policy of continual product improvements all designs and specifications are subject to change without advance notice.

KOBELCO CONSTRUCTION MACHINERY CO., LTD.

3-13, Nihonbashi 1-chome, Chuo-ku, TOKYO, 103 www.crane.fi
 Tel: ++81 (0)3-3278-7080/ Fax: ++81 (0)3-3278-7138