

Load Rating Chart

Model 5096S



© Manitex 2000

NOTE: Additional copies of this Load Rating Chart can be purchased from your Manitex Distributor. When ordering, use the part number shown in the bottom left corner of this page.

LMI OPERATING CODES

CODE	CRANE CONFIGURATION	OUTRIGGER CONFIGURATION	AREA OF OPERATION
#1	— MAIN BOOM — — — — —	FULLY EXTENDED — — — — —	OVER REAR
#3	— MAIN BOOM — — — — —	FULLY EXTENDED — — — — —	FULL 360°
#4	— MAIN BOOM — — — — —	MID POSITION — — — — —	FULL 360°
#5	— MAIN BOOM — — — — —	RETRACTED — — — — —	FULL 360°
#6	— MAIN BOOM — — — — —	ON TIRES — — — — —	DIRECTLY OVER REAR
#7	— RETRACTED JIB 0° OFFSET — — — — —	FULLY EXTENDED — — — — —	OVER REAR
#8	— RETRACTED JIB 0° OFFSET — — — — —	FULLY EXTENDED — — — — —	FULL 360°
#9	— RETRACTED JIB 15° OFFSET — — — — —	FULLY EXTENDED — — — — —	OVER REAR
#10	— RETRACTED JIB 15° OFFSET — — — — —	FULLY EXTENDED — — — — —	FULL 360°
#11	— RETRACTED JIB 30° OFFSET — — — — —	FULLY EXTENDED — — — — —	OVER REAR
#12	— RETRACTED JIB 30° OFFSET — — — — —	FULLY EXTENDED — — — — —	FULL 360°
#13	— EXTENDED JIB 0° OFFSET — — — — —	FULLY EXTENDED — — — — —	OVER REAR
#14	— EXTENDED JIB 0° OFFSET — — — — —	FULLY EXTENDED — — — — —	FULL 360°
#15	— EXTENDED JIB 15° OFFSET — — — — —	FULLY EXTENDED — — — — —	OVER REAR
#16	— EXTENDED JIB 15° OFFSET — — — — —	FULLY EXTENDED — — — — —	FULL 360°
#17	— EXTENDED JIB 30° OFFSET — — — — —	FULLY EXTENDED — — — — —	OVER REAR
#18	— EXTENDED JIB 30° OFFSET — — — — —	FULLY EXTENDED — — — — —	FULL 360°
#19	— RETRACTED JIB 0° OFFSET — — — — —	MID POSITION — — — — —	FULL 360°
#20	— RETRACTED JIB 15° OFFSET — — — — —	MID POSITION — — — — —	FULL 360°
#21	— RETRACTED JIB 30° OFFSET — — — — —	MID POSITION — — — — —	FULL 360°
#22	— EXTENDED JIB 0° OFFSET — — — — —	MID POSITION — — — — —	FULL 360°
#23	— EXTENDED JIB 15° OFFSET — — — — —	MID POSITION — — — — —	FULL 360°
#24	— EXTENDED JIB 30° OFFSET — — — — —	MID POSITION — — — — —	FULL 360°
#25	— PERSONNEL LIFTING MAIN BOOM — — — — —	FULLY EXTENDED — — — — —	FULL 360°
#26	— PERSONNEL LIFTING RETR JIB 0° OFFSET — — — — —	FULLY EXTENDED — — — — —	FULL 360°
#27	— PERSONNEL LIFTING RETR JIB 15° OFFSET — — — — —	FULLY EXTENDED — — — — —	FULL 360°
#28	— PERSONNEL LIFTING RETR JIB 30° OFFSET — — — — —	FULLY EXTENDED — — — — —	FULL 360°
#29	— PERSONNEL LIFTING EXTENDED JIB 0° OFFSET — — — — —	FULLY EXTENDED — — — — —	FULL 360°
#30	— PERSONNEL LIFTING EXTENDED JIB 15° OFFSET — — — — —	FULLY EXTENDED — — — — —	FULL 360°
#31	— PERSONNEL LIFTING EXTENDED JIB 30° OFFSET — — — — —	FULLY EXTENDED — — — — —	FULL 360°

WARNING

1. THE OPERATOR MUST READ AND UNDERSTAND THE OWNER'S MANUAL BEFORE OPERATING THIS CRANE.

2. POSITIONING OR OPERATION OF CRANE BEYOND AREAS SHOWN ON THIS CHART IS NOT INTENDED OR APPROVED EXCEPT WHERE SPECIFIED IN OWNER'S MANUAL.

3. LOADED BOOM ANGLES AT SPECIFIED BOOM LENGTHS GIVE ONLY AN APPROXIMATION OF THE OPERATING RADIUS. THE BOOM ANGLE BEFORE LOADING SHOULD BE GREATER TO ACCOUNT FOR DEFLECTIONS. DO NOT EXCEED THE OPERATING RADIUS FOR RATED LOADS.

4. THE OPERATING RADIUS SHOWN IN THE JIB RATING CHART IS FOR FULLY EXTENDED BOOM ONLY. WHEN BOOM IS NOT FULLY EXTENDED, USE ONLY LOADED BOOM ANGLE TO DETERMINE LOAD RATING OF JIB.

5. FOR BOOM ANGLES NOT SHOWN ON JIB LOAD RATING CHART, USE RATING OF NEXT LOWER BOOM ANGLE.

WARNING (CONTINUED)

6. FOR BOOM LENGTHS NOT SHOWN, USE RATING OF NEXT SHORTER OR LONGER BOOM LENGTH, WHICHEVER IS LESS. FOR RADII NOT SHOWN, USE RATING OF NEXT LONGER RADIUS.
7. CRANE LOAD RATINGS ON OUTRIGGERS ARE BASED ON FREELY SUSPENDED LOADS WITH THE MACHINE LEVELED AND STANDING ON A FIRM UNIFORM SUPPORTING SURFACE. NO ATTEMPT SHALL BE MADE TO MOVE A LOAD HORIZONTALLY ON THE GROUND IN ANY DIRECTION.
8. PRACTICAL WORKING LOADS DEPEND ON SUPPORTING SURFACE, WIND, AND OTHER FACTORS AFFECTING STABILITY SUCH AS HAZARDOUS SURROUNDINGS, EXPERIENCE OF PERSONNEL, AND PROPER HANDLING, ALL OF WHICH MUST BE TAKEN INTO ACCOUNT BY THE OPERATOR.
9. THE MAXIMUM LOAD WHICH MAY BE TELESCOPED IS LIMITED BY HYDRAULIC PRESSURE, BOOM ANGLE, AND BOOM LUBRICATION. IT IS SAFE TO ATTEMPT TO TELESCOPE ANY LOAD WITHIN THE LIMITS OF THE LOAD RATING CHART.
10. LIFTING OFF THE MAIN BOOM POINT WHILE THE SWING AROUND JIB IS ERECTED IS NOT INTENDED OR APPROVED.

INFORMATION

1. DEDUCTIONS MUST BE MADE FROM RATED LOADS FOR STOWED JIB, OPTIONAL ATTACHMENTS, HOOKS, AND LOADBLOCKS (SEE DEDUCTION CHART). WEIGHTS OF SLINGS AND ALL OTHER LOAD HANDLING DEVICES SHALL BE CONSIDERED A PART OF THE LOAD.
2. LOAD RATINGS ABOVE THE HEAVY LINE ARE STRUCTURALLY LIMITED CAPACITIES. LOAD RATINGS BELOW THE HEAVY LINE ARE STABILITY LIMITED CAPACITIES AND DO NOT EXCEED 85 % OF TIPPING.

DEFINITIONS

1. OPERATING RADIUS IS THE HORIZONTAL DISTANCE FROM THE AXIS OF ROTATION TO THE CENTER OF THE VERTICAL HOIST LINE OR TACKLE WITH LOAD APPLIED.
2. LOADED BOOM ANGLE IS THE INCLUDED ANGLE BETWEEN THE HORIZONTAL AND LONGITUDINAL AXES OF THE BOOM BASE AFTER LIFTING RATED LOAD AT RATED RADIUS.

ALLOWABLE LINE PULL										WARNING
1 PART LINE	2 PART LINE	3 PART LINE	4 PART LINE	5 PART LINE	6 PART LINE	7 PART LINE	8 PART LINE	9 PART LINE	10 PART LINE	
10000 LBS	20000 LBS	30000 LBS	40000 LBS	50000 LBS	60000 LBS	70000 LBS	80000 LBS	90000 LBS	100000 LBS	5/8" XLT4 LOW-TORQUE (3.5:1 SF) - 35000 LBS MIN BREAKING STRENGTH

ANTI-TWO-BLOCK SYSTEM MUST BE IN GOOD OPERATING CONDITION BEFORE OPERATING CRANE.

REFER TO THE OWNER'S MANUAL.

KEEP AT LEAST 3 WRAPS OF LOAD LINE ON THE DRUM AT ALL TIMES.

AREA OF OPERATIONS

ON TIRES

WHEN LIFTING ON TIRES, THE BOOM MUST BE CENTERED OVER THE REAR OF THE CRANE WITH THE SWING BRAKE AND THE HOUSELOCK ENGAGED.

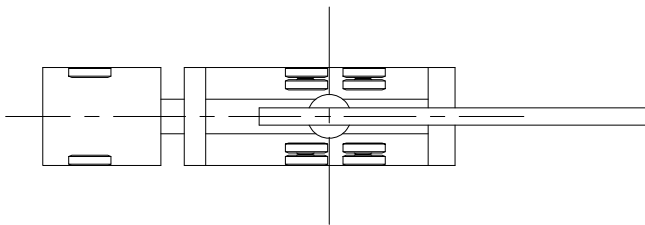

ON OUTRIGGERS

FULL 360°

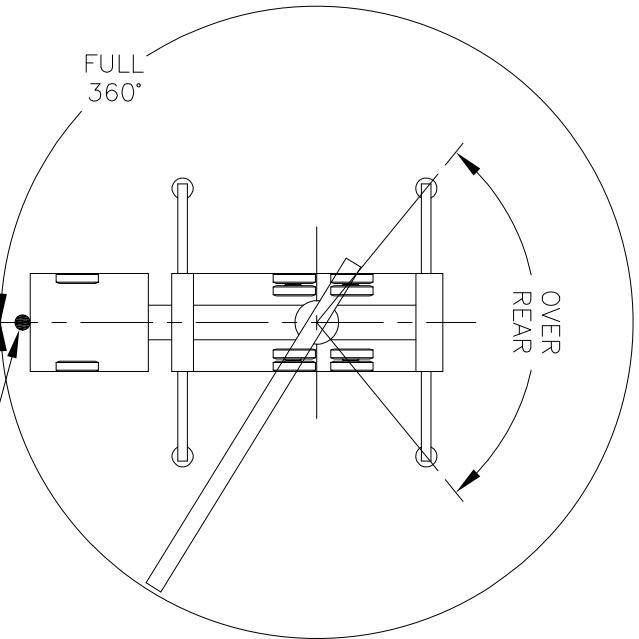

THE FRONT BUMPER STABILIZER MUST BE SET IN ACCORDANCE TO THE OPERATORS MANUAL BEFORE WORKING IN THE "FULL 360°" AREA.

DEDUCTIONS FROM RATED LOADS FOR LOAD HANDLING DEVICES SUPPLIED BY MANITEX

AUXILIARY BLOCK	-----	50 LBS
ROOSTER SHEAVE	-----	70 LBS
LIFTING FROM MAIN BOOM WITH JIB STOWED OR ERECTED	-----	SEE LOAD CHART
OVERHAUL BALL	-----	SEE MANUFACTURER NAMEPLATE
LOAD BLOCK	-----	SEE MANUFACTURER NAMEPLATE

- RANGE DIAGRAM -

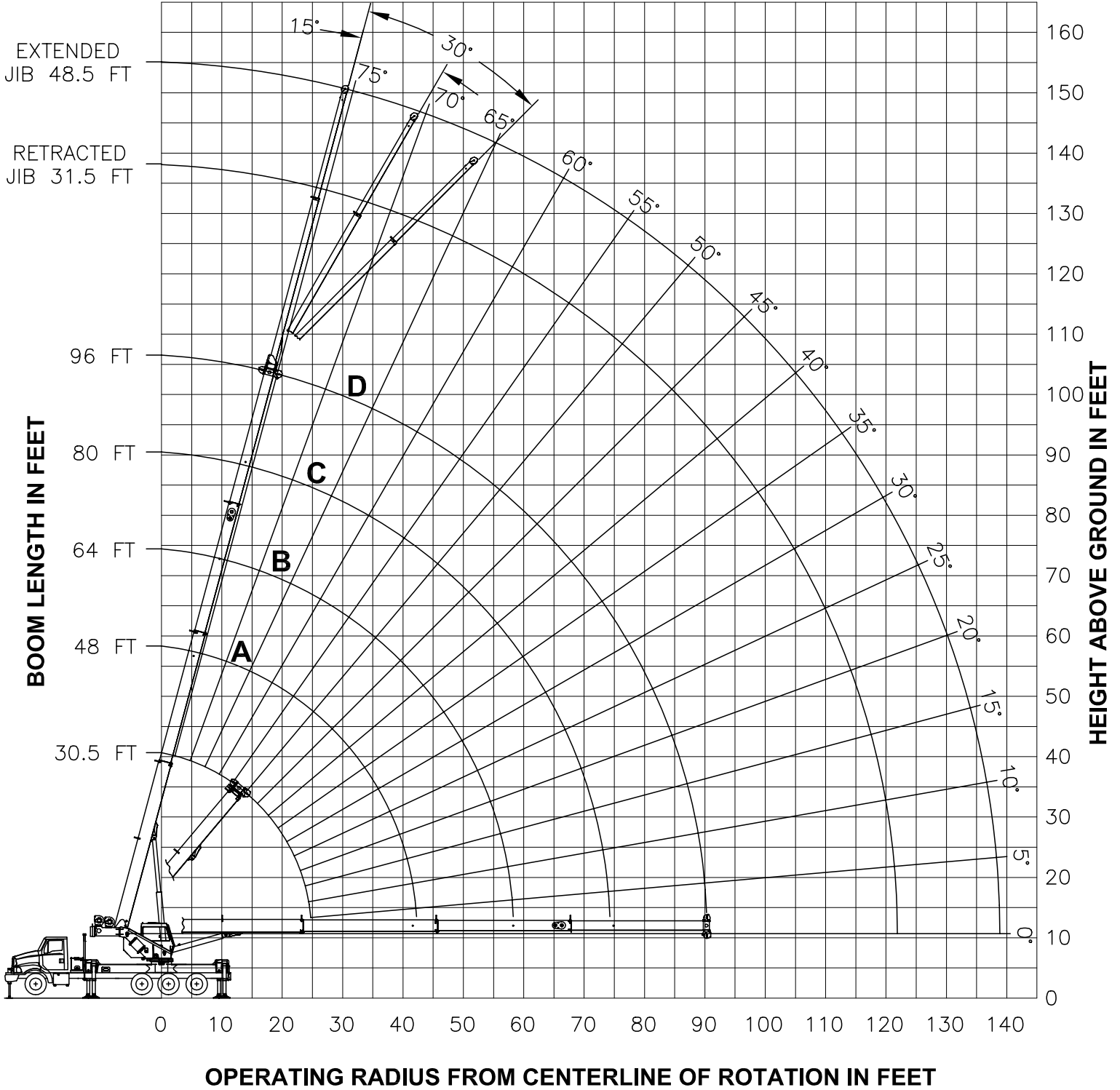

USE THIS CHART ONLY WHEN ALL OUTRIGGER BEAMS ARE FULLY EXTENDED

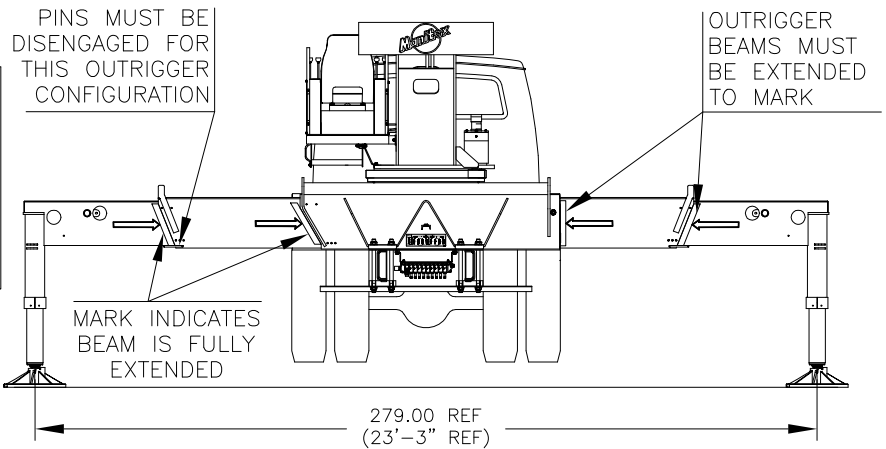

MAIN BOOM LIFTING CAPACITIES

LOAD RADIUS (FT)	BOOM LENGTH 30.5 FT			BOOM LENGTH 48 FT (A)			BOOM LENGTH 64 FT (B)			DEDUCTIONS FOR JIB FROM MAIN BOOM CAPACITIES	
	LOADED BOOM ANGLE (DEG)	CODE 1 OVER REAR (LBS)	CODE 3 FULL 360° (LBS)	LOADED BOOM ANGLE (DEG)	CODE 1 OVER REAR (LBS)	CODE 3 FULL 360° (LBS)	LOADED BOOM ANGLE (DEG)	CODE 1 OVER REAR (LBS)	CODE 3 FULL 360° (LBS)		
6	69	100000	100000								
8	65	90400	90400								
10	61	80000	80000	73	51000	51000					
12	56	71800	71800	70	51000	51000					
15	49	61700	61700	66	51000	51000	73	40000	40000		
20	34	46100	46100	59	47000	47000	69	37700	37700		
25				52	36800	36800	64	30400	30400		
30				44	29480	25890	59	27040	26420		
35				34	22630	19320	53	23100	19830		
40				20	18020	15030	47	18510	15550		
45							40	15230	12550		
50							32	12750	10320		
55							21	10810	8590		
				1080 LBS			690 LBS			STOWED JIB	
				3050 LBS			2680 LBS			ERECTED JIB (RETRACTED)	
				3470 LBS			2950 LBS			ERECTED JIB (EXTENDED)	

LOAD RADIUS (FT)	BOOM LENGTH 80 FT (C)			BOOM LENGTH 96 FT (D)			DEDUCTIONS FOR JIB FROM MAIN BOOM CAPACITIES				
	LOADED BOOM ANGLE (DEG)	CODE 1 OVER REAR (LBS)	CODE 3 FULL 360° (LBS)	LOADED BOOM ANGLE (DEG)	CODE 1 OVER REAR (LBS)	CODE 3 FULL 360° (LBS)					
20	74	27500	27500								
25	70	24300	24300	75	18000	18000					
30	66	21280	21280	72	17500	17500					
35	62	19050	19050	69	16240	16240					
40	58	16980	15820	65	14660	14660					
45	53	15250	12810	62	13280	12970					
50	49	13000	10580	58	12130	10730					
55	44	11070	8860	54	11080	9020					
60	38	9530	7500	50	9680	7650					
65	31	8260	6380	46	8420	6540					
70	22	7200	5450	41	7360	5620					
75				36	6470	4840					
80				30	5700	4170					
85				23	5020	3580					
90				8	4410	3050					
				410 LBS			350 LBS			STOWED JIB	
				2420 LBS			2360 LBS			ERECTED JIB (RETRACTED)	
				2580 LBS			2490 LBS			ERECTED JIB (EXTENDED)	

**USE THIS CHART ONLY WHEN
ALL OUTRIGGER BEAMS ARE
IN THE MID POSITION**

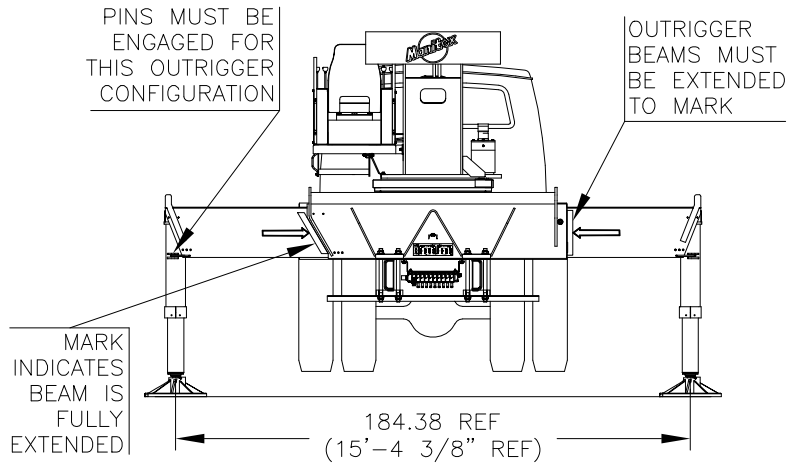

MAIN BOOM LIFTING CAPACITIES

LMI CODE 4											
LOAD RADIUS (FT)	BOOM LENGTH 30.5 FT		BOOM LENGTH 48 FT (A)		BOOM LENGTH 64 FT (B)		BOOM LENGTH 80 FT (C)		BOOM LENGTH 96 FT (D)		
	LOADED BOOM ANGLE (DEG)	FULL 360° (LBS)	LOADED BOOM ANGLE (DEG)	FULL 360° (LBS)	LOADED BOOM ANGLE (DEG)	FULL 360° (LBS)	LOADED BOOM ANGLE (DEG)	FULL 360° (LBS)	LOADED BOOM ANGLE (DEG)	FULL 360° (LBS)	
6	69	100000									
8	65	90400									
10	61	80000	73	51000							
12	56	71800	70	51000							
15	49	45210	66	46860	73	40000					
20	34	24570	59	25890	69	26420	74	26730			
25			52	17020	64	17480	70	17740	75	17920	
30			44	12110	59	12540	66	12780	72	12940	
35			34	8980	53	9400	62	9630	69	9780	
40			20	6780	47	7230	58	7450	65	7590	
45					40	5640	53	5860	62	5990	
50					32	4410	49	4640	58	4770	
55					21	3430	44	3670	54	3810	
60							38	2890	50	3020	
65							31	2230	46	2380	
70							22	1680	41	1830	
75									36	1360	
80											
	1080 LBS		690 LBS		520 LBS		410 LBS		350 LBS		DEDUCTIONS FOR JIB FROM MAIN BOOM CAPACITIES
	3050 LBS		2680 LBS		2520 LBS		2420 LBS		2360 LBS		STOWED JIB
	3470 LBS		2950 LBS		2720 LBS		2580 LBS		2490 LBS		ERECTED JIB (RETRACTED)
											ERECTED JIB (EXTENDED)

**USE THIS CHART WHEN ALL
OUTRIGGER BEAMS ARE NOT IN
EITHER THE MID OR FULLY
EXTENDED POSITION**

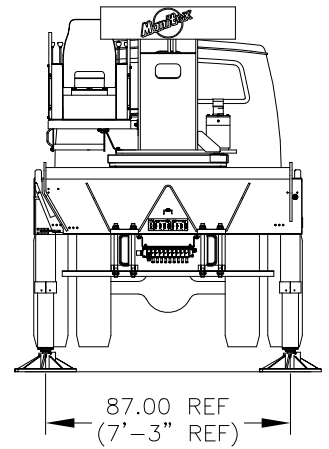

MAIN BOOM LIFTING CAPACITIES

LMI CODE 5										
LOAD RADIUS (FT)	BOOM LENGTH 30.5 FT		BOOM LENGTH 48 FT (A)		BOOM LENGTH 64 FT (B)		BOOM LENGTH 80 FT (C)		BOOM LENGTH 96 FT (D)	
	LOADED BOOM ANGLE (DEG)	FULL 360° (LBS)	LOADED BOOM ANGLE (DEG)	FULL 360° (LBS)	LOADED BOOM ANGLE (DEG)	FULL 360° (LBS)	LOADED BOOM ANGLE (DEG)	FULL 360° (LBS)	LOADED BOOM ANGLE (DEG)	FULL 360° (LBS)
6	69	83880								
8	65	43110								
10	61	27900	73	29260						
12	56	19950	70	21140						
15	49	13250	66	14310	73	14740				
20	34	7480	59	8470	69	8860	74	9080		
25			52	5360	64	5720	70	5930	75	6070
30			44	3410	59	3770	66	3970	72	4100
35			34	2070	53	2440	62	2630	69	2760
40			20	1070	47	1470	58	1660	65	1780
	1080 LBS		690 LBS		520 LBS		410 LBS		350 LBS	
	STOWED JIB									

DEDUCTIONS FOR JIB FROM
MAIN BOOM CAPACITIES

WARNINGS

1. THE JIB MUST BE IN THE STOWED POSITION, IF SO EQUIPPED, WHEN USING THIS OUTRIGGER CONFIGURATION.

**USE THIS CHART
WHEN PICKING
LOADS ON TIRES**

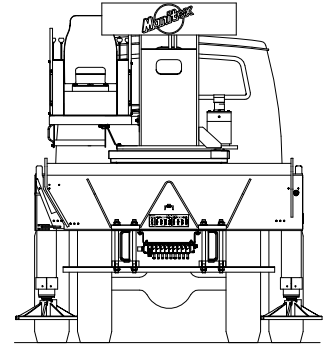

ON TIRE CAPACITIES

WARNINGS

LMI CODE 6			
LOAD RADIUS (FT)	MAX BOOM LENGTH (FT)	BOOM DIRECTLY OVER REAR (LBS)	STOWED JIB DEDUCTION (LBS)
10	30.5	12000	1080
12	30.5	11000	1080
15	30.5	9500	1080
20	48 (A)	7500	690
25	48 (A)	5000	690
30	48 (A)	3500	690
35	48 (A)	2500	690
40	48 (A)	1600	690

1. CRANE LOAD RATINGS ON TIRES ARE BASED ON THE CRANE BEING LEVEL AND TRAVELING ON A FIRM UNIFORM SURFACE (BLACK TOP, CONCRETE OR SIMILAR SURFACE).
2. TIRES MUST BE INFLATED TO 120 PSI FOR PICKING ON TIRES. CONSULT TRUCK MANUAL FOR PROPER INFLATION PROCEDURE.
3. THE JIB MUST BE IN THE STOWED POSITION, IF SO EQUIPPED, WHEN PICKING ON TIRES.
4. WHEN LIFTING ON TIRES, THE BOOM MUST BE CENTERED OVER THE REAR OF THE CRANE WITH THE SWING BRAKE AND THE HOUSELOCK ENGAGED.
5. KEEP THE LOAD CLOSE TO THE GROUND AND RESTRAINED FROM SWINGING.
6. WHEN THE RADIUS IS BETWEEN LISTED VALUES, USE THE SMALLER OF THE TWO LOAD RATINGS.
7. DO NOT OPERATE AT LONGER RADII THAN THOSE LISTED ON THE LOAD CHART.

**USE THIS CHART ONLY WHEN
ALL OUTRIGGER BEAMS ARE
FULLY EXTENDED**

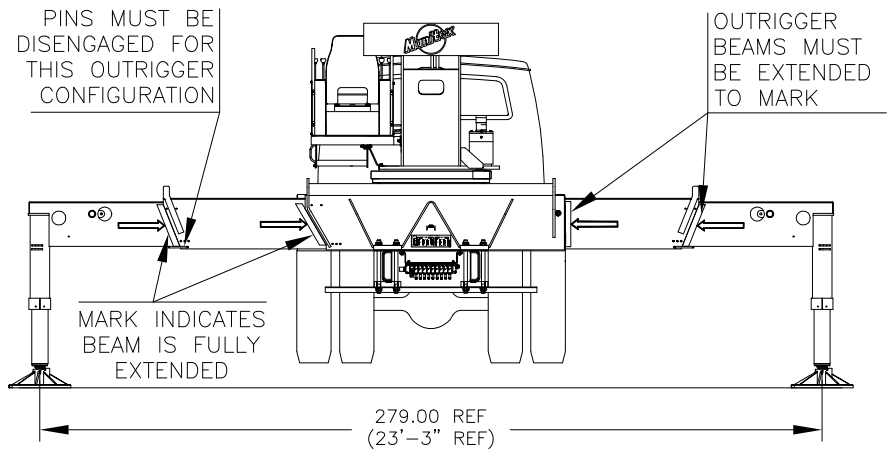

32 FT RETRACTED JIB LIFTING CAPACITIES

LOAD RADIUS (FT)	LOADED BOOM ANGLE (DEG)	0' OFFSET		15' OFFSET			30' OFFSET		
		CODE 7 OVER REAR (LBS)	CODE 8 FULL 360° (LBS)	LOADED BOOM ANGLE (DEG)	CODE 9 OVER REAR (LBS)	CODE 10 FULL 360° (LBS)	LOADED BOOM ANGLE (DEG)	CODE 11 OVER REAR (LBS)	CODE 12 FULL 360° (LBS)
40	73	8500	8500						
45	71	8320	8320	74	7600	7600			
50	68	7790	7790	72	7140	7140	74	5900	5900
55	66	7290	7290	69	6700	6700	72	5700	5700
60	63	6830	6830	66	6280	6280	69	5520	5520
65	61	6380	6380	64	5900	5900	66	5350	5350
70	58	5980	5650	61	5550	5550	63	5200	5200
75	55	5610	4850	58	5240	5200	60	5000	5000
80	52	5270	4180	55	4960	4480	57	4760	4720
85	49	4970	3590	52	4700	3860	54	4540	4060
90	46	4410	3080	49	4460	3310	51	4330	3480
95	42	3890	2630	45	4080	2830	47	4150	2970
100	38	3420	2220	41	3590	2400	43	3700	2510
105	34	3010	1870	37	3150	2010	38	3220	2090
110	29	2630	1540	32	2740	1650	32	2780	1700
115	23	2290	1250	25	2360	1320	24	2360	1320
120	14	1980	980	14	2000	1000			

**USE THIS CHART ONLY WHEN
ALL OUTRIGGER BEAMS ARE
FULLY EXTENDED**

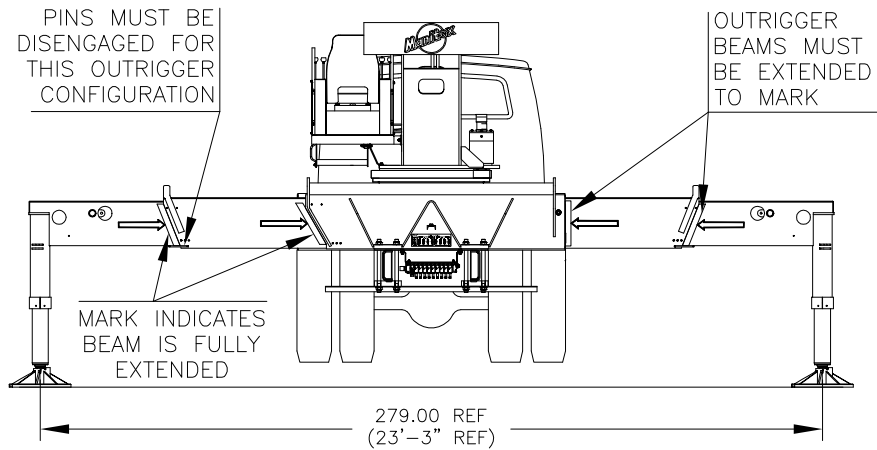

49 FT EXTENDED JIB LIFTING CAPACITIES

LOAD RADIUS (FT)	LOADED BOOM ANGLE (DEG)	0° OFFSET		15° OFFSET			30° OFFSET		
		CODE 13 OVER REAR (LBS)	CODE 14 FULL 360° (LBS)	LOADED BOOM ANGLE (DEG)	CODE 15 OVER REAR (LBS)	CODE 16 FULL 360° (LBS)	LOADED BOOM ANGLE (DEG)	CODE 17 OVER REAR (LBS)	CODE 18 FULL 360° (LBS)
45	73	5600	5600						
50	71	5600	5600	75	4530	4530			
55	69	5600	5600	73	4300	4300			
60	67	5300	5300	71	4080	4080	75	3350	3350
65	65	4960	4960	69	3900	3900	73	3230	3230
70	63	4670	4670	67	3710	3710	71	3120	3120
75	61	4400	4400	65	3550	3550	68	3020	3020
80	58	4160	4160	62	3410	3410	66	2930	2930
85	55	3940	3940	60	3270	3270	63	2850	2850
90	53	3730	3670	57	3150	3150	60	2770	2770
95	50	3550	3210	54	3030	3030	57	2710	2710
100	47	3380	2800	51	2930	2930	54	2650	2650
105	44	3230	2440	48	2830	2710	51	2600	2600
110	41	3090	2110	45	2750	2350	48	2550	2530
115	38	2850	1820	42	2670	2030	44	2520	2170
120	34	2540	1550	38	2600	1730	40	2510	1830
125	30	2260	1310	33	2400	1450	34	2460	1520
130	25	1990	1080	28	2100	1180	27	2110	1200
135	18	1750	870	20	1800	930			

**USE THIS CHART ONLY WHEN
ALL OUTRIGGER BEAMS ARE
IN THE MID POSITION**

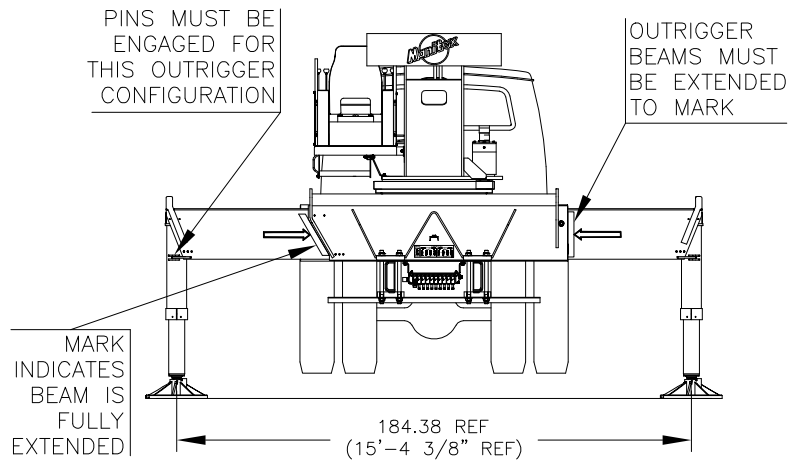

32 FT RETRACTED JIB LIFTING CAPACITIES

LOAD RADIUS (FT)	0° OFFSET		15° OFFSET		30° OFFSET	
	LOADED BOOM ANGLE (DEG)	CODE 19 FULL 360° (LBS)	LOADED BOOM ANGLE (DEG)	CODE 20 FULL 360° (LBS)	LOADED BOOM ANGLE (DEG)	CODE 21 FULL 360° (LBS)
40	73	7640				
45	71	6000	74	6670		
50	68	4740	72	5320	74	5830
55	66	3760	69	4260	72	4700
60	63	2960	66	3400	69	3780
65	61	2300	64	2690	66	3010
70	58	1740	61	2090	63	2370
75	55	1270	58	1570	60	1820
80	52	860	55	1130	57	1340
85					54	920

49 FT EXTENDED JIB LIFTING CAPACITIES

LOAD RADIUS (FT)	0° OFFSET		15° OFFSET		30° OFFSET	
	LOADED BOOM ANGLE (DEG)	CODE 22 FULL 360° (LBS)	LOADED BOOM ANGLE (DEG)	CODE 23 FULL 360° (LBS)	LOADED BOOM ANGLE (DEG)	CODE 24 FULL 360° (LBS)
45	73	5600				
50	71	5400	75	4530		
55	69	4390	73	4300		
60	67	3580	71	4080	75	3350
65	65	2910	69	3490	73	3230
70	63	2340	67	2870	71	3120
75	61	1860	65	2340	68	2750
80	58	1450	62	1870	66	2240
85	55	1090	60	1470	63	1790
90			57	1120	60	1400
95					57	1050