

P&H[®] ΩMEGA[®]-25

25-ton Rough Terrain Crane 134-ft. (40.8m) maximum tip height



THE ULTIMATE IN PERFORMANCE, SERVICEABILITY, ECONOMY

- **Excellent reach** afforded by telescoping 80 ft. (24.4 m) 3 section full power boom. Add 30 ft. (9.1 m) lattice boom extension and 20 ft. (6.1 m) jib for total length of 130 ft. (39.6 m).
- **Telescope rated loads** for precise placement. Semi-fixed cylinder mounts decrease cylinder deflection under load and increase telescoping capacity.
- **Superior lifting performance** provided by rectangular full depth four-plate OMEGA boom that is welded inside and out.
- **Industry's most maneuverable RT crane** — four wheel drive/steer OMEGA with coordinated steering has shortest turning radius and lowest travel height.
- **Turbocharged engine** offers low sound levels, low fuel consumption, excellent high altitude performance and superior torque for optimum horsepower usage.
- **A duty-cycle machine** — OMEGA's powerful winches offer high line speeds, and pull. VOLUMATIK[®] hydraulic system provides optimum oil flow for fast crane functioning.
- **Total operator comfort** means less fatigue and greater production. Spacious OMEGA cab module allows placement of controls "in the palm of your hand", lots of leg and elbow room, and full vision of all activities.
- **Less downtime** — OMEGA is "Pit-Stop" maintenance-proven. It's industry's most serviceable crane — engineered for parts commonality, accessibility and fast tear-down.

Specifications

specifications

BOOM



BOOM: All boom sections are of full depth rectangular four-plate construction welded inside and out, with adjustable nylon-slider pads on top, bottom and sides. All powered sections are hydraulically self-proportioning, single lever controlled. Semi-fixed telescope cylinder mounts provide capacity to telescope rated loads. Boom point contains three 15" (381 mm) P.D. main sheaves and one 15" (381 mm) P.D. idler sheave. Sheaves are non-metallic with roller bearings.

Three (3) section boom, 32' (9.8 m) retracted length, 80' (24.4 m) extended length, consisting of one base section and 2 powered sections.

BOOM EXTENSION (OPTIONAL): 30' (9.1 m) swing-around tapered lattice structure with single 15" (381 mm) P.D. metallic boom point sheave with roller bearing. Easily installed from ground level by pivoting from its stored position on right side of boom base and pin connecting to boom point. For extending reach of boom.

JIB (OPTIONAL): 20' (6.1 m) underslung A-frame structure with single 15" (381 mm) P.D. metallic jib point sheave with bronze bushing, compression strut and guy cables. Pin and guy line connected. For extending reach of extension.

AUXILIARY SHEAVE (OPTIONAL): Single metallic sheave 11.25" (286 mm) P.D. with bronze bushing, bracket-mounted on boom point, for use with single auxiliary winch line.

HOOK BLOCKS (OPTIONAL).

- A) 25 Ton — 3 sheaves with swivel hook and safety latch, for 5/8" (15.9 mm) wire rope.
- B) 10 Ton — 1 sheave with swivel hook and safety latch, for 1/2" (12.7 mm) or 5/8" (19mm) wire rope.
- C) 8.5 Ton — weighted hook with swivel and safety latch, for 1/2" (12.7 mm) wire rope.

UPPERSTRUCTURE



OPERATOR'S CAB: All-weather environmental cab of steel has hinged ceiling window, slide-by right side window with guard, locking slide-by door and large windows with full view in all directions. Safety glass used throughout. Operator's four-way adjustable seat has torsion suspension. Cab is 34.5 inches (876 mm) wide with a stand-up height of 56 inches (1422 mm) and is cushion-mounted for vibration dampening and noise reduction.

CAB ACCESSORIES (STANDARD): Cab contains all roading and crane function controls in addition to electric remote control of outriggers, mechanical boom angle indicator and boom length indicator on boom base, and electronic anti-two block device.

CAB ACCESSORIES (OPTIONAL): Heater (diesel or propane fueled, thermostatically controlled), defroster fan, electric roof window wiper, seat belt, fire extinguisher, electronic boom angle indicator, electric boom length indicator, electric load indicating device, drum rotation indicators for auxiliary and main winches, 360° house lock, tinted glass, vandalproof glass (lexan), electric warning horn, windshield wiper, windshield washer, air conditioner, amber rotating beacon, foot operated caliper disc swing brake, rear steer centering light, and rear view mirrors (both sides).



CONTROLS: In front of operator are foot pedals for boom hoist, swing brake (opt.), service brakes, and engine throttle. Left of steering wheel are console mounted double-acting levers for swing (with optional horn button) and telescope. At the right are levers for auxiliary winch (optional), main winch, and boom hoist. Also in front of operator are rear steer centering light (optional), axle lockout override button (optional), main winch speed indicator and engine starting aid switch. On right side of seat are floor mounted levers for house lock and swing holding brake. Drum rotation indicators (optional) are mounted on auxiliary and main winch levers and a directional indicator (emergency flasher) switch on steering column. At operator's right are console mounted switches for master ignition, steering mode, parking brake, windshield wiper (optional), master lights (optional), defroster (optional), hi-low transmission range, and outrigger controls. Also on console are engine start button, warning light and buzzer monitoring power plant gauge panel, engine stop button, dash light, cigarette lighter, fuel gauge, air pressure

gauge, circular level, gear selector lever, forward-reverse selector lever and positive (air) hand throttle. Console has prewired removable modules for ease of service.

OTHER CONTROLS: Located elsewhere are — Power plant gauge panel (rear of engine compartment) with gauges for hydraulic oil temperature, engine oil pressure, engine water temperature, torque converter oil temperature, transmission clutch oil pressure, volt meter and hour meter, hydraulic axle oscillation lockouts on rear axle cradle, pump disconnect lever on pump drive housing and front axle disconnect is automatic when transmission is shifted into high range.

COUNTERWEIGHT: 7,082 lb. (3212 kg) with main winch only. 6,115 lb. (2773.7 kg) with both main and auxiliary winches.



MAIN WINCH: P&H 1580 two speed, mounted on rear of revolving frame. Planetary gearing with equal speed power raising and lowering. Infinitely variable controlled speed. Spring applied, hydraulically released load holding multiple disc brake is automatic. Complete with 450' (137 m) wire rope.

Drum: 14.875" (378 mm) P.D. x 18.5" (470 mm) wide with 22.25" (565 mm) dia. flanges.

Wire Rope: 5/8" (16 mm) dia. 8 x 19 spin resistant, extra improved plow steel with 7 x 7 I.W.R.C.

Drum Capacity: 639 ft. (195 m) 5 layers.

Line Pull (Max.): 14,875 lb. (6741 kg) 1st layer (low speed).

Line Pull (Permissible): 8,600 lb. (3924 kg) per part of line.

Line Speed Up (Maximum):

High speed - 487 fpm (148 m/m) 5th layer (high speed).

AUXILIARY WINCH (OPTIONAL): P&H 1580 see above.

AUXILIARY WINCH (OPTIONAL): P&H 1080 single speed mounted on counterweight. Planetary gearing with equal speed power raising and lowering. Infinitely variable controlled speed. Spring applied, hydraulically released load holding multiple disc brake is automatic. Complete with 360' (110 m) wire rope and additional boom point idler sheave.

Drum: 11.25" (286 mm) P.D. x 16.5" (419 mm) wide with 16.75" (425 mm) dia. flanges.

Wire Rope: 1/2" (12.5 mm) dia. 8 x 19 spin resistant, extra improved plow steel with 7 x 7 I.W.R.C.

Drum Capacity: 543 ft. (165 m) 5 layers.

Line Pull (Max.): 10,500 lb. (4761 kg) 1st layer.

Line Pull (Permissible): 6,200 lb. (2812 kg) per part of line.

Line Speed Up (Maximum):

High speed - 360 fpm (110 m/m) 5th layer.



BOOM HOIST: One 9" (229 mm) I.D. cylinder, double-acting. Hydraulically powered raising and lowering with holding valve.

BOOM TELESCOPE: Two 5.75" (146 mm) I.D. cylinders — double acting. Hydraulically powered extending and retracting with holding valve. Supplied by a single hose loop.

VOLU-MATIK® HYDRAULIC SYSTEM: This system utilizes 4 pumps and is designed to provide ample volume and pressure for optimum performance. The pumps are gear driven from two PTO's located on rear of engine torque converter.

The left hand main tandem gear pump, at 2500 rpm (engine full load), provides 27.5 gpm (104 lpm) to the main and/or auxiliary winch boost and steering circuits and 24 gpm (91 lpm) to the swing or outrigger circuits.

The right hand tandem gear pump, at 2175 rpm (corresponding to full load) provides 53 gpm (200 lpm) to the main and/or auxiliary winch circuits and 37.5 gpm (142 lpm) to the boom hoist and telescope circuits. This pump is furnished with a manual disconnect. Linkage extends through engine housing for easy accessibility.

Total flow for this system at governed engine speed is 142 gpm (537 lpm). High pressure oil leaving the pump to the swing, steer and outrigger circuits is filtered to 20 microns to protect seals in cylinders, valves and motors, before entering the functioning circuits. All returning oil (100%) is filtered in a bypass type filter to 10 microns before entering the reservoir.

The 124 gal. (469 liter) reservoir is located on the right side of carrier. Pumps, valves, cylinders and motors are readily accessible and easy to service. Control valves are four way, three position type with low effort spools and pilot-operated relief valves for quick smooth response. A single spool pressure compensated valve is used for swing metering control. Cable linkage connects valves to control levers. Air to oil cooler is standard.



SWING UNIT: Hydraulic motor driving through 36:1 planetary gear reducer to pinion gear. 360° continuous rotation to 3.13 RPM.

SWING GEAR: External cut spur gear with 136 teeth 45.3" (1151 mm) P.D. Dust cover is available (optional).

SWING BRAKE: STANDARD — Multiple disc brake integral with swing gear reducer, manually engaged with swing brake lever and hydraulically released by swing lever engagement. OPTIONAL — Caliper disc brake mounted on swing gear reducer, manually applied with swing brake pedal for slow dynamic stopping and swing brake lever for static holding. Hydraulically released by swing lever engagement.

HOUSE LOCK: Two position (front and rear) pin-in-hole lock manually engaged with house lock lever in cab. A positive 360° position lock is available (optional).

ROTARY MANIFOLD: Sealed rotary swivel for air and hydraulic hose connections between rotating upper and carrier. Quickly removable from above or below for servicing. Electrical swivel is mounted on top of air and hydraulic swivel.

FASTENING TO LOWER: Single row ball bearing integral with swing gear. Bolted to carrier frame and bolted to rotating frame. Bearing is protected from dust by labyrinth seal.



CARRIER

4 x 4 x 4

(Four wheels drive. Four wheels steer).

FRAME: All-welded unitized construction assures rigidity and permanent alignment of swing bearing and rotating upper machinery. Fabricated of rectangular tubing main frame beams of high strength 46,000 psi minimum yield alloy steel and reinforced with rectangular box cross members of high strength alloy steel.



HYDRAULIC OUTRIGGERS: Four (4) independent assemblies that hydraulically extend out horizontally from carrier frame and down vertically to form a stable working platform. Four (4) double acting hydraulic cylinders provide independent horizontal beam movement and four (4) provide vertical rod movement. Vertical cylinders are equipped with holding valves. Cylinders are actuated by electric solenoid directional control valves operated from cab console switches.

OUTRIGGER BEAMS: Fabricated high strength alloy steel box extending to a maximum of 8'11" (2.7 m) from center of carrier.

OUTRIGGER FLOATS: Removable floats with storage on outrigger box. Float size 19.25" (489 mm) square.



STEERING: Front and rear axle steer — pressure compensated hydrostatic power system fully controlled by steering wheel for front and rear axles. Two wheel, four wheel and crab steering modes are selected by 3 position toggle switch located in cab on side console. Center position of switch locks position of rear wheels and only front wheels are steerable.

FRONT AXLE: Rockwell PSM 824 steer and drive axle driven through differential with planetary in hubs. Total reduction 16.65:1. Axle is rigid mounted and has power steering. Front axle is disconnected automatically for highway travel when transmission is in high range.

REAR AXLE: Rockwell PSM 824 steer and drive axle driven through differential with planetary in hubs. Power steering. No-spin differential (optional). Axle is pivot mounted with automatic hydraulic lockout cylinders to prevent oscillation (vertical movement of axle). Total oscillation attainable is 8 in. (203 mm) at center of tires.

SERVICE BRAKES: Air over hydraulic brakes on all four wheels. Dual shoe type brakes. Drum dia. 17.25" (438 mm). Shoe width 4" (102 mm).

PARKING BRAKES: Maxi spring set air chamber on 12.5" dia. (318 mm) transmission output shaft disc brake. Spring applied and air released for safety.

TIRE OPTIONS:

Std. — 16.00 x 25 — 24 ply tubeless earthmover Sure Grip (E-3).

Opt. — 20.50 x 25 — 20 ply tubeless Sure Grip lug wide base (E-2).



STANDARD POWER PLANT:

ENGINE

Model	Detroit Diesel 4-53T
Type	Diesel — direct injection
No. of cylinders	4
Cycle	2
Bore x Stroke, in. (mm)	3.875 x 4.50 (99 x 114)
Displacement, cu. in.	212
	Liters
	3.5
Air Induction	Turbo-charged
Air Cleaner	2 stage dry type, replaceable element
Oil Filter	Fullflow with replaceable element
Fuel Filter	Fullflow with replaceable element
Fuel Tank	50 gal. (189.3 liters) FHWA approved (Left side of carrier)
Cooling	Liquid-pressurized, recirculating by-pass
Radiator	Fin and tube core, thermostat controlled
Fan	6 Blade, suction type, 22 in. (560 mm) dia.
Starting	12 volt motor
Charging	12 volt - 42 amp alternator, negative ground
Battery	210 amp. hour, Voltmaster, Type H8D
Compressor, air	12 CFM @ 1250 RPM
Governor, air	105-120 PSI
Horsepower, Gross	155 (116 Kilowatts) @ 2500 RPM



OPTIONAL POWER PLANT

ENGINE

Model	Deutz Model BF6L-913
Type	Diesel - direct injection
No. of cylinders	6
Cycle	4
Bore x Stroke, in. (mm)	4.02 x 4.92 (102 x 125)
Displacement, cu. in.	373.5
	Liters
	6.12
Air Induction	Turbo-charged
Air Cleaner	2-stage dry type - replaceable element
Oil Filter	Fullflow with replaceable element
Fuel Filter	Fullflow with replaceable element
Fuel Tank	50 gal. (189 liters) FHWA approved (Left side of carrier)
Cooling	Air — 3.389 CFM air flow
Starting	12 volt motor
Charging	12 volt - 72 amp. alternator, negative ground
Battery	210 amp. hour
Compressor, air	12 CFM @ 1250 RPM
Governor, air	105-120 PSI
Horsepower, Gross	157 (117 Kilowatts) @ 2500 RPM



TRANSMISSION

Model	Funk Model 1028E
Type	Powershift with 12.75 in. (324 mm) torque converter, 6 speeds equal forward and reverse, with high-low range shift. Electrically controlled, pneumatically operated gear shift. Neutral safety start.

PUMP DRIVES: Gear driven integral with transmission off rear of torque converter housing. Left hand pump drive for winch boost/steer and swing/outriggers. Right hand pump drive for winch and boom hoist/telescope. Left hand direct drive ratio and right hand 1:0.87 reduction. Right hand drive equipped with manual disconnect

LOWER EQUIPMENT (STANDARD): Engine hood, engine gauge panel with engine oil pressure, engine temperature, transmission clutch oil pressure, converter oil temp., hydraulic oil temp., hourmeter, voltmeter, front axle disconnect and hydraulic oil cooler.

LOWER EQUIPMENT (OPTIONAL): Fenders, tool box, engine starting aid, back up alarm, rear view mirrors, front bumper tow winch, pintle hook front and rear. Highway lights, directional signals and stop lights, no spin rear axle, swing gear cover, sound reduction package, alcohol evaporator and air dryer.

OTHER EQUIPMENT (OPTIONAL): Auxiliary boom point sheave with mounting, oscillating axle override, valve bank cover, rear steer centering indicator in the cab and flood lights.

SPECIAL EUROPEAN OPTIONS: Winch spooling rollers, electrical load moment device with anti-two block, extra pass electrical collector ring, winch minimum rope wrap shut off, dual brakes.

PERMISSIBLE HOIST LINE LOAD IN POUNDS		
PARTS OF LINE	MAIN WINCH	AUXILIARY WINCH
1	8,600	6,200
2	17,200	12,000
3	25,800	—
4	34,400	—
5	43,000	—
6	50,000	—
HOIST LINE WIRE ROPE		
TYPE	5/8-8x19	1/2-8x19
BREAKING STRENGTH	36,200	23,400
PERMISSIBLE STRENGTH	10,343	6,686

SHEAVE AND DRUM TO WIRE ROPE RATIOS: (Pitch Diameter)

	Sheave to Wire Rope	Drum to Wire Rope
Boom Main Sheave	24 to 1	---
Boom Idler Sheave	24 to 1	---
Boom Ext. Sheave	24 to 1	---
Jib Sheave	24 to 1	---
Main Winch	---	18.2 to 1
Aux. Winch	---	20.25 to 1

dimensions

		TIRES	
		16.00 x 25	20.5 x 25
VEHICLE TURNING DIAMETER	-4-WHEEL STEER CRAMP	37' - 10-1/4" (11.53m)	38' - 2-3/4" (11.65m)
	-FRONT AXLE STEER	64' - 4-7/8" (19.63m)	64' - 9-1/2" (19.74m)
VEHICLE CLEARANCE DIAMETER	-4-WHEEL STEER CRAMP	47' - 11-1/4" (14.61m)	42' - 9-5/8" (13.04m)
	-FRONT AXLE STEER	69' - 4-3/4" (21.15m)	69' - 4-3/4" (21.15m)

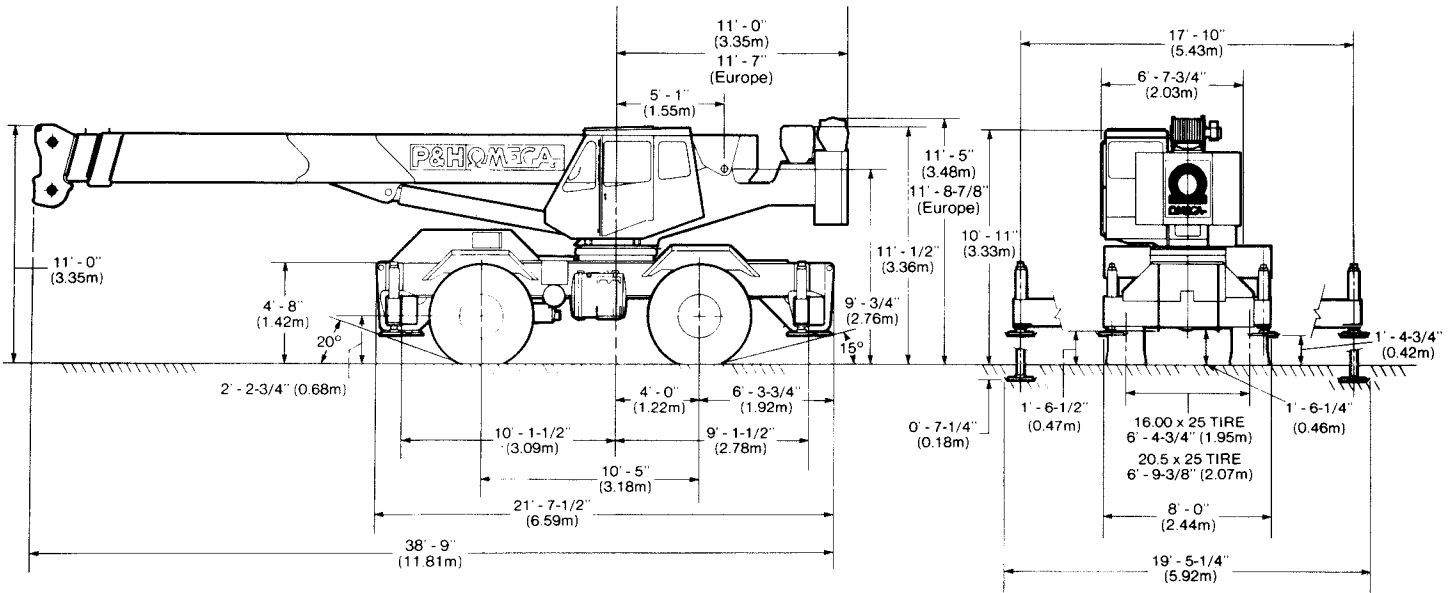

operating instructions

This P&H crane meets the requirements of ANSI B30.15 (1973). Boom structure (boom, lattice extension and jib) has been tested per SAE J1063, machine stability tested per SAE J765. LOAD RATINGS shown apply only to machine as originally manufactured and equipped by Harnischfeger Corporation.

WARNING: Operation of this machine in excess of rated loads, in areas of chart not rated, or with disregard of instructions voids this warranty.

- LOAD RADIUS is horizontal distance from axis of rotation (before loading) to center of vertical hoist line (after loading). Actual working radii should be an accurate measurement.
- Boom, lattice extension and jib point height dimensions are measured from ground to center of load sheave.
- LOADED BOOM ANGLE is the angle between the boom base section and the horizontal axis after lifting rated load at rated radius. Loaded boom angles shown are with rated loads applied and provide an **approximation** of the LOAD RADIUS at the specified BOOM LENGTH (includes lattice extension). The boom angle before loading should be slightly greater to account for boom deflection.
- LOAD RATINGS shown are for machine with counterweight as shown, leveled and standing on firm, uniform supporting surface. Ratings are based on freely suspended loads and are not more than 85% of minimum tipping loads. Ratings above the bold horizontal line are based on machine's hydraulic or structural competence and not on machine stability (tipping conditions).
- To determine LOAD RATINGS in-between those shown on chart, proceed as follows:
 - for boom lengths not shown, use rating of next longer rated boom;
 - for load radii not shown, use rating of next longer rated radius.
- Deduct weight from LOAD RATINGS of all suspended load handling devices such as hooks, hookblocks, slings, buckets, etc. as they are considered part of the load. See table for deductions.
- Deduct weight from LOAD RATINGS of fixed boom attachments (jib, boom extension) either stowed or erected, as they reduce capacity of boom. See table for deductions.
- LOAD RATINGS shown make no allowance for such factors as wind effect on lifted loads, ground conditions, out-of-level, operating speed or conditions that could be detrimental to safe operation of this machine. The operator must judge these factors and reduce ratings accordingly.
- "WITH OUTRIGGERS" LOAD RATINGS are based on outriggers fully extended and set at a distance of 8 ft. 11 in (2.72 m) from longitudinal axis of carrier to vertical axis of outrigger float. Machine must be level and supported by outriggers with tires free of supporting surface.
- "WITHOUT OUTRIGGERS" LOAD RATINGS are based on lift limitations and conditions of tires inflated to pressures shown in table, and apply only when rear axle lockouts are engaged. Over front "Pick and Carry" ratings are limited to travel speed less than 2½ mph (4 kmph) on firm, level ground with load centered over front of machine and load restrained from swinging.
- Maximum JIB LOAD RATINGS are based on structural competence. Ratings at any radius shall not exceed BOOM LOAD RATINGS at same radius and shall not exceed maximum ratings shown.
- Jibs are intended to increase lifting height — not load radius. Maximum JIB LOAD RADIUS shall not exceed maximum BOOM LOAD RADIUS of boom length on which jib is mounted.
- For bucket ratings on jib, deduct 20% from maximum JIB LOAD RATINGS.
- Method of powered boom extension is hydraulically synchronous with each section extendible a distance of 24 ft. 0 in. (7.32 m). Powered sections resynchronize when boom is fully retracted or extended.
- The maximum load which may be telescoped is limited by hydraulic pressure, boom angle and lubrication. It is safe to telescope any load within limits of load rating chart.

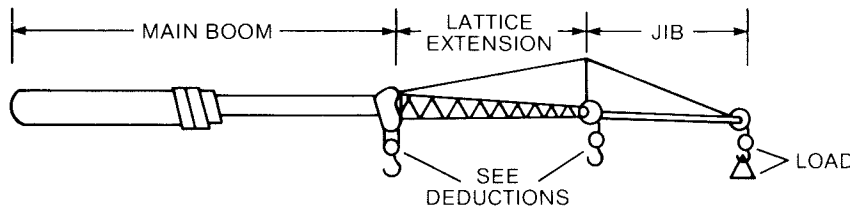

areas of operation

ON OUTRIGGERS

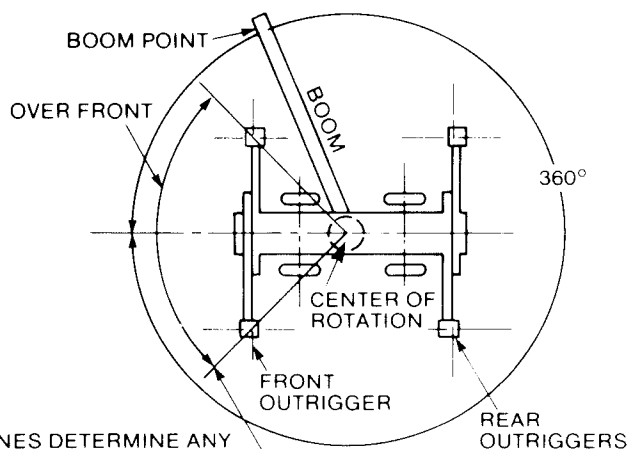

ON RUBBER

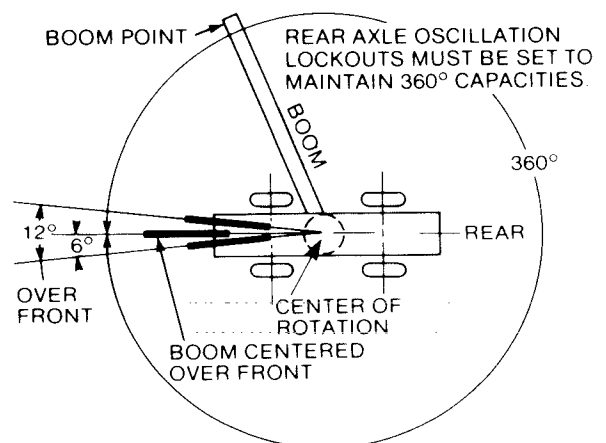

working ranges

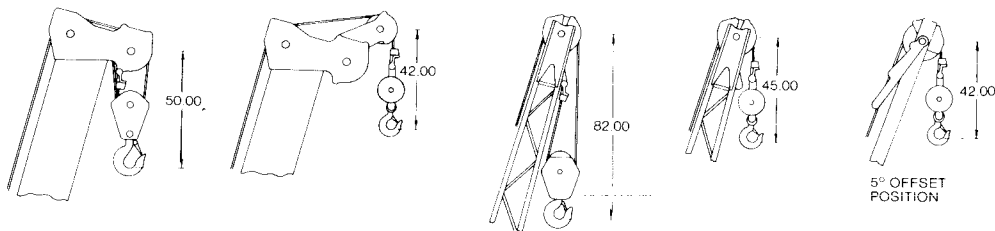
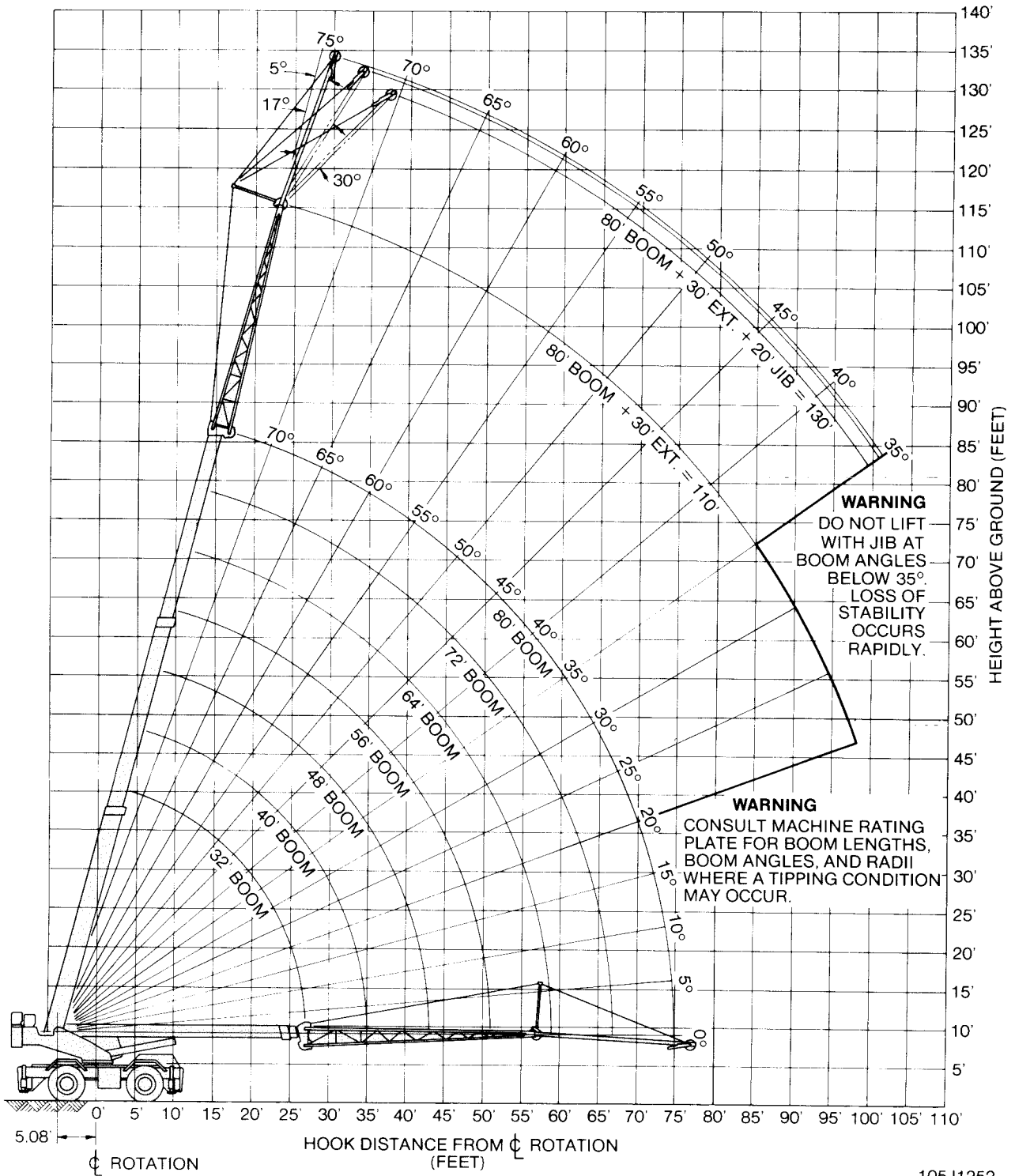

PCSA CLASS 12-100 three section full powered boom rated crane loads in pounds — boom in 360° and over front work areas

LOAD RADIUS (FEET)	BOOM LENGTH (IN FEET)																
	32'			40'			48'			56'			64'				
	LOADED BOOM ANGLE △°	RATED LOAD POUNDS		LOADED BOOM ANGLE △°	RATED LOAD POUNDS		LOADED BOOM ANGLE △°	RATED LOAD POUNDS		LOADED BOOM ANGLE △°	RATED LOAD POUNDS		LOADED BOOM ANGLE △°	RATED LOAD POUNDS			
		360°	Front		360°	Front		360°	Front		360°	Front		360°	Front		
10	66	50000	50000	71	50000	50000											
12	61	50000	50000	68	50000	50000	72	50000	50000	75	46000	46000					
15	55	43000	43000	63	43000	43000	68	43000	43000	72	43000	43000	74	35500 35500			
20	42	30000	30000	54	30000	30000	61	30000	30000	66	30000	30000	70	30000 30000			
25	24	22800	22800	44	22800	22800	54	22800	22800	60	22800	22800	65	22800 22800			
30				32	17200	18000	46	17200	18000	54	17200	18000	59	17200 18000			
35							36	13100	14400	47	13100	14400	54	13100 14400			
40							23	10000	11250	39	10000	11250	48	10000 11250			
45	CAUTION: FOR 32 FOOT BOOM LENGTH RATINGS, TELESCOPE CYLINDERS MUST BE FULLY RETRACTED AND AGAINST STOPS.									29	8200	8800	41	8200 8800			
50											13	6550	7300	33	6550 7300		
55				WARNING: Do not exceed rated load radius for a rated load.												22	5300 6050
60																	

WARNING: Main boom ratings must be reduced by weight of fixed boom attachments. See table.

32R502

“on rubber” rated crane loads in pounds — minimum boom (72' maximum)

RATED LOADS FOR 16.00 x 25 — 24 PLY TIRES					LOAD RADIUS (FEET)	RATED LOADS FOR 20.5 x 25 — 20 PLY TIRES				
STATIONARY			CREEP	2½ MPH		STATIONARY			CREEP	2½ MPH
BOOM CENTERED OVER FRONT	± 6° ARC OVER FRONT	360° ARC	BOOM CENTERED OVER FRONT			BOOM CENTERED OVER FRONT	± 6° ARC OVER FRONT	360° ARC	BOOM CENTERED OVER FRONT	
44400	40400	24200	34700	28100	10	40000	36700	22300	31100	21700
38200	34500	19600	29700	23900	12	34400	31300	18700	26500	18300
31300	28000	13600	24100	19200	15	28100	25300	13600	21500	14500
19200	19200	8200	17800	14100	20	18400	18400	8200	15800	10300
12800	12800	5200	12800	10700	25	13100	13100	5600	12100	7600
9400	9400	3400	9400	8400	30	9500	9500	3600	9500	5700
7000	7000	2400	7000	6600	35	6900	6900	2400	6900	4400
5100	5100	1400	5100	5100	40	5200	5200	1600	5200	3200
3900	3900	—	3900	3900	45	4000	4000	—	4000	—
2900	2900	—	—	—	50	2900	2900	—	—	—
2100	2100	—	—	—	55	2100	2100	—	—	—

32U1350

**WARNING: DO NOT EXCEED MAXIMUM RADIUS SHOWN OR
A TIPPING CONDITION WILL OCCUR.**

32U1353

LOAD RATINGS WITHOUT OUTRIGGERS DEPEND ON TIRE CAPACITY AND CONDITION, INFLATED PER TABLE, AND APPLY ONLY WHEN REAR AXLE LOCKOUTS ARE ENGAGED.

TIRE INFLATION (PSI)				
SIZE	STAT.	CREEP	2½ MPH	ROADING
20.5x25-20 PR	80	80	65	50
16.00x25-24 PR	100	100	95	75

with lattice extension

with outriggers fully extended and set

BOOM LENGTH (IN FEET)						LATTICE EXTENSION			LOAD RADIUS (FEET)
72'			80'			110'			
LOADED BOOM ANGLE Δ°	RATED LOAD POUNDS		LOADED BOOM ANGLE Δ°	RATED LOAD POUNDS		LOADED BOOM ANGLE Δ°	RATED LOAD POUNDS		
	360°	Front		360°	Front		360°	Front	
									10
RATINGS ABOVE THE HEAVY LINE ARE BASED ON STRUCTURAL COMPETENCE AND NOT ON MACHINE STABILITY.									12
									15
72	27000	27000	75	25000	25000				20
68	22800	22800	71	21000	21000				25
64	17200	17500	67	17200	17200	73	12000	12000	30
59	13100	14400	63	13100	14400	71	10700	10700	35
54	10000	11250	58	10000	11250	68	9800	9800	40
48	8200	8800	54	8200	8800	65	8100	8100	45
42	6550	7300	49	6550	7300	62	7300	7300	50
36	5300	6050	44	5300	6050	59	6400	7100	55
28	4400	5000	38	4400	5000	56	5200	6050	60
			31	3700	4200	52	4500	5000	65
			22	3050	3250	49	3700	4250	70
			11	2500	2850	46	3100	3700	74
						41	2500	3100	80
						37	2050	2600	85
						32	1700	2200	90
						26	1400	1800	95
						19	1150	1400	100

WARNING

FOR BOOM LENGTHS LESS THAN 110 FEET WITH BOOM EXTENSION ERECTED. THE RATED LOADS ARE DETERMINED BY BOOM ANGLE ONLY IN THE COLUMN HEADED BY 110 FOOT BOOM. FOR BOOM ANGLES NOT SHOWN, USE RATING OF NEXT LOWER BOOM ANGLE.

32R502

WHEN LIFTING A LOAD, ALL POWERED SECTIONS OF THE BOOM MUST BE EXTENDED EQUALLY.

TO HELP PREVENT TIPPING CONDITIONS WHEN "LIFTING ON RUBBER", IT IS RECOMMENDED THAT —

1. MINIMUM BOOM LENGTHS BE USED, NOT EXCEEDING 72 FEET.
2. OUTRIGGERS BE EXTENDED AS FAR AS POSSIBLE AND CLEAR OF GROUND.

WHEN TRANSPORTING A LOAD, MACHINE MUST BE ON FIRM, LEVEL SURFACE WITH MECHANICAL HOUSELOCK ENGAGED AND LOAD CENTERED OVER FRONT OF MACHINE AND RESTRAINED FROM SWINGING. DO NOT EXCEED 2½ MPH (4 KMPH) VEHICLE SPEED.

CREEP IS MOTION FOR LESS THAN 200 FT. IN A 30 MIN. PERIOD & NOT EXCEEDING 1 MPH.

STABILITY RATINGS DO NOT EXCEED 85% OF TIPPING LOADS WITH AUXILIARY SHEAVE ON BOOM POINT AND STOWED BOOM EXTENSION.

"WITHOUT OUTRIGGER" LIFTS WITH JIB OR BOOM EXTENSION IN WORKING POSITION ARE PROHIBITED.

MAXIMUM LOAD RATINGS IN POUNDS			
Minimum Boom Angle	JIB ANGLE OFFSET		
	5°	17°	30°
75°	6200	6000	5100
70°	6000	5000	4500
65°	5000	4500	4000
60°	3800	3500	3500
55°	3100	3000	3000
50°	2400	2300	2300
45°	1900	1800	1800
40°	1400	1300	1300
35°	1000	1000	1000

Jib ratings

1. MAXIMUM JIB LOAD RATINGS ARE BASED ON STRUCTURAL COMPETENCE AND DO NOT EXCEED 85% OF TIPPING LOAD WITH FULLY EXTENDED OUTRIGGERS. USE OF OUTRIGGERS IS REQUIRED WHEN BOOM IS EQUIPPED WITH JIB.
2. FOR BUCKET RATINGS ON JIB, DEDUCT 20% FROM MAXIMUM JIB LOAD RATINGS.
3. **WARNING:** DO NOT LIFT WITH JIB AT BOOM ANGLES BELOW 35°. LOSS OF STABILITY OCCURS RAPIDLY.
4. **WARNING:** DO NOT EXCEED 101 FOOT OPERATING RADIUS WITH ERECTED JIB OR A TIPPING CONDITION WILL OCCUR.

deductions to be made from rated loads

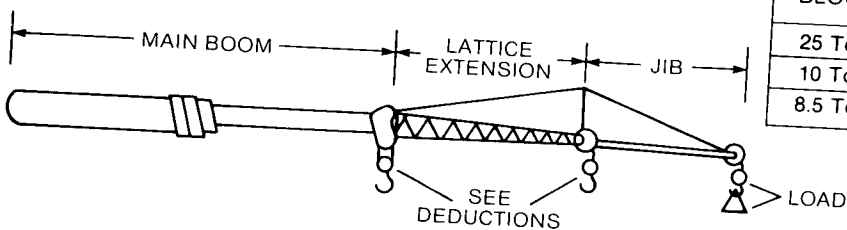
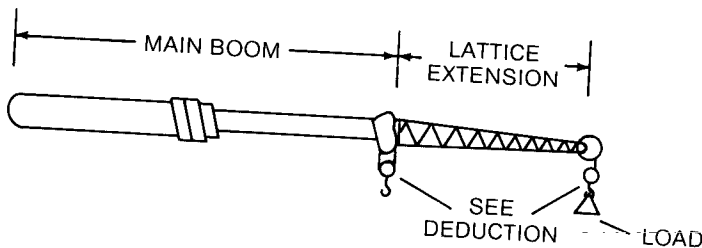
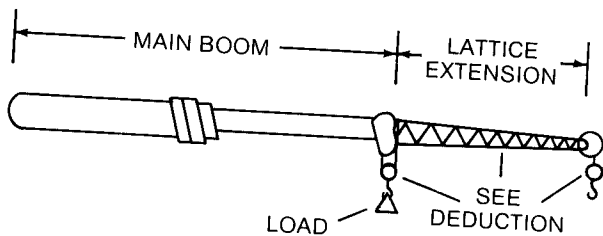
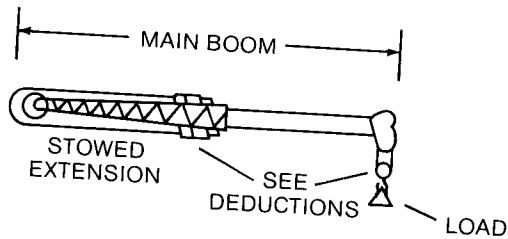

DEDUCTIONS TO BE MADE FROM MAIN BOOM RATED LOADS (IN POUNDS)			
LATTICE EXTENSION		STOWED	ERECTED
		550	1250
JIB		575	3300
HOOK BLOCK	ON BOOM POINT	ON LATTICE EXTENSION	ON JIB
25 Ton 3 Sheave	425	—	—
10 Ton 1 Sheave	342	1875	—
8.5 Ton Ball Hook	220	1650	4225
DEDUCTIONS TO BE MADE FROM LATTICE EXTENSION RATED LOADS (IN POUNDS)			
JIB		STOWED	ERECTED
		575	1250
HOOK BLOCK	ON BOOM POINT	ON LATTICE EXTENSION	ON JIB
25 Ton	325	425	—
10 Ton	250	342	—
8.5 Ton	175	220	1400
DEDUCTIONS TO BE MADE FROM JIB RATED LOADS (IN POUNDS)			
HOOK BLOCK	ON BOOM POINT	ON LATTICE EXTENSION	ON JIB
25 Ton	275	375	—
10 Ton	225	300	—
8.5 Ton	150	200	220

VEHICLE WEIGHTS: Include standard engine, standard boom (forward in travel position), standard main winch and cable, standard tires, 50 gals. (189 L.) fuel, 124 gals. (469 L.) hydraulic oil, oil cooler, fenders and counterweight.



PERFORMANCE: Six (6) forward speeds. 6 reverse speeds. Performance based on engine at full load rpm. 53,000 lb. (24,041 kg) gross vehicle weight, 16:00 x 25 tires and good surface road.

Maximum grade is under ideal conditions and limited by tire slip.

	Low Range Speeds	High Range Speeds
1st	2.3 mph (3.7 Kmph)	5.5 mph (8.8 Kmph)
2nd	4.4 mph (7.08 Kmph)	10.4 mph (16.7 Kmph)
3rd	12.5 mph (20.1 Kmph)	27.0 mph (43.4 Kmph)

CAPACITIES OF RESERVOIRS AND SYSTEMS:

	Quarts	Liters
Engine w/Filter (GM4-53T) (Deutz BF6L-913)	13 19.5	12.3 18.5
Cooling System — GM Engine & Radiator	32	30.3
Transmission	24	22.7
Axle Differential — Front	21	19.9
Rear	21	19.9
Planetary Hubs (each)	6	5.7
Hydraulic Tank	496	469
Fuel Tank	200	189.3
Swing Transmission	4	3.8
Winches (Planetaries)		
Main	2.8	2.7
Auxiliary	2.5	2.4
Swing Brake Master Cylinder	0.5	0.5
Service Brake Reservoirs	1.5	1.4

	G.V.W.	Front Axle	Rear Axle
	53,261 lb. (24,160 kg)	26,234 lb. (11,900 kg)	27,027 lb. (12,260 kg)
Effect on axle loads by adding these items:			
1580 Auxiliary winch with cable, cwt.	+ 98 lb. + 45 lb.	-30 lb. (-14 kg)	+ 128 lb. (59 kg)
1080 Auxiliary winch with cable, cwt.	+ 113 lb. (52 kg)	-10 lb. (-4 kg)	+ 123 lb. (56 kg)
20.5 x 25-20 ply tires	+ 304 lb. (138 kg)	+ 152 lb. (69 kg)	+ 152 lb. (69 kg)
Boom extension (stored)	+ 898 lb. (407 kg)	+ 1458 lb. (661 kg)	- 560 lb. (254 kg)
Auxiliary sheave (with mounting)	+ 84 lb. (38 kg)	+ 260 lb. (118 kg)	- 176 lb. (80 kg)
8.5 ton weighted hook	+ 220 lb. (100 kg)	+ 668 lb. (303 kg)	- 448 lb. (203 kg)
10 ton hook block	+ 342 lb. (155 kg)	+ 1039 lb. (471 kg)	- 697 lb. (316 kg)
25 ton hook block	+ 425 lb. (193 kg)	+ 1291 lb. (586 kg)	- 866 lb. (393 kg)
Propane heater with tank	+ 68 lb. (31 kg)	01 lb. 0	+ 69 lb. (31 kg)
Diesel heater	+ 43 lb. (19 kg)	0	+ 43 lb. (19 kg)



NOTE: All designs, specifications and components of the equipment described above are subject to change at the manufacturer's sole discretion at any time without advance notice. Data published herein is informational in nature and shall not be construed to warrant suitability of the machine for any particular purpose as performance may vary with the conditions encountered. The only warranty applicable is our standard written warranty for this machine. Manufactured and sold in conformance with U. S. Department of Commerce Commercial Standard CS-90-58.

Harnischfeger



Milwaukee, Wisconsin 53201

Address inquiries to: