

MODEL 24

4-6 TON
CAPACITY
(3.6-5.4 Tons Metric)

INDUSTRIAL YARD CRANE



- **LOW PROFILE** . . . only 7 ft. 6 in. (2.3m) high, the Grove Model 24 is ideal for close quarter operation, in plant or outside storage yard. Tail swing is only 4 ft. 7 in. (1.4m).
- **SHORT TURNING RADIUS** . . . 13 ft. 6 in. (4.1m) less than other similarly rated machines.
- **POWER-TELESCOPING BOOM** . . . 3-section, 9 ft. to 20 ft. (2.7-6.1m), providing up to 18 ft. (5.5m) of horizontal reach and with the 10 ft. (3m) boom extension added, up to 28 ft. (8.5m) and a maximum tip height of 32 ft. 6 in. (9.9m).
- **SWING** . . . 360° continuous planetary drive.
- **PICK & CARRY CAPACITY** . . . 8,000 lbs. (3625kg) over the front.
- **CARRY DECK** . . . 45 sq. ft. (4.2m²) all-steel front and side carry deck will accommodate many hard-to-handle shapes.



**HYDRAULIC
CRANES**



SUPERSTRUCTURE SPECIFICATIONS

BOOM — 9 ft. - 20 ft. (2.7m - 6.1m) three section full power with integral holding valve. Boom telescope accomplished by back to back double-acting 3 in. (76mm) bore hydraulic cylinders. Boom telescope sections are supported on Nylatron wear pads. Side adjustable wear pads prevent metal-to-metal contact of inner boom sections and permit ease of boom side alignment. Operating speeds: 24 seconds (extend), 17 seconds (retract).

***BOOM EXTENSION** — 10 ft. (3m) swing around type of all-steel welded construction. Stows along side of boom base section when not being used. Point has single 9-7/8 in. (251mm) tread diameter metallic sheave.

BOOM NOSE — All-steel, welded construction with single 14-1/4 in. (362mm) tread diameter metallic sheave.

BOOM ELEVATION — Single 6-1/2 in. (165mm) bore double-acting hydraulic cylinder with integral holding valve provides elevation from -1° to 60° . Operating speeds: 10 seconds (up), 15 seconds (down).

SWING — Grove planetary speed reducer powered by a high torque, low rpm hydraulic orbit motor providing smooth precise 360° continuous rotation. Equipped with spring-applied, hydraulically-released, non-free, multiple-disc type swing brake for precision stopping. Externally driven, swing circle bearing bolted to superstructure and carrier. Precision machined bearing mounting surface prevents distortion of swing circle bearing. Maximum swing speed 2.8 rpm.

***LOAD MOMENT — ANTI-TWO BLOCK SYSTEM (KRUGER)** — Audio-visual warning in combination with automatic lockout of: hoist up, telescope out and boom down crane functions. Kruger LMI control console provides operator with display of boom length and load moment. A separate Grove anti-two block system can be obtained independent of the complete Kruger LMI and is available with audio-visual warning only or audio-visual warning in combination with Grove automatic lockout of hoist up, telescope out and boom down crane functions.

CHASSIS SPECIFICATIONS

FRAME — High strength steel, all-welded reinforced construction with front and rear integral lifting lugs.

CARRY DECK — Steel tread plate with 45 sq. ft. (4.2m²) of total deck area. Load area maximum loading of 12,000 lbs. (5,443kg) uniformly distributed. *Set of 6 carry deck posts are available as an option.

***ENCLOSED CAB** — Frame mounted, one-man, all-steel, fully enclosed, full-vision with tinted safety glass throughout. Hinged door with lockable handle, electric windshield wiper, dome-light, hot water heater, electric defroster fan, fully adjustable industrial type vinyl seat, roof mounted skylight.

***OVERHEAD GUARD** — Tubular construction with expanded metal top. Available only without enclosed cab.

CONTROLS — Left of steering wheel are dash-mounted hand operated control levers for swing and boom telescope; to the right are control levers for outriggers, boom elevation and main hoist. Foot operated controls include service brakes and engine throttle. To right of steering wheel on dash are outrigger sequence controls (push buttons), *heater control, transmission shift controls and ignition switch. At lower left side of seat is the hand operated emergency/parking brake controls. Steering wheel mounted electric horn button and *turn signal/4-way flasher control. All basic craning and traveling controls.

INSTRUMENTATION — Voltmeter, hourmeter, electric fuel gauge, engine oil pressure gauge, transmission temperature gauge and engine water temperature gauge.

OUTRIGGERS — Front and rear folding arm toggle linkage style with both outriggers on one end actuated by a single 5 in. bore (127mm) double-acting hydraulic cylinder with integral holding valve; 7 ft. 7-3/4 in. (2.33m) spread centerline to centerline of pad, retract to 6 ft. 2 in. (1.88m) overall width. Two hand sequence control arrangement eliminates unintentional activation.

TRANSMISSION — Funk powershift with single-stage torque converter, engine mounted, 3 speeds forward and 3 reverse, with full flow radiator bottom tank oil cooler, dash-mounted temperature gauge and remote mounted oil filter.

AXLES — Front: Single reduction drive with hypoid gears, 7.8:1 ratio; solid-mounted with floating axle shafts and no-spin differential.

Rear: Grove wide track steer type (no oscillation).

STEERING — Power assist hydraulic on rear wheels.

SERVICE BRAKES — Hydraulic drum and shoe type on all wheels. Size 12.5 in. x 2.25 in. (318mm x 57mm). Total lining area 263.2 sq. in. (1698cm²).

PARKING BRAKE — Mechanical hand lever actuated, caliper brake acting on a 9.75 in. (248mm) diameter disc on transmission output flange.

TIRES — (Four) 10:00x15-14PR tube-type, Mine and Industrial Service.

***TOW WINCH** — Grove model HO-7, front mounted inside frame, completely enclosed; 6,550 lb. (2,970kg) max. single line pull (less rope and hook). Operated by outrigger hand lever through selector valve arrangement.

HYDRAULIC SYSTEM:

RESERVOIR — 32.5 gallon (123 liter) capacity, all steel with internal baffles and cleanout access, exterior oil sight level gauge, breather cap, in-tank filter and magnetic dipstick.

FILTER — Return line replaceable cartridge with bypass protection and filter bypass indicator. 10 micron rating. In-tank mounted.

PUMPS — Single section, gear-type, pto driven off transmission countershaft to permit continuous pump operation with transmission in neutral; combined capacity of 29 GPM (110 LPM) @ 2400 RPM @ 2,000 PSI (141 kg/cm²). Separate vane steering pump — 10 GPM (38 LPM) @ 2400 RPM @ 100 PSI (7kg/cm²).

CONTROL VALVES — Four-way double-acting hydraulic valves with integral main by-pass for system relief and individual circuit by-pass relief. Single valve bank with a mid-inlet section splitting the bank into two individual valve groups, permitting simultaneous, independent control of two crane functions. Maximum operating pressure 2500 PSI (175.8kg/cm²) for crane functions.

POWER DISTRIBUTION — Rotary gear flow divider separates main pump flow into a 70/30 split (70% available flow to hoist, lift and outrigger functions; 30% available flow to swing and telescope functions).

MISCELLANEOUS STANDARD EQUIPMENT — 2-3/4 lb. (1.3kg) dry type fire extinguisher, console light, lockable fuel cap, hourmeter, full engine hood.

***MISCELLANEOUS OPTIONAL EQUIPMENT** — Electronic back-up alarm, pintle hooks, 360° amber beacon, LP gas, complete light package, hoist drum cable follower.

*Denotes optional equipment

MAIN HOIST DATA

DESCRIPTION: Power up and down, equal speed, planetary reduction with integral automatic brake.		
Drum Dimensions	11-1/2 in. (292mm) diameter 4-3/16 in. (160mm) length 16 in. (406mm) flange diameter	
Performance:	MAX. SINGLE LINE SPEED (FULL LOAD)	STATIC SINGLE LINE PULL
Bare Drum	87 FPM (27m/mm)	8200 lb. (3720kg)
Mean Drum	101 FPM (31m/mm)	7650 lb. (3470kg)
Full Drum	111 FPM (34m/mm)	6740 lb. (3057kg)
Drum Wire Rope Capacity	104 ft. (31.7m) of 1/2 in. (13mm) diameter (4th layer)	
Permissible Single Line Rope Pull with 3.5:1 Safety Factor	1/2 in. (13mm) diameter 6x37 class - EIPS, IWRC 7,460 lb. (3,384kg)	

NOTE: All performance data on basis of using 1/2 in. (13mm) diameter wire rope.

ENGINE SPECIFICATIONS

MAKE & MODEL	Perkins 4.203	*Perkins 4.203
TYPE	4 cylinder gasoline	4 cylinder diesel
BORE	3.6 in. (91mm)	3.6 in. (91mm)
STROKE	5.0 in. (127mm)	5.0 in. (127mm)
DISPLACEMENT	203.6 cu. in. (3337cm ³)	203.6 cu. in. (337cm ³)
HORSEPOWER (NET)	61 @ 2250	58 @2250
GOVERNED RPM	2250	2250
TORQUE (NET)	172 ft. lb. (23.8kg.m) @1250	154 ft. lb. (21.3kg.m) @1300
ELECTRICAL SYSTEM	12 volt, negative ground	12 volt, negative ground
STARTING SYSTEM	12 volt	12 volt
COMBUSTION SYSTEM	4 cycle, naturally aspirated	4 cycle, naturally aspirated
COOLING SYSTEM	Liquid	Liquid
FUEL CAPACITY	20 gal. (76 liters)	20 gal. (76 liters)
ALTERNATOR	42 AMP	42 AMP
BATTERY	+(2) 475 total CCA @ 0°F	+(2) 475 total CCA @ 0°F
AIR CLEANER	Dry type	Dry type
HOURLY METER	Standard	Standard

*Denotes optional equipment

+CCA = Cold cranking amperage

SPEED AND GRADEABILITY

Power Plant	Ratio	Gear Range (Fwd. or Rev.)	Max. Speed		Gradeability @ Stall (%)	Drawbar Pull @ Stall	
			MPH	KM/H		LGS.	KGS.
Perkins 4.203 Gas	5.90	1	4.5		92.0	7,609	3,451
	2.29	2	11.5		24.9	2,794	1,267
	1.08	3	24.3		9.6	1,180	535
*Perkins 4.203 Diesel	5.90	1	4.5		79.0	6,979	3,165
	2.29	2	11.5		22.5	2,250	1,165
	1.08	3	24.3		8.5	1,065	483

NOTE: All performance data is based on a 13,000 lb. (5,897kg) GVW machine with 10:00x15 tires, Funk powershift transmission and a 7.8:1 axle ratio operating on concrete surface. Performance data may vary plus or minus 10% due to variations in engine performance and vehicle weights. Drawbar pull values above 3,055 lbs. (1,385kg) and gradeability values above 23.5% are theoretical and are limited by the torque required to slip the tires (based on an unladen machine with a GVW of 13,000 lbs. [5,897kg]).

Constant improvement and engineering progress make it necessary that we reserve the right to make specification, equipment and price changes without notice.

DIMENSIONAL CHARTS

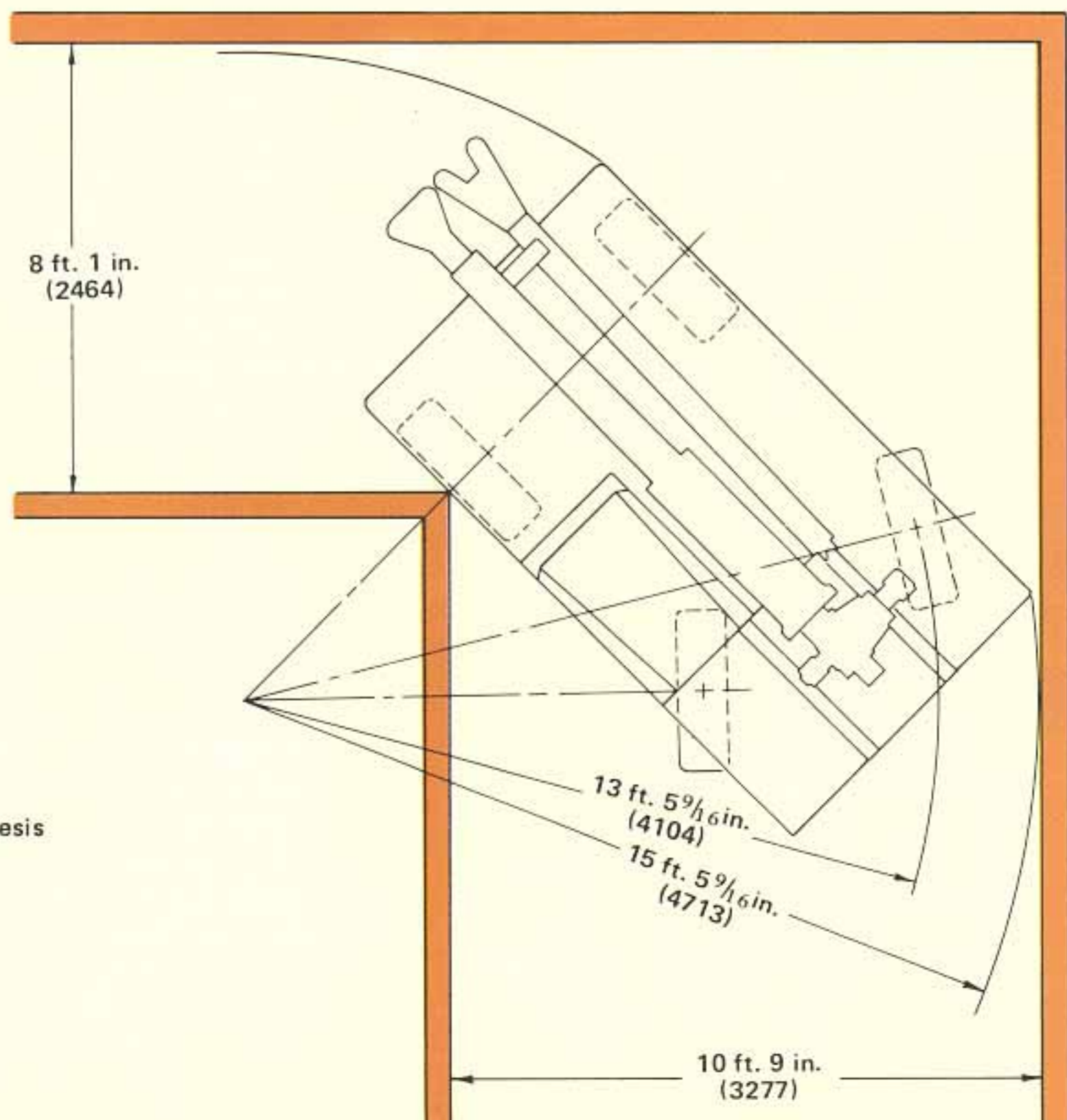
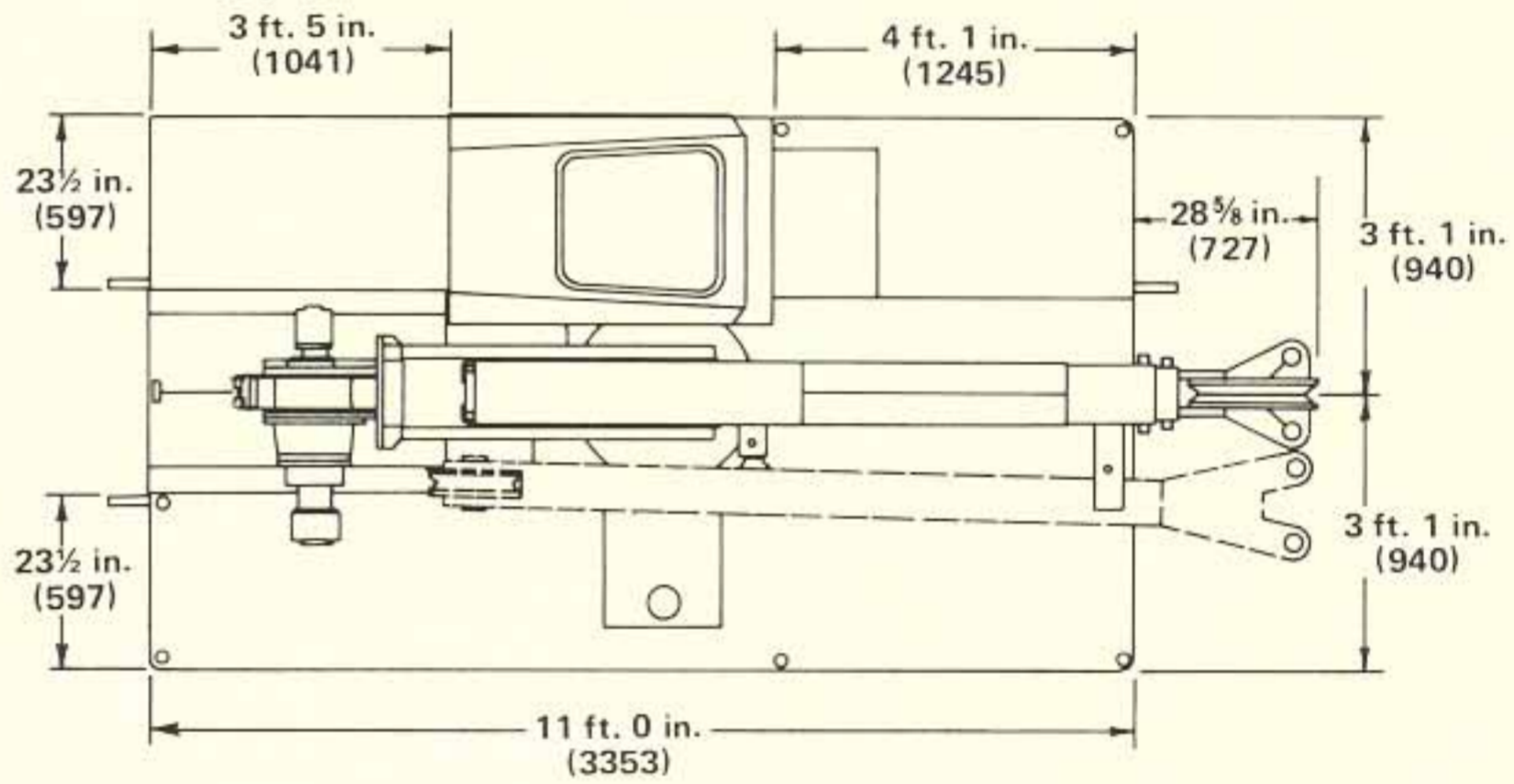
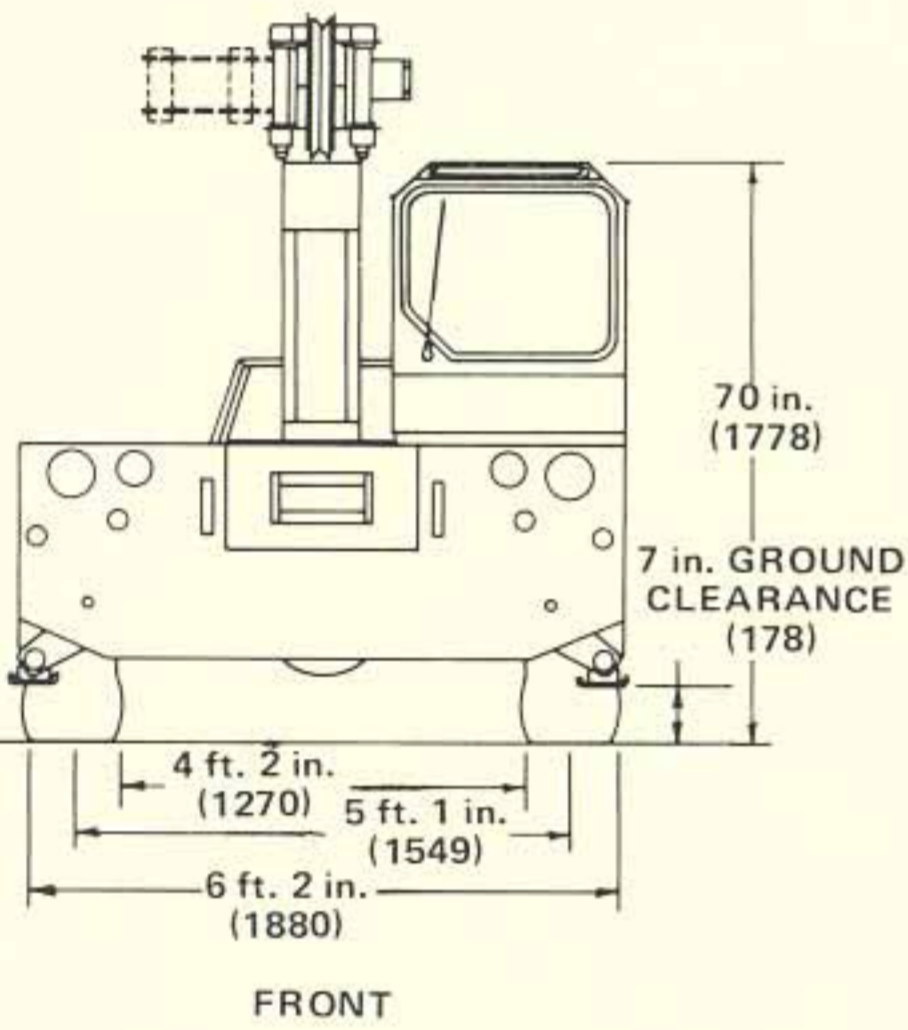
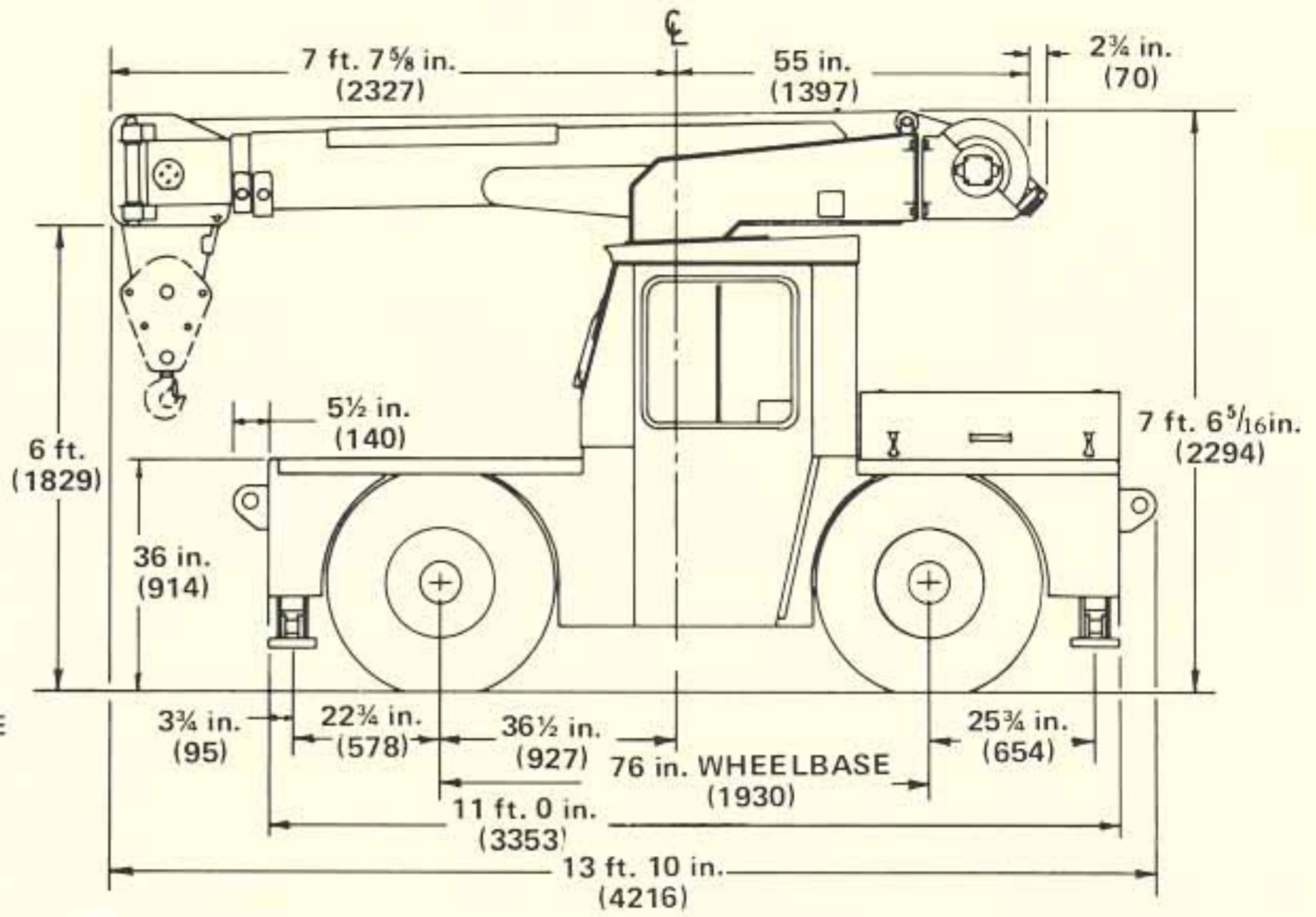
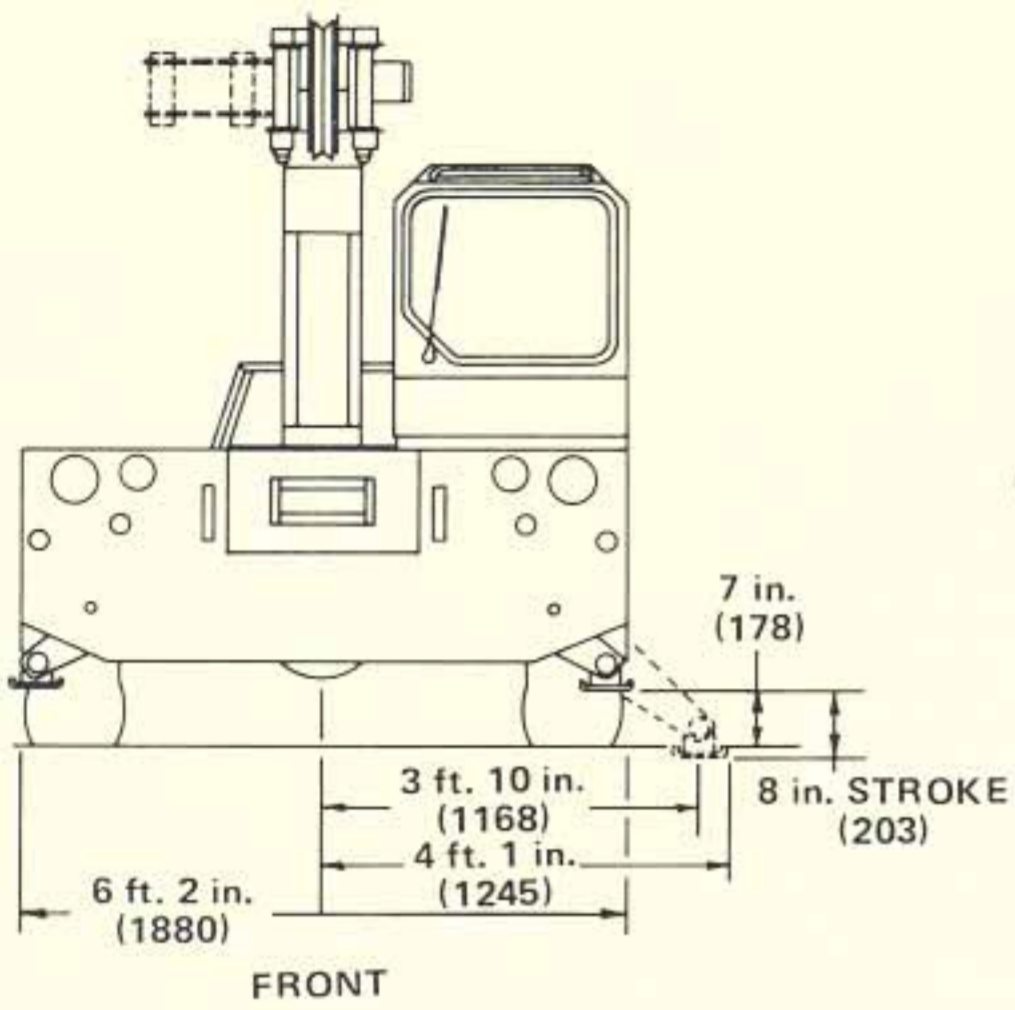

NOTE: Dimensions shown in parenthesis are millimeters (mm)



MODEL 24

WEIGHT CHART

ITEM	LBS.	KGS.
+Basic standard unit	12,155	5,514
ADD:		
Enclosed cab	190	86
10 ft. (3m) boom ext.	334	152
Tow winch	575	261
Hookblock	119	54
Headache ball	42	19
SUBSTITUTE:		
Perkins 4.203 diesel	0	0
Chassis weight of basic standard unit	9,095	4,126
Superstructure weight of basic standard unit	3,060	1,388

+Basic standard unit consists of: 9 ft. to 20 ft. (2.7m - 6.1m) boom, Perkins gas engine, HO-7 hoist with 75 ft. (22.8m) of ½ in. (13mm) rope, front and rear outriggers, open cab, full fuel tank and hydraulic reservoir.



3-section power-telescoping boom plus boom extension provides a tip height of 32 ft. 6 in. (9.9m) and a horizontal reach of 27.6 ft. (8.4m). Notice the excellent visibility provided by the large windows and skylight. Carry-deck area is 45 sq. ft. (42m²).



The arrangement of controls is consistent in all Grove cranes. Notice the neat, business-like appearance and convenience of crane function controls to driving controls.



Serviceability is always an important consideration. On the Model 24, the engine position provides ready access to routine service needs.

THE WORLD'S MOST COMPLETE LINE OF HYDRAULIC INDUSTRIAL CRANES

Capacities
from
2 through
35 tons
(1.8-31.8 metric tons)



INDUSTRIAL CRANES

GROVE MANUFACTURING COMPANY

1000E
Box 21 SHADY GROVE, PENNA. 17256

Your Grove Distributor