

National Crane Series T300A

Product Guide



Features

- 27,2 t (30 USt) rating
- 33,52 m (110 ft) four-section boom
- Self-lubricating Easy Glide wear pads
- Internal anti-two-block
- Vision cab



Features



Four-section boom

At 33,52 m (110 ft), the Series 1300A four-section boom is the longest in its size range. The long boom allows the operator to perform more lifts without the use of a jib, reducing setup time and improving efficiency. A 21 m (69 ft) four-section boom or a 30,5m (100 ft) four-section boom is also available.

National Crane Series 1300A

- 27,2 t (30 USt) maximum capacity
- 49,68 m (163 ft) with optional jib maximum vertical reach
- 36,27 m (119 ft) maximum vertical hydraulic reach



Operator's cab

The Series 1300A's Vision cab has a rigid powder coated steel structure and is well insulated with ample safety glass for operator visibility and comfort. A multi-position seat with arm rest and single axis joystick controls, ventilation fans, diesel heater, wipers are also included. Air conditioning is available as an option.



Outriggers

Two sets of "HO" style outriggers with 6,09 m (20 ft) span and 4,27 m (14 ft) mid span setting. Outriggers are equipped with removable ball and socket aluminum foot pads. Independent outrigger controls (umbilical design) are located at the rear of the crane and includes sight bubble level indicator.

Easy Glide boom wear pads

Easy Glide boom wear pads reduce the conditions that cause boom chatter resulting in smoother crane operation.



Best in class performance and serviceability

- The stronger standard torsion box improves rigidity, reduces truck frame flex and reduces the need for counterweight
- Speedy-reeve boom tip and sheave blocks simplify rigging changes by decreasing the time needed to change line reeving
- Crane components painted before assembly reduce the chance of rust, improve serviceability and enhance the appearance of the crane
- Internal anti-two block wiring standard on the 1300A routes the wiring through the inside of the boom eliminating the possibility of snagging the wire on obstructions
- Bearings on the boom extend and retract cables can be greased through access holes in the boom side plates and a number of internal boom parts has been reduced improving serviceability
- The Series 1300A is supplied with 360° continuous rotation standard along with the “glide swing” feature allowing free swing during rotation and a manually applied foot brake
- Adjustable swing speed comes standard on the 1300A. A control knob located on the swing motor brake release valve can be easily adjusted to the crane operator’s swing speed preference
- Oil cooler-radiator mounted on top of front outriggers with electric fan is standard



Contents

Features	2
Mounting configurations	5
Specifications	6
Capacities	8
Dimensions	11
Accessories	12

Mounting configuration

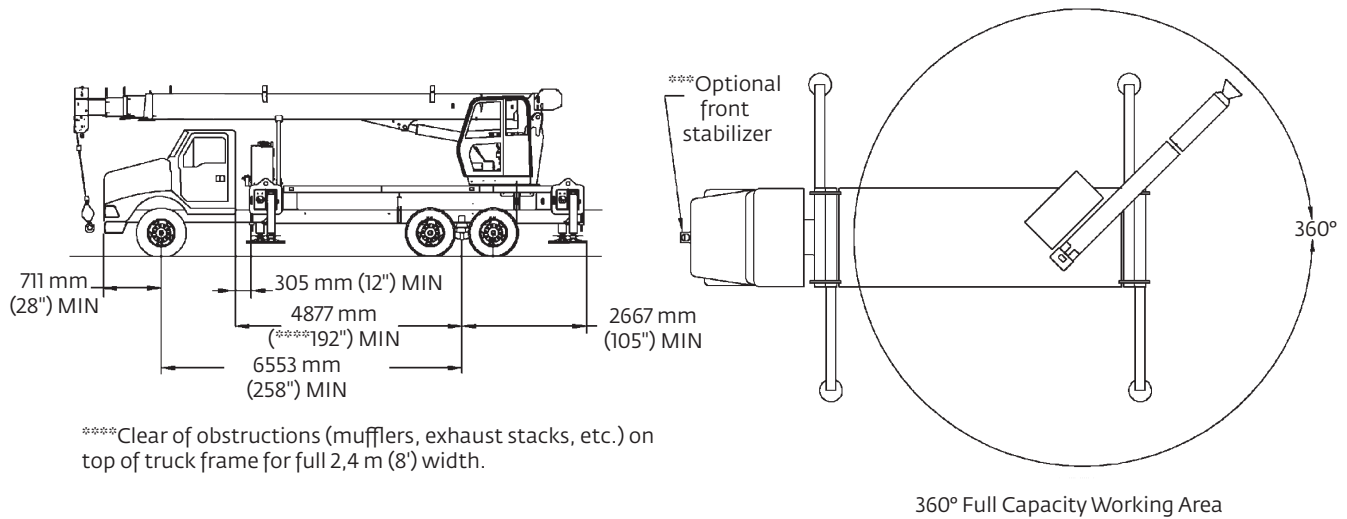

****Clear of obstructions (mufflers, exhaust stacks, etc.) on top of truck frame for full 2,4 m (8') width.

The mounting configuration shown is based on an 85% stability factor. The complete unit must be installed on the truck in accordance with factory requirements, and a test performed to determine actual stability and counterweight requirements, since individual truck chassis vary. If bare truck weights are not met, counterweight will be required. A summary of mounting and truck requirements are:

Working area:
360°

Gross axle weight rating (GAWR):
front 8165 kg (18,000 lb)

Gross axle weight rating (GAWR):
rear 15 455 kg (34,000 lb)

Gross vehicle weight rating:
23 587 kg (52,000 lb)

Wheelbase (WB):
6,55 m (258 in)

Cab to axle/trunnion (CT):
4877 mm (192 in)

After frame (AF):
2667 mm (105 in) minimum

Frame section modulus (SM), front axle to end of afterframe:
759 MPa (110,000 psi) 327 cm³ (20 in³) See "Truck Frame Strength" section.

Estimated bare chassis weight required for stability prior to installation of crane or accessories:
Front 4082 kg (9000 lb)
Rear 3856 kg (8500 lb)*
4536 kg (10,000 lb) with optional bed

Front axle maximum weight**:
4763 kg (10,500 lb)

4536 kg (*10,000 lb) is required at the rear axle for 360° stability. This weight does include the weight of the optional bed. Counterweight will be required above the 3856 kg (8500 lb) minimum bare chassis if the optional bed is not used to attain the 4536 kg (10,000 lb) stability weight.

**Weight in excess of 4763 kg (10,500 lb) will require the addition of a front stabilizer or additional rear axle stability weight for over front stability. One-half of the front axle weight in excess of the maximum at the rear axle will maintain stability.

Example: A 4990 kg (11,000 lb) Bare Front Axle will maintain stability if the rear axle bare is 3969 kg (8750 lb) and 4649 kg (10,250 lb) with the additional optional bed weight.

***A single front stabilizer is not necessary for 360° stability if mounting dimensions are maintained and minimum rear axle and maximum front axle weights are not exceeded.

NOTE 1: Gross Vehicle Weight Rating (GVWR) is dependent on all components of the vehicle (axles, tires, springs, frame, etc.) meeting manufacturers' recommendations; always specify GVWR when purchasing trucks.

NOTE 2: Diesel engines require a variable speed governor for smooth crane operation; electronic fuel injection is required.

NOTE 3: All mounting data is based on a National Crane Series 1300A with subbase and an 85% stability factor.

NOTE 4: The complete unit must be installed in accordance with factory requirements, and a test performed to determine actual stability and counterweight requirements; contact the factory for details.

NOTE 5: Transmission neutral safety interlock switch is required.

Specifications

Boom and jib combinations data

Available in three basic models.

Model 1369A — Equipped with a 6,7 m - 21,03 m (22 ft - 69 ft) four-section boom. Maximum tip height is 23,77 m (78 ft).
6,7 m - 21,03 m (22 ft - 69 ft) four-section boom.



Model 13100A — Equipped with a 8,83 m - 30,48 m (29 ft - 100 ft) four-section boom. This model can be equipped with a 7,62 - 13,41 m (25 ft - 44 ft) two section jib. Maximum tip height with 13,41 m (44 ft) jib is 44,63 m (153 ft).

8,83 m - 30,48 m (29 ft - 100 ft) four-section boom. **13FJ44M** 7,62 m - 13,41 m (25 ft - 44 ft) two-section jib



Model 13110A — Equipped with a 10,05 m - 33,52 m (33 ft - 110 ft) four-section boom. This model can be equipped with a 7,62 - 13,41 m (25 ft - 44 ft) two-section jib. Maximum tip height with 13,41 m (44 ft) jib is 49,68 m (163 ft).

10,05 m - 33,52 m (32 ft - 110 ft) four-section boom. **13FJ44M** 7,62 m - 13,41 m (25 ft - 44 ft) two-section jib









Note: Maximum tip height is measured with outriggers/stabilizers fully extended.

Specifications

1300A winch data

- Do not deadhead line block against boom tip when extending boom
- Keep at least three wraps of loadline on drum at all times.
- Use only 9/16 in diameter rotation-resistant cable with 38,400 lb breaking strength on this machine.
- MAXIMUM BOOM LENGTH AT MAXIMUM ELEVATION WITH RIGGING SHOWN WITH LOAD BLOCK AT GROUND LEVEL

1 part line	2 part line	3 part line	4 part line	5 part line	6 part line	7 part line
						
100 ft boom/jib	100 ft	85 ft	58 ft	44 ft	29 ft	29 ft
110 ft boom/jib	110 ft	78 ft	62 ft	46 ft	32 ft	32 ft

Winch	Cable supplied	Average breaking strength	Lift and speed	Lift and speed	Lift and speed	Lift and speed	Lift and speed	Lift and speed	Lift and speed
Standard planetary winch	9/16" diameter rotation resistant	17 464 kg (38,500 lb)	3493 kg (7700 lb) 50 m/min (164 fpm)	6986 kg (15,400 lb) 25 m/min (82 fpm)	10 478 kg (23,100 lb) 16 m/min (55 fpm)	13 971 kg (30,800 lb) 12 m/min (41 fpm)	17 464 kg (38,500 lb) 10 m/min (33 fpm)	20 956 kg (46,200 lb) 8 m/min (27 fpm)	24 449 kg (53,900 lb) 7 m/min (23 fpm)
*Burst of speed winch	9/16" diameter rotation resistant	17 464 kg (38,500 lb)	1361 kg (3000 lb) 111 m/min (265 fpm)	2722 kg (6000 lb) 40 m/min (132 fpm)	4083 kg (9000 lb) 27 m/min (88 fpm)	5443 kg (12,000 lb) 20 m/min (66 fpm)	6804 kg (15,000 lb) 16 m/min (53 fpm)	8165 kg (18,000 lb) 13 m/min (44 fpm)	9526 kg (21,000 lb) 11 m/min (38 fpm)

All winch pulls and speeds in this chart are shown on the fourth layer. Winch line pulls would increase on the first, second and third layers. Winch line speed would decrease on the first, second and third layers. Winch line pulls may be limited by the winch capacity or the ANSI 5 to 1 cable safety factor. These are shown below.

Winch	4th layer drum pull	Allowable cable pull
Standard planetary	3493 kg (7700 lb) low speed 1361 kg (3000 lb) "Burst of Speed"	3492 kg (7700 lb)

Loadline deduct		
Block type	Rating	Weight
Downhaul weight	4,53 t (5 USt)	68 kg (150 lb)
1-sheave block	10,89 t (12 USt)	139 kg (305 lb)
2-sheave block	17,24 t (19 USt)	159 kg (350 lb)
3-sheave block	27,22 t (30 USt)	261 kg (575 lb)

Capacities

1369A: 69 ft boom, full-span outriggers

Other Series 1300A Load Rating Charts are available. National Crane will send you a chart on request – or you may secure needed load rating information through your nearest National Crane dealer.

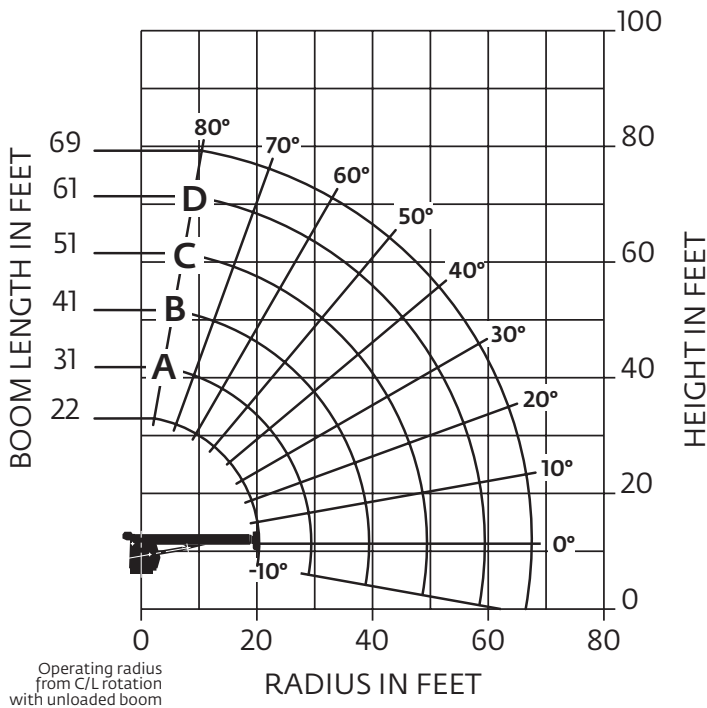

CAUTION:

- Do not operate crane booms, jib extensions, any accessories or loads within 3 m (10 ft) of live power lines or other conductors of electricity.
- Jib and boom capacities shown are maximum for each section.
- Do not exceed capacities at reduced radii.
- Load ratings shown on the appropriate charts are maximum allowable loads with the crane mounted on a factory-approved truck and all outriggers at either full span or at mid span range and set on a firm level surface so that the crane is level and all tires are suspended.
- Always level the crane with the level indicator located on the crane.
- The operator must reduce load to allow for factors such as wind, ground conditions, operating speeds and their effects on freely suspended loads.
- Overloading this crane may cause structural collapse or instability.
- Weights on any accessories attached to the boom or loadline must be deducted from the load chart capacities.
- Do not exceed jib capabilities at any reduced boom lengths.
- Do not deadhead lineblock against boom tip when extending boom or winching up.
- Keep at least three wraps of loadline on drum at all times.
- Use only specified cable with this machine.

Load chart

22 ft – 69 ft (6.7 – 21.03 M) BOOM RATED LOADS WITHOUT JIB

LOADED RADIUS (ft)	LOADED BOOM ANGLE (deg)	22 ft BOOM (lb)	LOADED BOOM ANGLE (deg)	A 31 ft BOOM (lb)	LOADED BOOM ANGLE (deg)	B 41 ft BOOM (lb)	LOADED BOOM ANGLE (deg)	C 51 ft BOOM (lb)	LOADED BOOM ANGLE (deg)	D 61 ft BOOM (lb)	LOADED BOOM ANGLE (deg)	69 ft BOOM (lb)
5	74.5	*60,000										
8	66	47,500	74	33,500	78.5	33,400						
10	59.5	40,300	70	33,100	75.5	32,300	79.5	35,000				
12	52.5	34,900	66	32,700	72.5	31,100	77	30,100	80	29,000		
15	41.5	28,600	59.5	27,300	68	25,900	73.5	24,900	77	24,200	79	19,350
20			47	21,200	60	20,300	67	19,500	72	18,850	74.5	18,450
25			32	16,550	51	16,600	60.5	16,000	66.5	15,450	70	15,050
30					41	13,800	53.5	13,500	61	13,050	65.5	12,700
35					27.5	10,900	46	11,050	55.5	11,150	60.5	10,950
40							37	8750	49	8850	55.5	8950
45							26	7200	42.5	7300	50	7350
50									34.5	6050	44	6100
55									24	5100	37	5150
60											29	4350
65											17.5	3700
	0	13,300	0	8500	0	5700	0	4050	0	2950	0	2300

*Shaded areas are structurally limited capacities.

THIS CHART IS ONLY A GUIDE AND SHOULD NOT BE USED TO OPERATE THE CRANE.

The individual crane's load chart, operating instructions and other instructional plates must be read and understood prior to operating the crane.

Capacities

13100A: 100 ft boom, with 25 ft - 44 ft jib, full span outriggers

Other Series 1300A Load Rating Charts are available. National Crane will send you a chart on request – or you may secure needed load rating information through your nearest National Crane dealer.

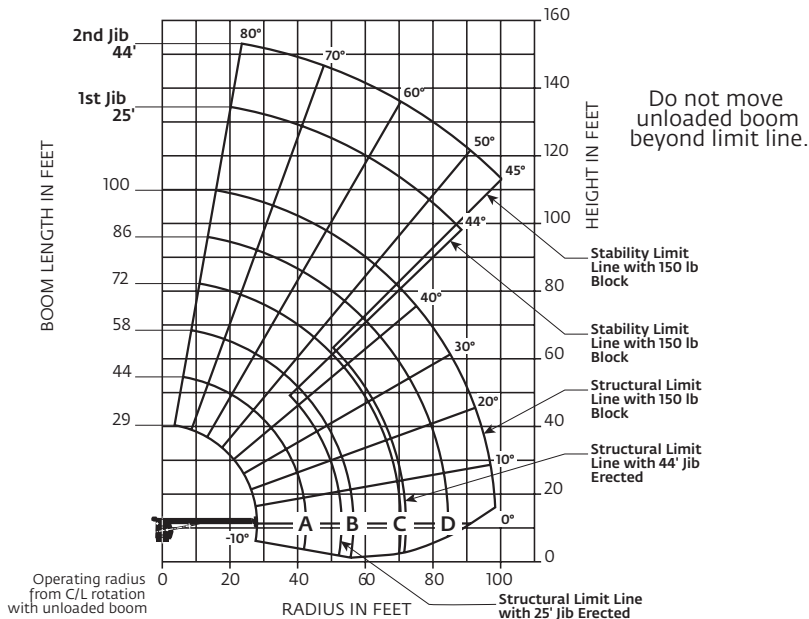

CAUTION:

- Do not operate crane booms, jib extensions, any accessories or loads within 3 m (10 ft) of live power lines or other conductors of electricity.
- Jib and boom capacities shown are maximum for each section.
- Do not exceed capacities at reduced radii.
- Load ratings shown on the appropriate charts are maximum allowable loads with the crane mounted on a factory-approved truck and all outriggers at either full span or at mid span range and set on a firm level surface so that the crane is level and all tires are suspended.
- Always level the crane with the level indicator located on the crane.
- The operator must reduce load to allow for factors such as wind, ground conditions, operating speeds and their effects on freely suspended loads.
- Overloading this crane may cause structural collapse or instability.
- Weights on any accessories attached to the boom or loadline must be deducted from the load chart capacities.
- Do not exceed jib capabilities at any reduced boom lengths.
- Do not deadhead lineblock against boom tip when extending boom or winching up.
- Keep at least three wraps of loadline on drum at all times.
- Use only specified cable with this machine.

BOOM LENGTH (ft)	25 - 44 ft JIB STOWED
29	Reduce load 800 lb
44	Reduce load 600 lb
58	Reduce load 450 lb
72	Reduce load 350 lb
86	Reduce load 300 lb
100	Reduce load 250 lb

RATED LOAD REDUCTIONS WITH STOWED JIB

Note:

1. All capacities are in pounds, angles in degrees, and radii in feet.
2. Loaded boom angles are given as reference only.
3. Shaded areas are structurally limited capacities.
4. Handling of personnel is only permitted with full span extension of all outrigger and stabilizer beams.
- *5. See owners manuals. The 60,000 lb load requires optional 9/16" diameter 6x25 IWRC cable.

NOTE:

1. Operate with jib by radius when main boom is fully extended. If necessary increase boom angle to maintain loaded radius.
2. Operate with jib by boom angle when main boom is not fully extended. Do not exceed rated jib capacities at any reduced boom lengths.

Load chart

29 ft - 100 ft (8,83 m - 30,48 m) BOOM RATED LOADS WITHOUT JIB

LOADED RADIUS (ft)	LOADED BOOM ANGLE (deg)	29 ft BOOM (lb)	LOADED BOOM ANGLE (deg)	A 44 ft BOOM (lb)	LOADED BOOM ANGLE (deg)	B 58 ft BOOM (lb)	LOADED BOOM ANGLE (deg)	C 72 ft BOOM (lb)	LOADED BOOM ANGLE (deg)	D 86 ft BOOM (lb)	LOADED BOOM ANGLE (deg)	100 ft BOOM (lb)
5	79.5	*60,000										
8	73	44,000	79	29,100								
10	68.5	36,900	76.5	29,000								
12	65	31,900	74	28,600	78.5	28,600						
15	57	26,400	69.5	24,600	75.5	23,500	79.5	22,900				
20	46	20,100	62.5	19,000	70.5	18,050	75.5	17,450	78.5	16,300	80	10,650
25	29	14,800	55	15,350	65	14,600	71	14,050	75.5	13,700	77.5	10,450
30			46.5	12,300	59	12,150	66.5	11,700	71.5	11,350	75	10,000
35			36	9700	53	10,000	62	9900	68	9600	72	9400
40			22	7700	46	8050	57.5	8300	64	8250	69	8050
45					38.5	6500	52.5	6700	60	6900	66	7000
50					29	5200	47	5450	56	5600	62	5750
55					15	4200	40.5	4400	52	4600	59	4700
60							33.5	3600	47.5	3800	55.5	3900
65							24.5	2950	42	3100	51.5	3250
70							10	2100	36.5	2550	47.5	2700
75									29.5	2100	43	2200
80									21	1650	38.5	1800
85											33	1450
90											26.5	1100
95											17.5	750
100												
	0	7900	0	4100	0	2250	0	1100				

25 TO 44 ft JIB RATED LOADS				
LOADED RADIUS (ft)	LOADED BOOM ANGLE (deg)	25 ft JIB (lb)	LOADED BOOM ANGLE (deg)	44 ft JIB (lb)
30	78	5100		
35	76	5100	78	2800
40	75	4950	76	2650
45	71	4450	74	2600
50	69	4150	72	2500
55	67	3850	70.5	2500
60	64	3550	68.5	2350
65	62	3200	66.5	2250
70	59	2500	64.5	2150
75	56	2100	62	2050
80	52.5	1650	59.5	1950
85	49.5	1250	57.5	1650
90	45	900	55	1400
95	42	550	52.5	1100
100			48.5	850
105			45.5	600
110				

*Shaded areas are structurally limited capacities.

THIS CHART IS ONLY A GUIDE AND SHOULD NOT BE USED TO OPERATE THE CRANE.

Capacities

13110A: 110 ft boom, with 25 ft - 44 ft jib, full span outriggers

Other Series 1300A Load Rating Charts are available. National Crane will send you a chart on request – or you may secure needed load rating information through your nearest National Crane dealer.

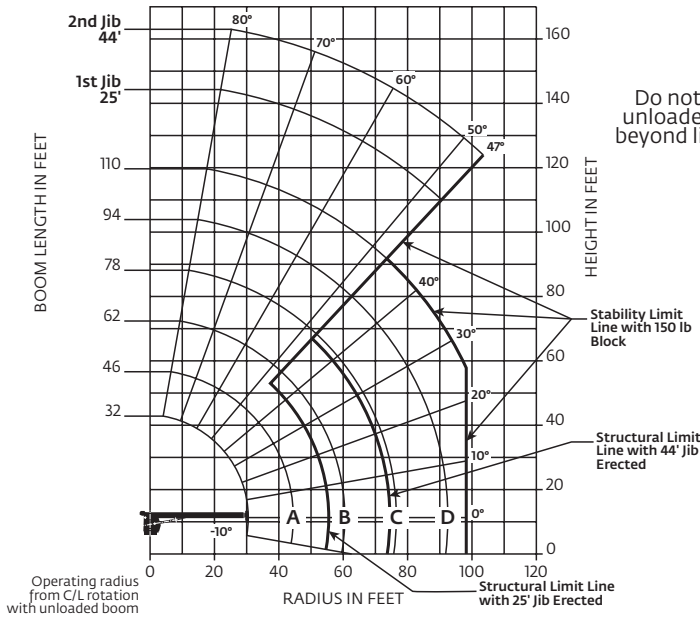

CAUTION:

- Do not operate crane booms, jib extensions, any accessories or loads within 3 m (10 ft) of live power lines or other conductors of electricity.
- Jib and boom capacities shown are maximum for each section.
- Do not exceed capacities at reduced radii.
- Load ratings shown on the appropriate charts are maximum allowable loads with the crane mounted on a factory-approved truck and all outriggers at either full span or at mid span range and set on a firm level surface so that the crane is level and all tires are suspended.
- Always level the crane with the level indicator located on the crane.
- The operator must reduce load to allow for factors such as wind, ground conditions, operating speeds and their effects on freely suspended loads.
- Overloading this crane may cause structural collapse or instability.
- Weights on any accessories attached to the boom or loadline must be deducted from the load chart capacities.
- Do not exceed jib capabilities at any reduced boom lengths.
- Do not deadhead lineblock against boom tip when extending boom or winching up.
- Keep at least three wraps of loadline on drum at all times.
- Use only specified cable with this machine.

NOTE:

1. Operate with jib by radius when main boom is fully extended. If necessary increase boom angle to maintain loaded radius.
2. Operate with jib by boom angle when main boom is not fully extended. Do not exceed rated jib capacities at any reduced boom lengths.

BOOM LENGTH (ft)	25 - 44 ft JIB STOWED
32	Reduce load 800 lb
46	Reduce load 600 lb
62	Reduce load 450 lb
78	Reduce load 350 lb
94	Reduce load 300 lb
110	Reduce load 250 lb

Note:

1. All capacities are in pounds, angles in degrees, and radii in feet.
2. Loaded boom angles are given as reference only.
3. Shaded areas are structurally limited capacities.
4. Handling of personnel is only permitted with full span extension of all outrigger and stabilizer beams.
5. See owners manuals. The 60,000 lb load requires optional 9/16" diameter 6x25 IWRC cable.

Load chart

32 ft - 110 ft BOOM RATED LOADS WITHOUT JIB

LOADED RADIUS (ft)	LOADED BOOM ANGLE (deg)	32 ft BOOM (ft)	LOADED BOOM ANGLE (deg)	A 46 ft BOOM (ft)	LOADED BOOM ANGLE (deg)	B 62 ft BOOM (ft)	LOADED BOOM ANGLE (deg)	C 78 ft BOOM (ft)	LOADED BOOM ANGLE (deg)	D 94 ft BOOM (ft)	LOADED BOOM ANGLE (deg)	110 ft BOOM (ft)
5	78.5	*60,000										
8	74.5	43,000										
10	70.5	35,900	77.5	29,100								
12	66.5	30,900	75	28,900								
15	60	25,500	71	24,000	77	23,000						
20	48.5	19,450	63.5	18,450	72	17,550	77	17,000				
25	34	14,900	56	14,800	67	14,100	73	13,600	77.5	13,300		
30			48	12,150	61.5	11,650	69	11,200	74	10,950	77	7950
35			38.5	9600	56	9850	64.5	9450	70.5	9200	71.5	6300
40			27	7600	49.5	7950	60.5	8100	67	7850	74	5950
45					43.5	6350	56	6600	64	6800	69	5700
50					36	5100	51.5	5350	60	5550	66	5400
55					26	4050	46	4300	56	4550	63	4750
60					8.5	2650	40	3500	52	3700	59.5	3900
65							33.5	2850	48	3000	56	3200
70							25.5	2250	43	2450	52.5	2600
75							13	1750	38	1950	49	2100
80									32	1500	45	1650
85									25	1100	41	1250
90									15	750	36	900
95											31	600
100												
0		6300	0	3250	0	1450	0					

25 - 44 ft JIB RATED LOADS				
LOADED RADIUS (ft)	LOADED BOOM ANGLE (deg)	25 ft JIB (ft)	LOADED BOOM ANGLE (deg)	44 ft JIB (ft)
35	76.5	4200		
40	75	4100	76.5	2500
45	73	4000	75.5	2500
50	71	3850	74	2500
55	69	3600	72.5	2500
60	66.5	3300	70.5	2350
65	64	3050	68.5	2250
70	61.5	2500	66.5	2150
75	59	2000	64.5	2050
80	56	1550	62	1900
85	53.5	1100	60	1800
90	50.5	700	57	1400
95			54.5	1050
100			51.5	650
105				

*Shaded areas are structurally limited capacities.

THIS CHART IS ONLY A GUIDE AND SHOULD NOT BE USED TO OPERATE THE CRANE.

The individual crane's load chart, operating instructions and other instructional plates must be read and understood prior to operating the crane.

Dimensions

G Center of gravity from centerline		
Series	G	With oil weight
1369A	88.2 ft**	11,184 kg ** (24,657 lb)
13100A	108.6 ft	12,806 kg (28,233 lb)
13110A	113.9 ft	13,141 kg (28,971 lb)

*Weight includes all items including complete HO outriggers, 68 kg (150 lb) downhaul weight, reservoir, wood decks, oil cooler, ladders, jib and cab, booms fully retracted.

**Jib is not included in 69 ft boom weight and CG.

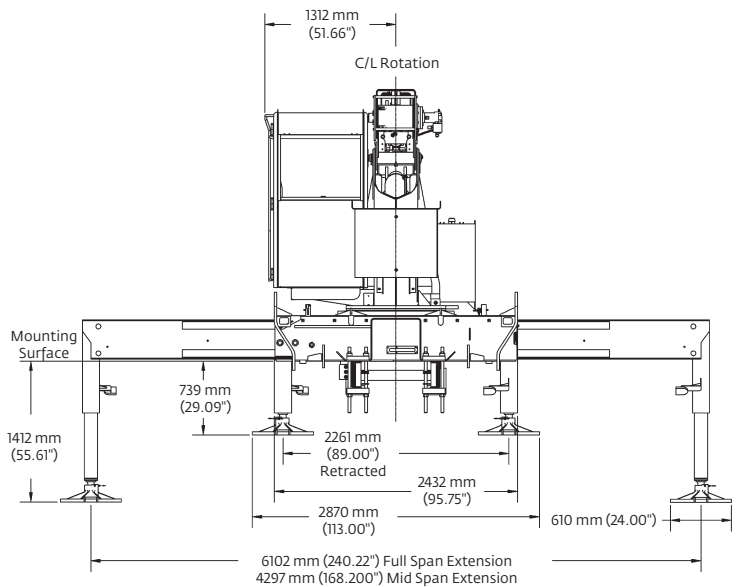
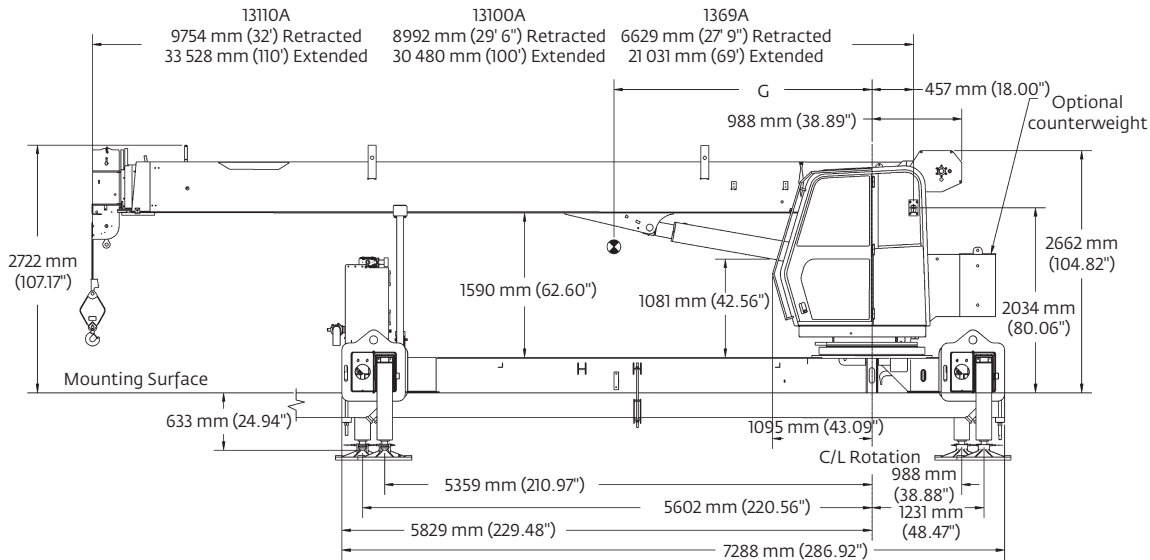
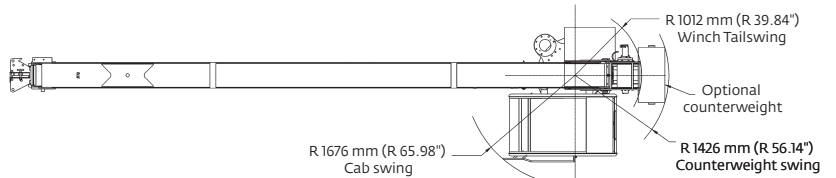

Dimensions are in mm (in) unless otherwise specified.

Accessories

Radio Remote Controls –

Eliminate the handling and maintenance concerns that accompany cabled remotes. Operate to a range of about 250 ft (76 m), varying with conditions.

- NB4R

Heavy-duty Personnel Basket –

1,200 lb (544 kg) capacity steel basket with safety loops for two passengers. Gravity leveling 72 x 42 in (183 x 107 cm) platform. Fast attachment and secure locking systems. Load chart must show 2,300 lb (1043 kg) minimum to operate this accessory.

- BSA-1
- BSA-R1 (provides rotation)
- BSAY-1
- BSAY-2

Air Conditioning –

Back of cab mounted, self contained modular unit with in cab cool air outlets. Requires 130+ amp. chassis alternator.

- AC

Outrigger Controls at operator's seat in addition to ground controls.

- ICORC

Single Front Outrigger –

Center mount front stabilizer with a 25 in vertical stroke with first-up feature.

- SFO

Open Seat Controls –

Open seat controls with railing in lieu of cab.

- SSC

Spanish-Language Danger Decals, Control Knobs, and Operators' Manuals

- SDD
- SOM

Notes

Manitowoc Cranes

Regional headquarters

Americas

Manitowoc, Wisconsin, USA

Tel: +1 920 684 6621

Fax: +1 920 683 6277

Shady Grove, Pennsylvania, USA

Tel: +1 717 597 8121

Fax: +1 717 597 4062

Europe, Middle East, Africa

Ecully, France

Tel: +33 (0)4 72 18 20 20

Fax: +33 (0)4 72 18 20 00

China

Shanghai, China

Tel: +86 21 6457 0066

Fax: +86 21 6457 4955

Greater Asia-Pacific

Singapore

Tel: +65 6264 1188

Fax: +65 6862 4040

Regional offices

Americas

Brazil

Alphaville

Mexico

Monterrey

Chile

Santiago

Europe, Middle East,

Africa

Czech Republic

Netvorice

France

Baudemont

Cergy

Decines

Germany

Langenfeld

Hungary

Budapest

Italy

Lainate

Netherlands

Breda

Poland

Warsaw

Portugal

Baltar

Russia

Moscow

U.A.E.

Dubai

U.K.

Buckingham

China

Beijing

Chengdu

Guangzhou

Xian

Greater Asia-Pacific

Australia

Adelaide

Brisbane

Melbourne

Sydney

India

Calcutta

Chennai

Delhi

Hyderabad

Pune

Korea

Seoul

Philippines

Makati City

Singapore

Factories

Brazil

Alphaville

China

TaiAn

Zhangjiagang

France

Charlieu

Moulins

Germany

Wilhelmshaven

India

Pune

Italy

Niella Tanaro

Portugal

Baltar

Fânzeres

Slovakia

Saris

USA

Manitowoc

Port Washington

Shady Grove

This document is non-contractual. Constant improvement and engineering progress make it necessary that we reserve the right to make specification, equipment, and price changes without notice. Illustrations shown may include optional equipment and accessories and may not include all standard equipment.