

LORAIN® LRT 275D

rough terrain crane
27.5 ton (25.0 mt) capacity
specifications

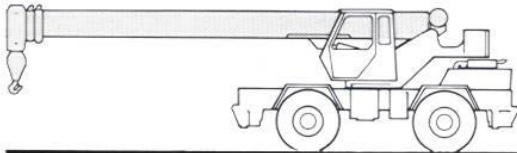

STANDARD BOOM EQUIPMENT

BOOM

30-72 ft. (9.23-22.19 m), three section, full power, self-proportioning boom. Single lever control. Adjustable rollers for top and intermediate sections provide for easier telescoping, less maintenance and less wear. Single boom hoist cylinder. All cylinders equipped with integral hold valves. Boom elevation is -5° to 76° . Pendulum boom angle indicator mounted on boom

BOOM HEAD

Four metallic sheaves and two idler sheaves mounted on heavy duty, anti-friction bearings. Quick reeving boom head eliminates need to remove wedge and socket from rope.

OPTIONAL BOOM EQUIPMENT

MAIN BOOM

30-94 ft. (9.23-28.78 m) four section boom, three sections full power, self-proportioning to 72' (22.19 m). Fourth section is power pinned pull out section. Single lever control of full power telescoping sections. Adjustable rollers for top and intermediate sections provide for easier telescoping, less maintenance and less wear. Single boom hoist cylinder. All cylinders equipped with integral hold valves. Boom elevation -5° to 76° . Pendulum boom angle indicator mounted on boom.

JIBS

15-20 ft. (4.57-6.10 m) extendible A-frame jib with single metallic sheave mounted on anti-friction bearing. Jib is stowed beneath the boom base section. The 15 ft. (4.57 m) jib is extendible to 20 ft. (6.10 m) by means of a 5 ft. (1.52 m) pull-out tip section. Can be offset 24° . Installs to main boom only.

26 ft. (7.92 m) offsetting side stow swing-on one-piece lattice type jib offsets 0° , 15° and 30° . Single metallic sheave mounted on anti-friction bearing. Installs to main boom only.

26-43 ft. (7.92-13.10 m) offsetting side stow swing-on lattice type jib offsets 0° , 15° and 30° . Single sheave mounted on anti-friction bearing. Jib is extendible to 43 ft. (13.10 m) by means of a 17 ft. (5.18 m) manual pull-out tip section, roller supported for ease of extension. Installs to main boom only.

AUXILIARY BOOM HEAD

Removable auxiliary boom head has single metallic sheave mounted on an anti-friction bearing. Removable pin-type rope guard for quick reeving.

HOOK BLOCK

30 ton (27.2 mt) capacity, four metallic sheaves and hook latch. Quick reeving design.

HOOK & BALL

6.25 ton (5.7 mt) top swivel ball with hook and hook latch.

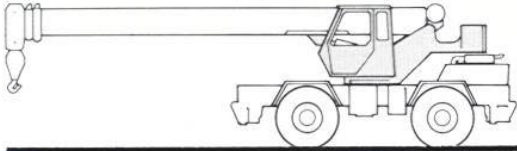

STANDARD UPPERSTRUCTURE EQUIPMENT

UPPERSTRUCTURE FRAME

All welded one-piece structure fabricated with high tensile strength alloy steel. Counterweight is bolted to frame.

TURNTABLE CONNECTION

Swing bearing is single row, ball-type, with external teeth. The swing gear is bolted to revolving upperstructure and welded to carrier frame.

SWING

A hydraulic motor drives a double planetary reduction gear for precise and smooth swing function. Swing speed (no load) is 3.0 rpm.

SWING BRAKE

Heavy duty, multiple disc swing brake is mechanically actuated from operator's cab by foot pedal. Brake may be operated to hold upperstructure at any desired degree of rotation. Brake is released by hand.

ANTI-TWO BLOCK SYSTEM

Anti-two block system with audio/visual warning and automatic function disconnects.

OPERATOR'S CAB

Environmental cab, all steel construction, mounted on vibration absorbing pads, optimum visibility, safety glass throughout and rubber floor matting. The cab has a sliding door on the left side, sliding windows on the right side, hinged tinted Lexan® skylight and removable front windshield. Acoustical foam padding insulates against sound and weather. The deluxe six-way adjustable operator's seat includes head and arm rests.

CONTROLS

All control levers and pedals are positioned for efficient operation. Hand-operated control levers include swing,

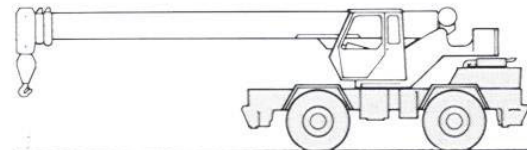

boom telescope, boom hoist, single lever two-speed main winch, transmission shift, transmission forward-neutral-reverse and hand throttle. Foot control pedals include boom raise, boom lower, brake, accelerator and swing brake.

INSTRUMENTATION AND ACCESSORIES

In cab gauges include air pressure, bubble level, engine oil pressure, fuel, engine temperature, voltmeter, transmission temperature, and transmission oil pressure. Switches include ignition, engine stop, transmission high-low range, steering mode, outrigger controls. Indicators include low air, high water temperature/low oil pressure audio/visual warning, high transmission temperature and two-block visual and audio monitors. Accessories include fire extinguisher; light package including headlights, tail lights, brake lights, directional signals and four-way hazard flashers; windshield washer/wiper; L.H. rear view mirror; dash light, and seat belt.

HYDRAULIC CONTROL VALVES

Valves are mounted on the upperstructure and are easily accessible. Valves include one four-spool main valve for boom hoist, telescope, main winch, and main winch boost and one single spool valve for swing. Quick disconnects are provided for quick connection of pressure check gauges.

OPTIONAL EQUIPMENT

Auxiliary Winch • Winch Cable Rollers • Drum Rotation Indicators • 360° House Lock • Swing Gear Cover • Heater/Defroster • Air Conditioner • Tinted Safety Glass • Vandal and Scratch Resistant Glass • Tinted Vandal and Scratch Resistant Glass • Torsion Bar Suspension for Bucket Seat • Roof Window Electric Wiper • Tachometer • Work Lights • Load Moment Indicators • Load on Hook Indicator • Dome Light.

STANDARD CARRIER EQUIPMENT

CARRIER CHASSIS

Chassis is Lorain designed and built with four-wheel drive and four-wheel steer (4x4x4). Has box type construction with reinforcing cross members, a welded precision machined turntable mounting plate and integrally welded outrigger boxes. Decking has anti-skid surfaces, including tool storage compartment.

AXLES AND SUSPENSION

Rear axle is a planetary drive/steer type with automatic oscillation lockouts. The oscillation lockouts automatically engage when the superstructure is swung 10 degrees in either direction.

Front axle is a planetary drive/steer type rigid mounted to the frame for increased stability.

TIRES

Std: 16:00 x 25-24 P.R. lug type tubeless tires with fenders

Opt: 20.5 x 25-24 P.R. lug type tubeless tires with fenders

BRAKES

Front/rear brake size is 17.00 x 4.00 in. (432 x 102 mm) on each wheel. Total brake area: 605.2 in² (3904 cm²). The combination parking brake and emergency brake is a spring-applied, air released disc operating brake on the transmission output shaft. Parking brake automatically engages when ignition is switched off or switch in cab is manually actuated.

STANDARD CARRIER EQUIPMENT (continued)

STEERING

Hydraulic four-wheel power steering for two-wheel, four-wheel, or crab steer is easily controlled by steering wheel.

Turning radius 2-wheel 31 ft. 6 in. (9.60 m)
(Standard tires) 4-wheel 18 ft. 5 in. (5.61 m)

TRANSMISSION

Full power-shift transmission with integral torque converter has neutral safety start, 6 speeds forward, and 6 speeds reverse. Two position range shift. Automatic pulsating backup alarm.

OUTRIGGERS

POWRSPAN® out and down fully independent hydraulic outriggers extending 18 ft. (5.49 m) centerline to centerline include easily removable steel floats each with an area of 254 in² (1639 cm²) which are stowable on the carrier frame. Complete controls and sight leveling bubble are located in operator's cab.

HYDRAULIC SYSTEM

HYDRAULIC PUMPS

Three gear type pumps, one single and two in tandem, driven off the transmission. Combined system capability is 115 gpm (435 lpm). Includes pump disconnect.

Main and Auxiliary Winch Pump

54 gpm (204.4 lpm) @ 3200 psi (225.3 kg/cm²).

Boom Hoist, Telescope and Winch Boost Pump

40 gpm (151.4 lpm) @ 3500 psi (246 kg/cm²).

Power Steering, Outrigger and Swing Pump

21 gpm (79.5 lpm) @ 2500 psi (175 kg/cm²).

FILTRATION

Full flow oil filtration system with bypass protection includes a removable 100 mesh (140 micron) suction screen-type filter and a 5 micron replaceable return line filter.

HYDRAULIC RESERVOIR

All steel, welded construction with internal baffles and diffuser. Provides easy access to filters and is equipped with an external sight level gauge. The hydraulic tank is pressurized to aid in keeping out contaminants and in reducing potential pump cavitation. Capacity is 81 gallons (307 l).

OPTIONAL EQUIPMENT

No Spin Plantetary Drive/Steer Rear Axle • Cold Weather Starting Aid • Immersion Heater • Hydraulic Oil Cooler • Auxiliary Steering System • Pintle Hooks • Back-up Lights • Air Dryer • Fuel Water Separator.

MAIN WINCH SPECIFICATIONS

Lorain built hydraulic winch with planetary reduction gearing provides two-speed operation with equal speeds for power up and down. Winch is equipped with an integral automatic brake.

PERFORMANCE	LO-RANGE	HI-RANGE
Max. line speed (no load)		
First layer	240 fpm (73 m/min)	412 fpm (125 m/min)
Fifth layer	327 fpm (100 m/min)	562 fpm (171 m/min)
Max. line pull — First layer	10,100 lbs (4582 kg)	
Permissible line pull	7,600 lbs (3447 kg)	

DRUM DIMENSIONS	DRUM CAPACITY
10.5 in (267 mm) drum diameter	Max. Storage: 815 ft. (248 m)
16.1 in (409 mm) length	6th & 7th layers not working layers
16.6 in (422 mm) flange dia.	Max Useable: 540 ft (165 m)*
Cable ½ in x 500 ft (12.7 mm x 137.2 m)	
Cable type 6 x 19 IWRC-XIPS regular lay preformed	*Based on minimum flange height above top layer to comply with ANSI B30.5.

OPTIONAL AUXILIARY WINCH

Lorain hydraulic winch, power up and down, equal speed, planetary reduction with integral automatic brake.

PERFORMANCE	
Max. line speed (no load)	
Third layer	280 fpm (85 m/min)
Max. line pull	
First layer	10,100 lbs (4582 kg)

DRUM DIMENSIONS
10.5 in (267 mm) drum diameter
16.1 in (409 mm) length
16.6 in (422 mm) flange diameter
Cable: ½ in. x 300 ft. (12.7 mm x 91.4 m)
Cable type: 6 x 19 IWRC-XIPS regular lay preformed

DRUM CAPACITY
Max. storage: 815 ft (248 m)

PERFORMANCE (Standard Engine)

Transmission Range	Gear	Forward Drive	Maximum Speed	Maximum Tractive Effort	Gradeability @ Stall
Low	1	4-wheel	2.3 mph 3.7 km/h	37,856 lbs 17,171 kg	112.34%
	2	4-wheel	4.4 mph 7.1 km/h	19,254 lbs 8,734 kg	39.84%
	3	4-wheel	12.4 mph 20.0 km/h	6,431 lbs 2,917 kg	11.10%
High	1	2-wheel	5.0 mph 8.0 km/h	16,893 lbs 7,663 kg	34.04%
	2	2-wheel	9.5 mph 15.3 km/h	8,589 lbs 3,896 kg	15.59%
	3	2-wheel	24.5 mph 39.4 km/h	2,849 lbs 1,292 kg	3.77%

ENGINE SPECIFICATIONS

	Standard	Optional
Make & Model	Cummins 6BT5.9	Detroit Diesel 8.2L
Type	6 cylinder	8 cylinder
Bore & Stroke	4.02 x 4.72 in (102 x 120 mm)	4.25 x 4.41 in (108 x 112 mm)
Displacement	359 cu in (5.9 l)	500 cu in (8.2 l)
Max. Gross Horsepower	130 hp (97 kw) @ 2500 rpm	125 hp (93 kw) @ 2500 rpm
Max. Gross Torque	368 lbs•ft./1200 rpm (51 kg•m/1200 rpm)	318 lbs•ft./1000 rpm (44 kg•m/1000 rpm)
Net Horsepower	117 hp (87 kw) @ 2500 rpm	112 hp (84 kw) @ 2500 rpm
Aspiration	turbocharged	naturally aspirated
Air Filter	dry type	dry type
Electric System	12 volt	12 volt
Alternator	102 amp	65 amp
Battery	(2) 12 V-1250 C.C.A.	(2) 12 V-1250 C.C.A.
Fuel Capacity	50 gal (189 l)	50 gal (189 l)

All performance data is based on a gross vehicle weight of 52,000 lbs (23,583 kg), 16.00 x 25 tires, 4 x 4 drive. Performance may vary due to engine performance. Gradeability data is theoretical and is limited by tire slip, stability, or engine oil pan design.

GENERAL DIMENSIONS

NOTES:

- Dimensions given assume the boom is fully retracted in travel position and 16:00 x 25 tires.
- Minimum ground clearance under transmission and axles: 18" (0.46 m).
- Track width:
6'7.50" (2.02 m) 16:00 x 25 tires
6'10.5" (2.10 m) 20.5 x 25 tires

- Width of carrier:
8'0" (2.44 m) 16:00 x 25 tires
8'8" (2.64 m) 20.5 x 25 tires

Tire to frame angle

16.00 and 20.5 tires

Approach angle: 24°
Departure angle: 25°

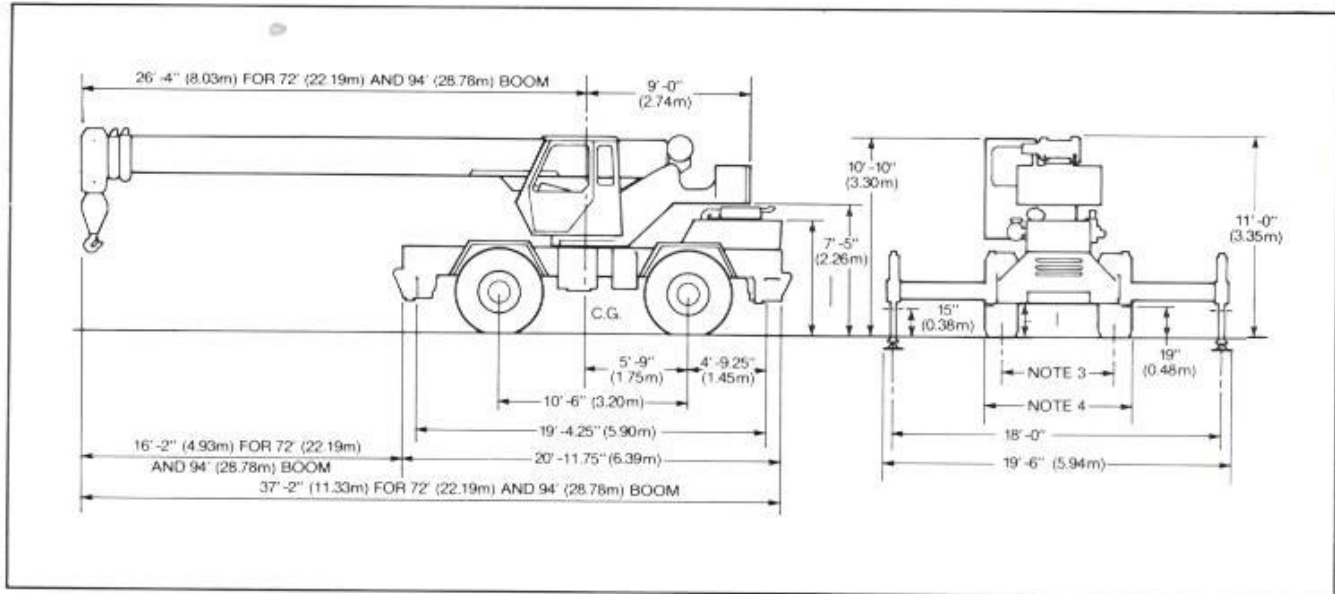

WEIGHTS & AXLE LOADS	GROSS WEIGHT LBS.	UPPER FACING FRONT		GROSS WEIGHT KG.	UPPER FACING FRONT	
		FRONT	REAR		FRONT	REAR
Basic Crane with 7200 lb. (3266 kg) Counterweight	48,895	27,100	21,795	22,174	12,290	9884
Add Options:						
15'-20' (4.57-6.10 m) Jib (Stowed)	+ 610	+1,330	- 720	+ 277	+ 603	- 326
26' (7.92 m) Swing-on Jib Stowed	+ 850	+1,450	- 600	+ 386	+ 658	- 272
26'-43' (7.92-13.10 m) Swing-on Jib (Stowed)	+1,150	+1,950	- 800	+ 522	+ 885	- 363
Auxiliary Boom Head	+ 100	+ 315	- 215	+ 45	+ 143	- 98
30 ton (27.2 mt) Hook Block	+ 427	+ 740	- 313	+ 194	+ 336	- 142
Hook and Ball (In Tool box)	+ 121	+ 145	- 24	+ 55	+ 65	- 10
Auxiliary Winch with Wire Rope	0	0	0	0	0	0
Hydraulic Oil Cooler	+ 150	- 60	+ 210	+ 68	- 27	+ 95
Pintle Hook						
Front	+ 45	+ 70	- 25	+ 20	+ 32	- 12
Rear	+ 45	- 25	+ 70	+ 20	- 12	+ 32
Substitute:						
94' (28.78 m) Boom	+1,105	+1,710	- 605	+ 501	+ 776	- 275
Detroit Diesel 8.2L	+ 250	—	+ 250	+ 113	—	+ 113
20.5 x 25 tires	+ 460	+ 230	+ 230	+ 140	+ 70	+ 70

NOTE: Weights are for Lorain supplied equipment and subject to 2% variation due to manufacturing tolerances.

WE RESERVE THE RIGHT TO AMEND THESE SPECIFICATIONS AT ANY TIME WITHOUT NOTICE. THE ONLY WARRANTY APPLICABLE IS OUR STANDARD WRITTEN WARRANTY APPLICABLE TO THE PARTICULAR PRODUCT AND SALE. WE MAKE NO OTHER WARRANTY, EXPRESSED OR IMPLIED.



Koehring Cranes & Excavators
Waverly, Iowa 50677