

QY160

Crawler Crane Technical Manual

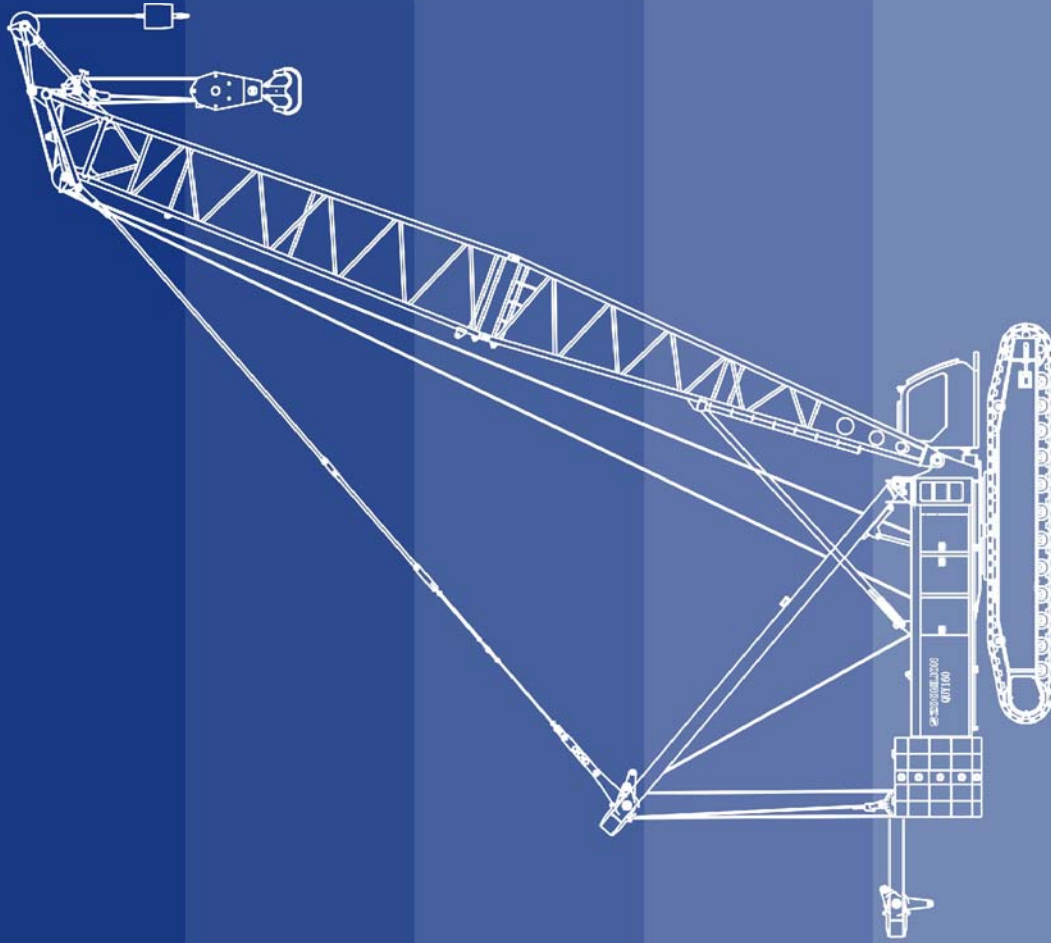

Add: No. 613, 3rd section of Middle Fu Rong Rd Changsha City, Hunan Province, China
Tel: +86-731-5667238
Fax: +86-731-5682997
E-mail: hotline-crane@zoomlion.com
PC: 410007

2009 © Copyright by Zoomlion Heavy Industry Science & Technology. We reserve the right to make improvements and changes to our products without notice. If there are any differences between technical parameters given in the manual and product delivered for you, please refer to the product.

www.zoomlion.com

I. Overall dimensions and main parameters

| | |
|--|----|
| 1) Overall dimensions of basic machine | 01 |
| 2) Main technical parameters | 02 |
| 3) Transport dimensions and weights of main components | 03 |

II. Technical instruction

| | |
|-----------------------|----|
| 4) Boom system | 05 |
| 5) Working mechanism | 06 |
| 6) Crane system | 07 |
| 7) Safety equipment | 07 |
| 8) Operator's cab | 08 |
| 9) Load hook | 08 |

III. Self-assembly & dismantling function 09

IV. Lifting capacity

| | |
|-------------------------------------|----|
| 10) Lifting performance on S boom | 11 |
| 11) Lifting performance on SF boom | 14 |
| 12) Lifting performance on SW boom | 24 |

I . Overall dimensions and main parameters

1.Overall dimensions of basic machine

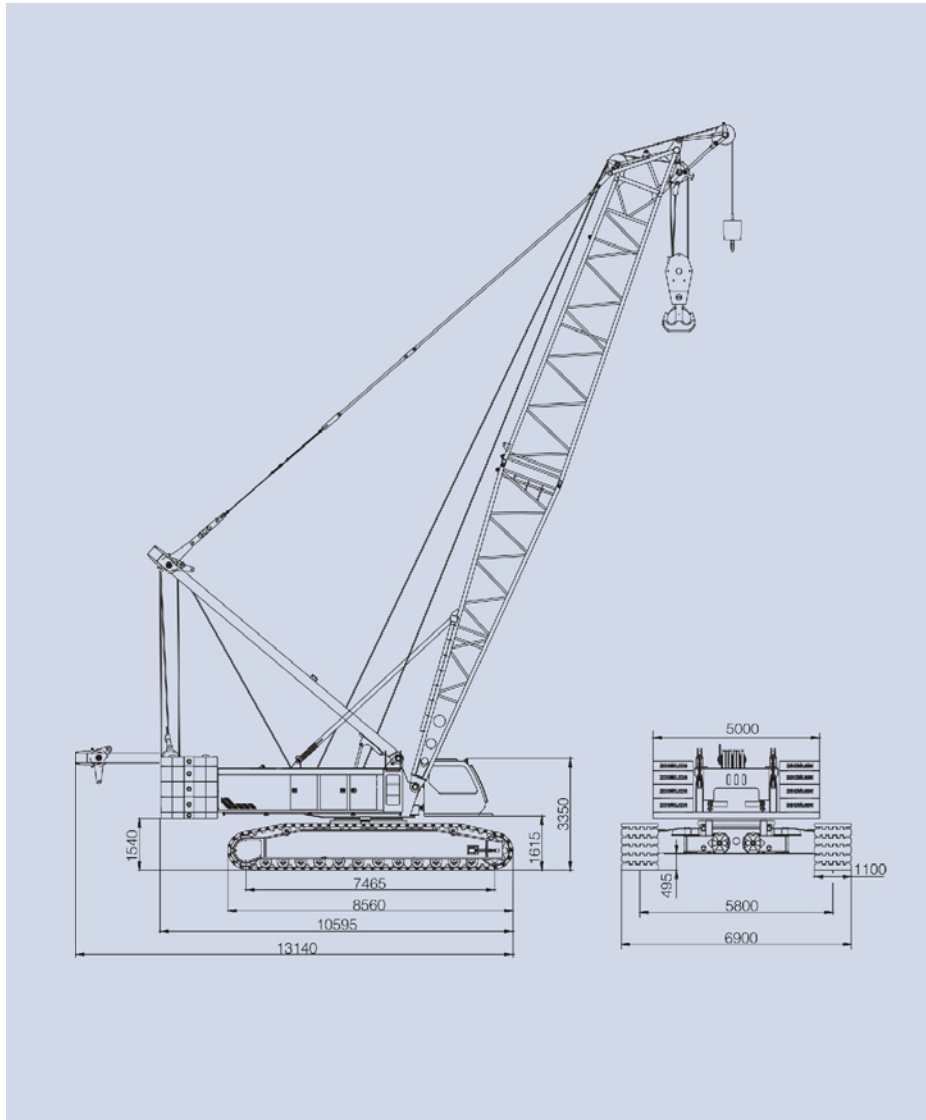

2.Main technical parameters

| Item | Unit | Value | Remarks | |
|--|-------------------------------------|--------------------|----------------------------------|--------------------------------|
| Max. lifting capacity × radius | t × m | 160 × 5 | | |
| Deadweight with basic boom | t | 167 | | |
| Main boom length | m | 20~83 | | |
| Fixed jib length | m | 13~31 | | |
| Max. lifting capacity on fixed jib | t | 22 | | |
| Fixed jib angle | ° | 10,30 | | |
| Max. length of main boom with fixed jib | m | 71 + 31 | Main boom length: 47~71 | |
| Luffing jib length | m | 24~51 | | |
| Max. lifting capacity on luffing jib | t | 38 | | |
| Main boom angle when luffing jib is used | ° | 85, 75, 65 | | |
| Max. length of main boom with luffing jib | m | 56 + 51 | Main boom length: 38~56 | |
| Single rope speed of winches | Hoisting winch 1 | m/min | 110 | The 6 th rope layer |
| | Hoisting winch 2 | m/min | 110 | The 6 th rope layer |
| | Derricking winch | m/min | 30 | The 5 th rope layer |
| Slewing speed | rpm | 1.4 | | |
| Traveling speed | km/h | 1.2 | | |
| Gradeability | % | 30% | | |
| Ground pressure | MPa | 0.1 | | |
| Overall dimensions (L × W × H) | m | 10.6 × 6.9 × 3.34 | Without A-frame and boom frame | |
| Engine | Rated power/rotational speed | kW/rpm | 227/2000 | |
| | Max. output torque/rotational speed | Nm/rpm | 1505/1400 | |
| | Exhaust emission standard | | U.S. EPA Tier 3 and EU Stage III | |
| Distance between track center × crawler contact length × crawler width | mm | 5800 × 7465 × 1100 | | |

3. Transport dimensions and weights of main components

Unit: mm

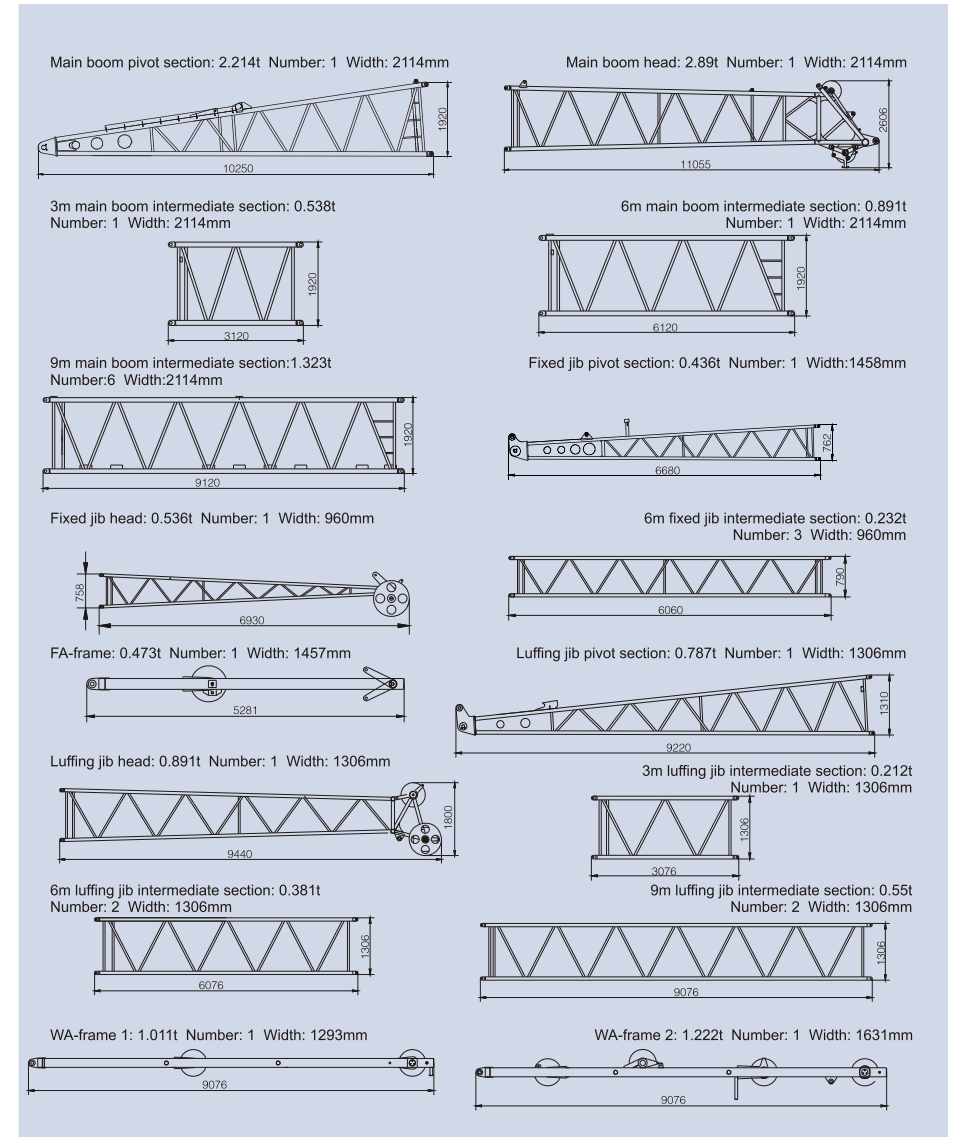
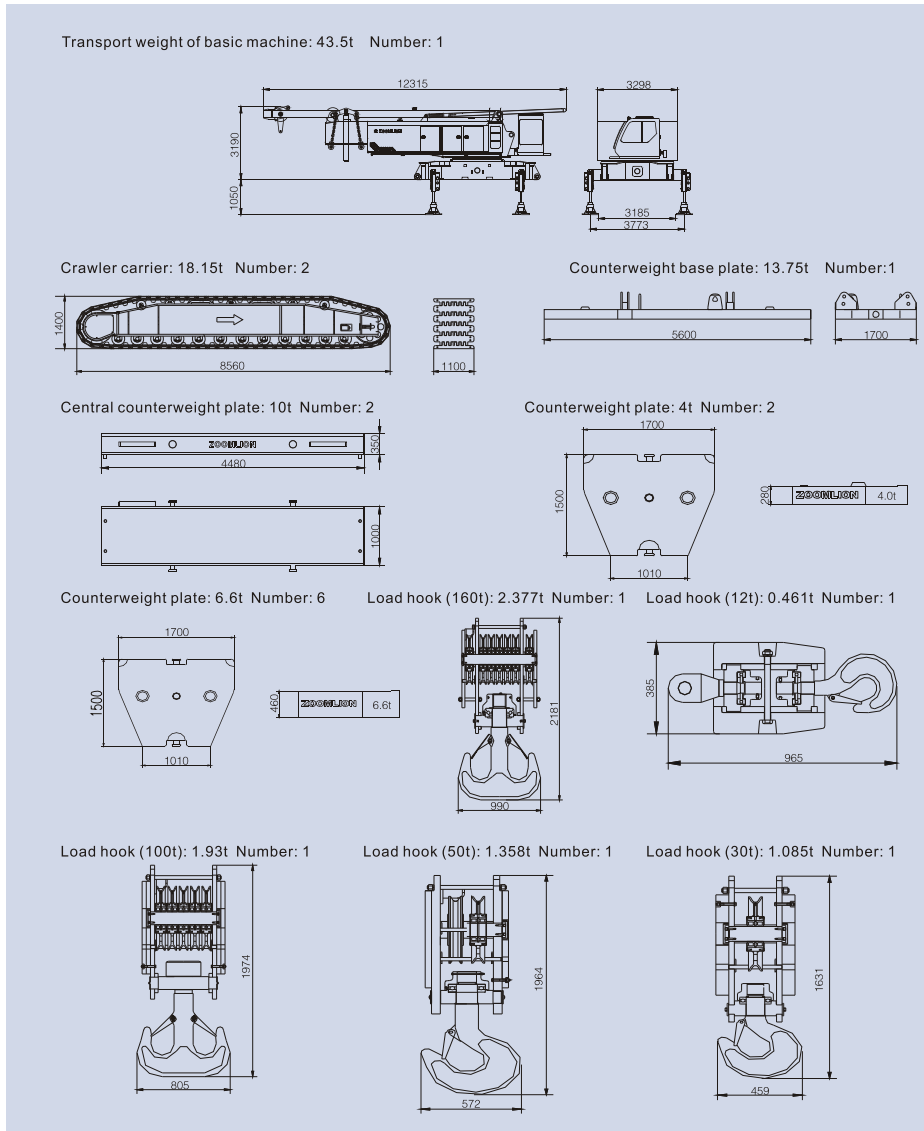

II. Technical instruction

4. Boom system

The lattice boom is made of imported high-strength steel pipes, and the anchoring rod is made of imported high-strength steel plate.

Main boom (S boom)

S- main boom: 20 ~ 83m

Main boom intermediate section: 3m, 6m and 9m

Number of main boom intermediate section for S boom

| Main boom length (m) | Number of main boom intermediate section | | |
|----------------------|--|----|----|
| | 3m | 6m | 9m |
| 20 | 0 | 0 | 0 |
| 23 | 1 | 0 | 0 |
| 26 | 2 | 0 | 0 |
| 29 | 1 | 1 | 0 |
| 32 | 2 | 1 | 0 |
| 35 | 1 | 2 | 0 |
| 38 | 1 | 1 | 1 |
| 41 | 2 | 1 | 1 |
| 44 | 1 | 2 | 1 |
| 47 | 1 | 1 | 2 |
| 50 | 2 | 1 | 2 |
| 53 | 1 | 2 | 2 |
| 56 | 1 | 1 | 3 |
| 59 | 2 | 1 | 3 |
| 62 | 1 | 2 | 3 |
| 65 | 1 | 1 | 4 |
| 68 | 2 | 1 | 4 |
| 71 | 1 | 2 | 4 |
| 74 | 1 | 1 | 5 |
| 77 | 2 | 1 | 5 |
| 80 | 1 | 2 | 5 |
| 83 | 1 | 1 | 6 |

Main boom with fixed jib (SF boom)

S- main boom: 47m~71m

F- fixed jib: 13 m ~31 m

Fixed jib intermediate section: 6m

Max. length of main boom with fixed jib: 71 + 31m

Number of fixed jib intermediate section for SF boom

| Fixed jib length(m) | Number of fixed jib intermediate section | |
|---------------------|--|--|
| | 6m | |
| 13 | 0 | |
| 19 | 1 | |
| 25 | 2 | |
| 31 | 3 | |

Main boom with luffing jib (SW boom)

S- main boom: 38m~56m

W- luffing jib: 24 m ~51 m

Luffing jib intermediate section: 3m, 6m, and 9m

Max. length of main boom with luffing jib: 56 + 51m

Number of luffing jib intermediate section for SW boom

| Luffing jib length(m) | Number of luffing jib intermediate section | | |
|-----------------------|--|----|----|
| | 3m | 6m | 9m |
| 24 | 0 | 1 | 0 |
| 27 | 1 | 1 | 0 |
| 30 | 2 | 1 | 0 |
| 33 | 1 | 2 | 0 |
| 36 | 1 | 1 | 1 |
| 39 | 2 | 1 | 1 |
| 42 | 1 | 2 | 1 |
| 45 | 1 | 1 | 2 |
| 48 | 2 | 1 | 2 |
| 51 | 1 | 2 | 2 |

5. Working mechanism

Hoisting winches

The crane is fitted with two hoisting winches: hoisting winch 1 and hoisting winch 2. Both of them are composed of concealed axial piston variable displacement motor, balance valve, reducer, normally closed brake as well as wire rope. And they can be controlled independently.

The hoisting rope is rotation resistant wire rope imported from Germany.

There are two kinds of hoisting speeds for hoisting winches, which can improve the working efficiency dramatically.

| | | |
|------------------|---|------------|
| Hoisting winch 1 | Rope diameter | 26mm |
| | Rope length | 380 m |
| | Single rope speed (on the 6 th rope layer) | 0~110m/min |
| Hoisting winch 2 | Single rope force | 132 kN |
| | Rope diameter | 26mm |
| | Rope length | 380 m |
| Hoisting winch 2 | Single rope speed (on the 6 th rope layer) | 0~110m/min |
| | Single rope force | 132 kN |

Derricking winch

The derricking winch is composed of hydraulic motor, balance valve, reducer and normally closed brake as well as wire rope. And it can be controlled independently.

The derricking rope is imported from Germany.

It is also equipped with a ratchet locking device to prevent the derricking winch from rotating during long time parking.

| | | |
|------------------|---|------------|
| Derricking winch | Rope diameter | 26mm |
| | Rope length | 220 m |
| | Single rope speed (on the 5 th rope layer) | 0~30 m/min |
| | Single rope force | 130kN |

Slewing mechanism

The slewing mechanism consists of hydraulic motor, gear reducer, slewing brake valve, brake and pinion gear as well as slewing ring. The superstructure can realize 360° continuous rotation via slewing ring which is driven by pinion gear.

The slewing mechanism has controllable free swing function which can reduce the impacts on the crane and ensure that the slewing motion can be initiated /stopped more stably.

3-row roller type, external-geared slewing ring and slewing reducer built in the crane, are of strong load-carrying capacity and high precision, which can ensure stable and accurate slewing motion.

Infinitely variable speed from 0 to 1.4 r/min

The slewing mechanism can be locked by two mechanical locking devices in the front of slewing table.

Traveling mechanism

The traveling mechanism is fitted with two hydraulic motors and two traveling reducers. The hydraulic motor, traveling reducer and balance valve are all imported. Using control levers, the traveling movements can be controlled, such as traveling straight ahead/backwards, turning with a crawler, differential steering, turning on spot, traveling with load. This kind of design enables crane to have high maneuverability.

Traveling speed: 0 ~ 1.2km/h

Gradeability: 30%

The tension degree of crawler can be adjusted by jack quickly and conveniently.

A-frame erecting mechanism

The A-frame erecting mechanism consists of A-frame, erection cylinder, auxiliary hydraulic system and so on. It is mainly used for the assembly, dismantling or conversion of the machine on the site. After the A-frame is erected over 90°, it can be used to connect anchoring rods on it and anchoring rods on main boom, assemble boom sections as well as install crawler carriers and counterweight.

Operator's cab movement-controlling mechanism

To reduce the transport width of the basic machine, the operator's cab can be swiveled out of the side working position to the centre of slewing table.

To broaden the field of vision of crane operator, the cab can tilt backwards for 20° via tilting cylinder when the load is lifted to a high position.

Counterweight and its fitting & removal mechanism

The counterweight fitting& removal mechanism is composed of counterweight base plate, counterweight plate, counterweight lifting cylinder, assembly chain and counterweight bolting cylinder. The counterweight can be fitted and removed by crane itself without the help of auxiliary crane, so the utilization rate of crane is increased and the risk of accident is decreased during fitting of counterweight.

Crawler carrier self-assembly/dismantling mechanism

The crawler carrier self-assembly/dismantling mechanism consists of folding brackets, support cylinders, support cylinder control valves, crawler carrier bolting cylinders and so on. Support cylinders, the main load bearing components of crane, are used for raising the basic machine during assembly/dismantling. The crawler carrier bolting cylinders are used to connect the crawler carrier to undercarriage center section. The crawler carrier can be assembled /dismantled by crane itself without help of auxiliary crane. Therefore, not only the working efficiency is improved, the labor intensity is reduced, but also the safe operation is guaranteed.

6. Crane system

Hydraulic system

The hydraulic system is composed of main pump, control valve, hydraulic motor, hydraulic oil tank, and oil cooler and so on.

International advanced pump-control technology is applied in the hydraulic system. Main hydraulic elements such as pump, motor and main control valve are imported. They are of high energy-saving, great reliability and long service life.

Main hydraulic pump: dual variable displacement piston pump with double gear pump, driven by engine

Auxiliary mechanism is supplied oil by gear pump.

Main control valve: electro-hydraulic proportional pilot valve

Main circuit control way: main pump + main changeover valve, controlled by two control levers.

Hydraulic oil tank: 1000L

Oil cooler: it is an aluminium cooler, and the cooler fan is driven by hydraulic motor.

Overflow valve

The overflow valve fitted in hydraulic system can restrain the pressure in the oil circuit from rising irregularly, thus protect such hydraulic elements as hydraulic oil pump and hydraulic motor against damage and prevent the hydraulic system from being overloaded.

Electrical system

24VDC, negative ground, two batteries of 195 AH each

The electrical system of machine includes power source, engine start, engine shutdown, indicator lights, warning device, illumination device, fan, wiper, horn, hoisting limiter, hydraulic oil cooling fan, digital display system, PLC controller, engine preheating device, safety equipment etc. which not only ensure safe operation of the crane, but also provide a good working environment. The crane adopts CAN bus control technology, which connects the engine, PLC controller and digital display efficiently, possessing fault detecting and self-diagnosis function.

Crane engine

Imported Cummins Electronic Fuel Injection engine

Rated power/ rotational speed: 227kW/2000r/min

Max. output torque/ rotational speed: 1505Nm/1400r/min

Exhaust emissions according to U.S.EPA Tier 3 and EU Stage 3

Fuel tank has a great capacity of 700L, which can ensure long time working of engine.

Digital display system

The 10.4-inch LCD, having Chinese and English language versions, can show various data collected by PLC controller such as engine speed, water temperature, engine oil pressure, pressure of hydraulic pump, pressure of main motor, crane inclination, wind speed and operating hours of engine and so on. In this way, it can monitor the working state of crane at any time. When abnormal conditions occur, the system will send out red or yellow warning signal.

7. Safety equipment

Load moment limiter

It is composed of digital LCD, CPU, signal converter, sensor and so on. When actual load moment reaches 90% of the maximum permissible load moment, the warning light will light up and the buzzer will sound. When actual load moment reaches the maximum permissible load moment, the warning signals will be sent out, and the dangerous movements will be switched off automatically so as to avoid accidents caused by overloading of crane, and thus ensure normal and safe crane operation.

The following data can be shown on the digital LCD:

Moment ratio Main boom angle Main boom length

Working radius Actual load

Maximum permissible lifting load

Maximum permissible lifting height

Wind speed at boom head

Hoisting limiter

Device to prevent any specified upper limitation of the load lifting attachment from being exceeded.

If the load hook comes into contact with hoisting limit switch weight during its upward movement, the hoisting limit switch is triggered, the buzzer sounds, and the crane movement "spool up winch" is switched off.

Angle indicator

It is fitted at the lower rear end of boom pivot section (i.e. on the right side of the operator's cab). The operator can clearly see the boom angle in the cab.

Derricking (luffing) limiter

Device, constituted by load moment limiter and limit switch, to prevent derricking (luffing) motions of the main boom and/or luffing jib beyond specified limits

Tilting back support for main boom

The spring-loaded tilting-back steel support, mounted on the main boom pivot section, is used to prevent the main boom from tilting backwards.

Crane inclinometer

An electronic inclinometer to indicate the "levelled position" of the crane

Safety catch

Device to protect the lifted load from jumping out from the hook

Ratchet locking device for derricking winch

Device to prevent the derricking winch from rotating during long time parking

Lowering limiter

Device to ensure that three windings of rope on the hoist drum are maintained at all times during operation

When there are only 3 windings of wire rope left on the drum, the lowering limit switch is triggered, the buzzer sounds, and the crane movement "reel off winch" is switched off.

Anemometer

An electronic device to indicate the actual wind speed to the crane operator

Emergency shut-down button

Allow all crane movements and electrical control system to be cut off quickly in a dangerous situation.

Tricolor warning light

The warning light, by showing red, yellow and green three colors, can indicate loading status synchronously. The green color means the load ratio is less than 90%, the yellow color means the load ratio is between 90% and 100%, and the red color means that the load ratio has exceeded 100% and the crane is overloaded.

Monitoring system (optional)

2 video cameras: respectively monitor the working condition of crane winches and rear side of the crane
Display: switch between the monitoring screens via press-key.

Remote monitoring system GPS (optional)

Application of GPS enables such functions to be available as global positioning, GPRS data transmitting, working condition monitoring, remote fault diagnosing.

8. Operator's cab

Spacious, comfortable and all-steel construction cab, equipped with sun visor, adjustable seat, wiper, electric control levers, display of load moment limiter, digital display system, switches on auxiliary control box, air conditioning, fan, lighting lamp, CD player (and/or DVD player), cigarette lighter, fire extinguisher etc. The cab can be tiltable backwards from 0 ~ 20° during operation to broaden the field of vision of crane operator.

9. Load Hook

160t load hook: 7 pulleys

100t load hook: 4 pulleys

50t load hook: 2 pulleys

30t load hook: 1 pulley

12t load hook: without pulley

III. Self-assembly & dismantling function

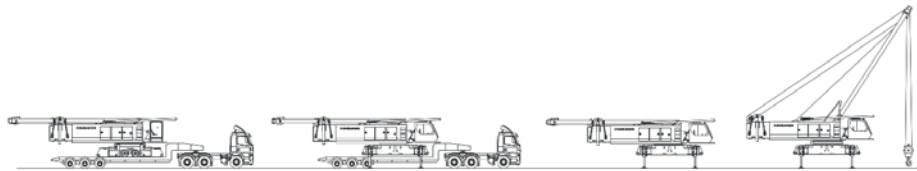

Unloading of basic machine

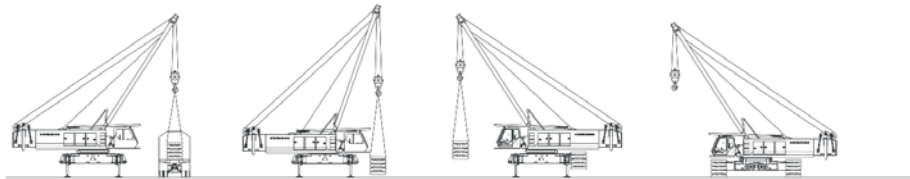

Unloading and assembly of crawler carriers

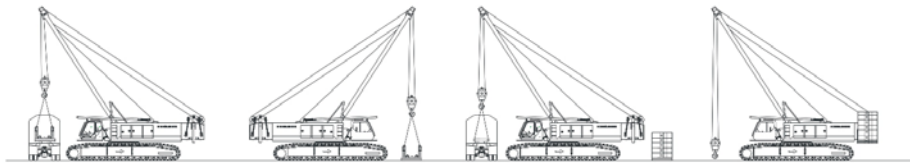

Unloading and assembly of rear counterweight

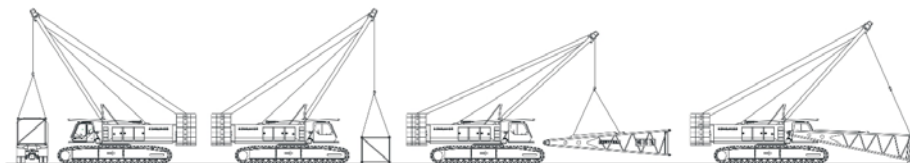

Unloading of boom frame

Assembly of boom frame and anchoring rods

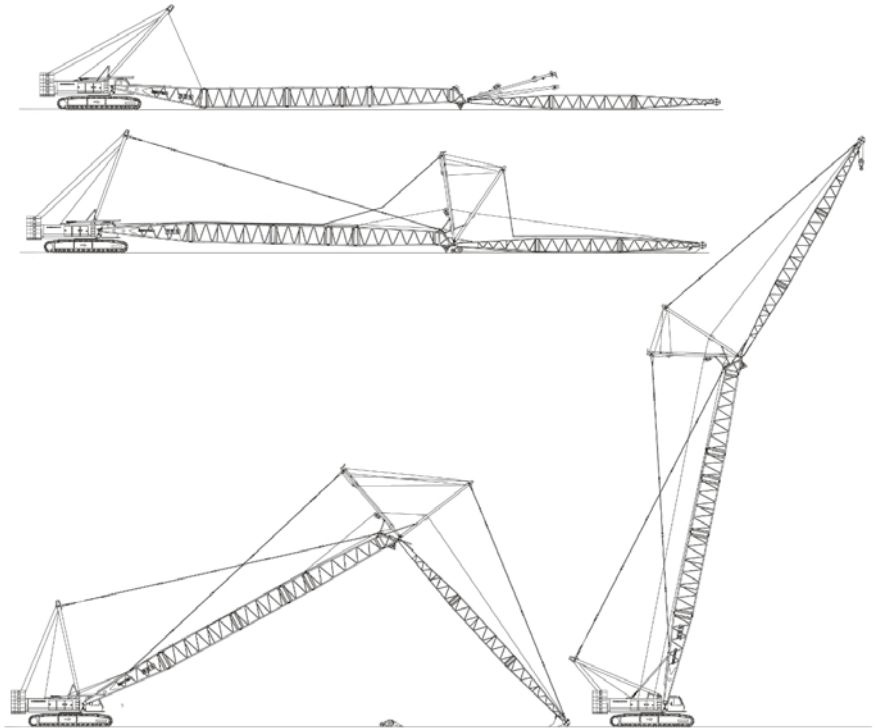

Boom in working position

IV. Lifting capacity

10. Lifting performance on S boom

Lifting height on S boom

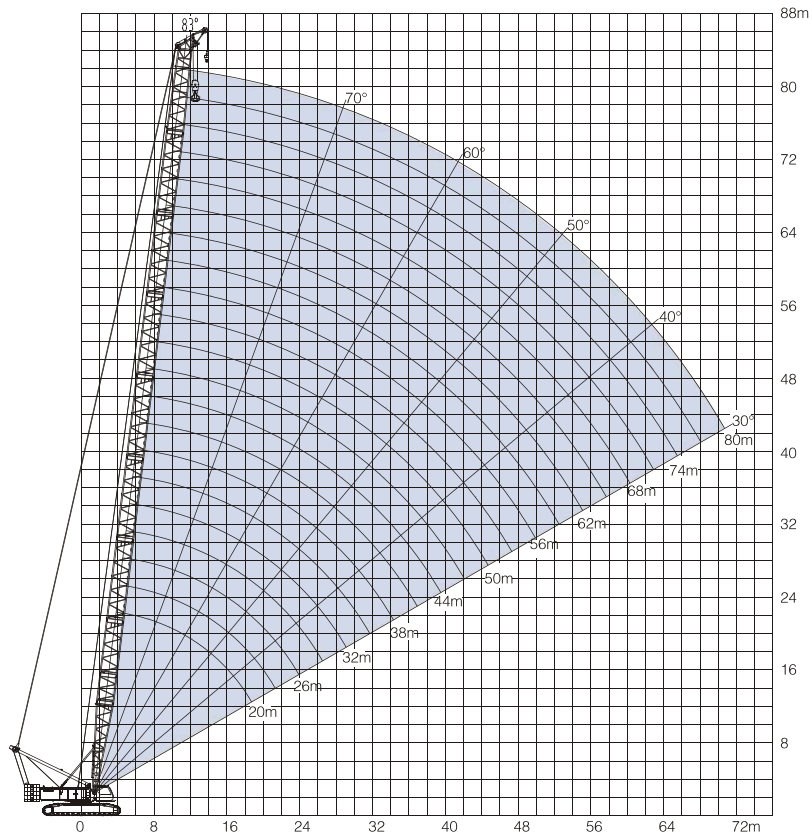

Lifting capacity on S boom (1)

| Radius (m) \ Length of S (m) | 20 | 23 | 26 | 29 | 32 | 35 | 38 | 41 | 44 | 47 | 50 |
|------------------------------|------|-------|------|------|------|------|------|------|------|------|------|
| 5 | 160 | | | | | | | | | | |
| 6 | 148 | 140 | 130 | | | | | | | | |
| 7 | 129 | 123 | 115 | 110 | 105 | | | | | | |
| 8 | 105 | 102.5 | 99 | 95 | 92 | 90 | 85 | | | | |
| 9 | 90 | 88 | 85 | 84 | 83 | 80 | 77.2 | 72 | | | |
| 10 | 80 | 76.5 | 75 | 73 | 72 | 71.6 | 70 | 66 | 63 | 62 | |
| 12 | 62 | 59.5 | 59.5 | 59.2 | 58 | 57.4 | 57.2 | 57 | 56.5 | 54 | 51 |
| 14 | 50.5 | 50.3 | 50.2 | 50.2 | 50.1 | 50 | 50 | 50 | 49.8 | 48.9 | 44.5 |
| 16 | 42.8 | 42.8 | 42.5 | 42.5 | 42.2 | 42.2 | 42.2 | 42.2 | 42 | 41.8 | 41.5 |
| 18 | | 37.3 | 37.2 | 37.2 | 37.2 | 36.8 | 36.8 | 36.8 | 36.6 | 36.5 | 35.8 |
| 20 | | 32.8 | 32.8 | 32.5 | 32.5 | 32 | 32 | 31.9 | 31.7 | 31.7 | 31.5 |
| 22 | | | 28 | 27.5 | 27.5 | 27.3 | 27.3 | 27.2 | 27.2 | 27.1 | 26.9 |
| 24 | | | 25 | 25 | 24.8 | 24.8 | 24.5 | 24.3 | 24.3 | 24.1 | 23.7 |
| 26 | | | | 22.5 | 22.2 | 22 | 22 | 21.9 | 21.7 | 21.7 | 21.3 |
| 28 | | | | | 20 | 20 | 19.7 | 19.5 | 19.5 | 19.3 | 19.1 |
| 30 | | | | | | 18.2 | 18 | 17.8 | 17.8 | 17.7 | 17.5 |
| 32 | | | | | | 16.3 | 16.2 | 16.2 | 16.2 | 16 | 15.8 |
| 34 | | | | | | | 15 | 15 | 14.9 | 14.6 | 14.3 |
| 36 | | | | | | | | 14.1 | 13.9 | 13.8 | 13.3 |
| 38 | | | | | | | | | 13.2 | 12.7 | 12.4 |
| 40 | | | | | | | | | | 11.5 | 11.3 |
| 42 | | | | | | | | | | | 10.6 |
| 44 | | | | | | | | | | | 9.8 |

11. Lifting performance on SF boom

Lifting capacity on S boom (2)

| Length of S(m) Radius (m) | 53 | 56 | 59 | 62 | 65 | 68 | 71 | 74 | 77 | 80 | 83 |
|------------------------------|------|------|------|------|------|------|------|------|------|------|------|
| 12 | 49 | 48 | 47 | | | | | | | | |
| 14 | 43.5 | 42 | 40.8 | 40 | 38 | 36.5 | 33 | | | | |
| 16 | 39.5 | 37 | 35.5 | 35.5 | 34 | 33.5 | 31.7 | 30.5 | 28 | 24.6 | 22 |
| 18 | 35.6 | 34.5 | 31.5 | 31.4 | 31.3 | 31.1 | 29.4 | 28 | 26.2 | 23.5 | 21 |
| 20 | 31.3 | 31 | 29.8 | 27.2 | 27.1 | 27 | 26.5 | 25.5 | 24.5 | 22 | 20 |
| 22 | 26.9 | 26.7 | 26.5 | 25.6 | 23.8 | 23.5 | 23.3 | 23.1 | 22.7 | 21 | 19 |
| 24 | 23.5 | 23.2 | 22.8 | 22.6 | 21 | 20.8 | 20.6 | 20.5 | 20.2 | 20 | 18 |
| 26 | 21 | 20.8 | 20.4 | 20.3 | 19 | 19 | 18.6 | 18.2 | 17.8 | 17.8 | 17 |
| 28 | 18.9 | 18.8 | 18.2 | 18.1 | 17.3 | 17.3 | 16.8 | 16.6 | 16 | 15.8 | 15.6 |
| 30 | 17.2 | 17 | 16.5 | 16.5 | 16 | 15.8 | 15.2 | 15.2 | 15.1 | 15.1 | 14.2 |
| 32 | 15.5 | 15.5 | 15 | 15 | 14.8 | 14.5 | 14 | 13.9 | 13.6 | 13.5 | 12.5 |
| 34 | 14 | 13.9 | 13.8 | 13.8 | 13.5 | 13.5 | 12.8 | 12.8 | 12.6 | 12.1 | 11.5 |
| 36 | 13 | 12.8 | 12.6 | 12.5 | 12.2 | 12.2 | 11.8 | 11.8 | 11.2 | 11.1 | 10.8 |
| 38 | 11.9 | 11.8 | 11.6 | 11.5 | 11.2 | 11.1 | 10.9 | 10.9 | 10.2 | 10.1 | 9.8 |
| 40 | 11 | 10.8 | 10.5 | 10.5 | 10.2 | 10.2 | 10 | 10 | 9.5 | 9.3 | 9.0 |
| 42 | 10.2 | 10 | 9.8 | 9.7 | 9.5 | 9.4 | 9.1 | 9.1 | 8.7 | 8.6 | 8.2 |
| 44 | 9.5 | 9.3 | 9.1 | 9.0 | 8.6 | 8.5 | 8.3 | 8.2 | 8.0 | 7.5 | 7.3 |
| 46 | 8.6 | 8.5 | 8.3 | 8.3 | 8.0 | 8.0 | 7.7 | 7.2 | 7.2 | 7.0 | 6.8 |
| 48 | | 8 | 7.6 | 7.6 | 7.3 | 7.3 | 7.0 | 7.0 | 6.7 | 6.3 | 6.2 |
| 50 | | | 7 | 7 | 6.8 | 6.8 | 6.5 | 6.0 | 6.0 | 5.8 | 5.8 |
| 55 | | | | 6.1 | 6.0 | 5.6 | 5.4 | 5.2 | 5.0 | 4.8 | 4.6 |
| 60 | | | | | 4.7 | 4.2 | 4.2 | 3.9 | 3.8 | 3.4 | |
| 65 | | | | | | 3.5 | 3.3 | 3.1 | 3.0 | 2.7 | |
| 70 | | | | | | | | | 2.2 | 2.1 | |

Lifting height on SF boom

